

CITY OF SACRAMENTO

Permit No: 9901179

1231 I Street, Sacramento, CA 95814

Insp Area: 1

Site Address: 944 44TH ST SAC

Sub-Type: ASFR

Parcel No: 008-0092-009

Housing (Y/N): N

CONTRACTOR

OWNER

ARCHITECT

MATHAI MATHEW/NANCY
944 44TH ST
SACRAMENTO CA 95819

WHITELAM & WHITELAM
2102 19TH ST
SACRAMENTO CA 95818

Nature of Work: 621 SQ FT 2ND STORY ADDITION&REMODEL KITCHEN,HALL&BATH

CONSTRUCTION LENDING AGENCY: I hereby affirm under penalty of perjury that there is a construction lending agency for the performance of the work for which this permit is issued (Sec. 3097, Civ. C).

Lender's Name Lender's Address

LICENSED CONTRACTORS DECLARATION: I hereby affirm under penalty of perjury that I am licensed under provisions of Chapter 9 (commencing with section 7000) of Division 3 of the Business and Professions Code and my license is in full force and effect.

License Class License Number Date Contractor Signature

OWNER-BUILDER DECLARATION: I hereby affirm under penalty of perjury that I am exempt from the contractors License Law for the following reason (Sec. 7031.5, Business and Professions Code; any city or county which requires a permit to construct, alter, improve, demolish, or repair any structure, prior to its issuance, also requires the applicant for such permit to file a signed statement that he or she is licensed pursuant to the provisions of the Contractors License Law (Chapter 9 (commencing with Section 7000) of Division 8 of the Business and Professions Code) or that he or she is exempt therefrom and the basis for the alleged exemption. Any violation of Section 7031.5 by any applicant for a permit subjects the applicant to a civil penalty of not more than five hundred dollars (\$500.00);

I, as a owner of the property, or my employees with wages as their sole compensation, will do the work, and the structure is not intended or offered for sale (Sec. 7044, Business and Professional Code: The Contractors License Law does not apply to an owner of property who builds or improves thereon, and who does such work himself or herself or through his/her own employees, provided that such improvements are not intended or offered for sale. If, however, the building or improvement is sold within one year of completion, the owner-builder will have the burden of proving that he/she did not build or improve for the purpose of sale.)

I, as owner of the property, am exclusively contracting with licensed contractors to construct the project (Sec. 7044, Business and Professions Code) The Contractors License Law does not apply to an owner of property who builds or improves thereon, and who contracts for such projects with a contractor(s) licensed pursuant to the Contractors License Law.

I am exempt under Sec. B & PC for this reason:

Date 3/22/99 Owner Signature Mathew Mathew

IN ISSUING THIS BUILDING PERMIT, the applicant represents, and the city relies on the representation of the applicant that the applicant verified all measurements and locations shown on the application or accompanying drawings and that the improvements to be constructed do not violate any law or private agreement relating to permissible or prohibited locations for such improvements. This building permit does not authorize any illegal location of any improvement or the violation of any private agreement relating to location of improvements.

I certify that I have read this application and state that all information is correct. I agree to comply with all city and county ordinances and state laws relating to building construction and hereby authorize representative(s) of this city to enter upon the abovementioned property for inspection purposes.

Date 3/22/99 Applicant/Agent Signature Mathew Mathew

WORKER'S COMPENSATION DECLARATION: I hereby affirm under penalty of perjury one of the following declarations:

I have and will maintain a certificate of consent to self-insure for workers' compensation as provided for by Section 3700 of the Labor Code, for the performance of work for which the permit is issued.

I have and will maintain workers' compensation insurance, as required by Section 3700 of the Labor Code, for the performance of the work for which this permit is issued. My workers' compensation insurance carrier and policy number are:

Carrier N/A Policy Number Exp Date

(This section need not be completed if the permit is for \$100 or less) I certify that in the performance of the work for which this permit is issued, I shall not employ any person in any manner so as to become subject to the workers' compensation laws of California and agree that if I should become subject to the workers' compensation provisions of Section 3700 of the Labor Code, I shall forthwith comply with those provisions.

Date 3/22/99 Applicant Signature Mathew Mathew

WARNING: FAILURE TO SECURE WORKER'S COMPENSATION COVERAGE IS UNLAWFUL AND SHALL SUBJECT AN EMPLOYER TO CRIMINAL PENALTIES AND CIVIL FINES UP TO ONE HUNDRED THOUSAND DOLLARS (\$100,000) IN ADDITION TO THE COST OF COMPENSATION. DAMAGES AS PROVIDED FOR IN SECTION 3706 OF THE LABOR CODE, INTEREST AND ATTORNEY'S FEE.

THIS PERMIT SHALL EXPIRE BY LIMITATION IF WORK IS NOT COMMENCED WITHIN 180 DAYS.

CERTIFICATION OF COMPLIANCE

SCHOOL DISTRICT DEVELOPMENT FEES

(Print or Type)

225 Ave  
209 4231

PART I TO BE COMPLETED BY APPLICANT

PROPERTY OWNER'S NAME 944-44th St  
OWNER ADDRESS  
PROJECT ADDRESS 944-44th St  
LOT NO.  
SECTION NAME  
NUMBER OF UNITS  
APPLICANT'S SIGNATURE  
APPLICANT  
TELEPHONE NUMBER

PART II TO BE COMPLETED BY BUILDING DEPARTMENT

CERTIFICATION NO.  
BUILDING TYPE CHECK ONE  
RESIDENTIAL ( ) APARTMENT/CONDOMINIUM ( ) COMMERCIAL/INDUSTRIAL ( )  
SQUARE FEET OF (HABITABLE) BUILDING AREA  
SIGNATURE  
DATE 3/2/99

PART III TO BE COMPLETED BY SCHOOL DISTRICT

SCHOOL DISTRICT  
CERTIFICATION NO.  
FEES COLLECTED  
RESIDENTIAL 621 SQ. FT X \$ 1.72 = \$ 1068.12  
APARTMENT/CONDOMINIUM SQ. FT X \$ = \$  
COMMERCIAL/INDUSTRIAL SQ. FT X \$ = \$

This certification covers only the amount of square footage indicated above. Any additions or corrections to the square footage for this project will require an amendment to the Certificate of Compliance.

As the authorized school district official, I hereby certify that the requirements of Government Code Section 65995 have been complied with by the above named applicant.

AUTHORIZED SCHOOL DISTRICT OFFICIAL  
SIGNATURE  
DATE 3/2/99

City of San Diego  
School District  
Building Department  
Applicant

OWNER-BUILDER VERIFICATION  
ATTENTION PROPERTY OWNER

An owner-builder building permit has been applied for in your name and bearing your signature.

Please complete and return this information in the envelope provided at your earliest opportunity to avoid unnecessary delay in processing and issuing your building permit. No building permit will be issued until this verification is received.

1. I personally plan to provide the major labor and materials for construction of the proposed improvement (yes or no) \_\_\_\_\_

2. I have have not \_\_\_\_\_ signed an application for a building permit for the proposed work.

3. I have contracted with the following person (firm) to provide the proposed construction:

Name \_\_\_\_\_ Address \_\_\_\_\_  
City \_\_\_\_\_ Telephone 484-3422  
Contractors License No. \_\_\_\_\_

4. I plan to provide portions of the work, but I have hired the following person to coordinate, supervise and provide the major work.

Name \_\_\_\_\_ Address \_\_\_\_\_  
City \_\_\_\_\_ Telephone \_\_\_\_\_  
Contractors License No. \_\_\_\_\_

5. I will provide some of the work but I have contracted (hired) the following to provide the work indicated:

Name	Address	Phone	Type of Work

Signed \_\_\_\_\_

Job Address \_\_\_\_\_

Date 3/3/99

Permit No. 9901179

JOB MATHAI HOUSE

CLIENT Whitelam

JOB NO.

DESIGNED BY ER

DATE 4/5/99 PAGE 1

(E) FOUNDATION CHECK

$$P = [(40 + 10)(18/2) + 4(3)](20/13) + 66(18/2) / 1.33 = 678 \# /$$

$$Q_{allow} = 678 + 14(8) + (40 + 10)(4) = 990 \# /$$

$$\Delta = 990(1') / 1000 \text{ psf} = .990 \text{ ft}^2$$

12" cont. flg. ok

AT HOLDOWNS

$$P = 3480 \#$$

$$L_r = 3480 / 1000 \text{ psf} = 3.48$$

10' -

$$Q = 20 \left[ \frac{(0.5)^2 + 10(3)^2 + 7(2)}{144} \right] (20) = 4021 \# \text{ ok}$$

USE 2'-0" # x 12" dep.

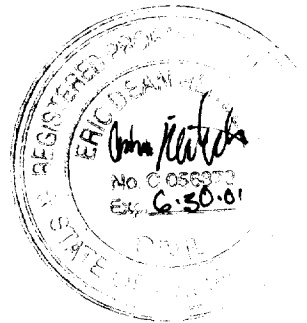

JOB MATHAI HOUSE

CLIENT Whitlam

JOB NO.

DESIGNED BY ER

DATE 4/5/99 PAGE

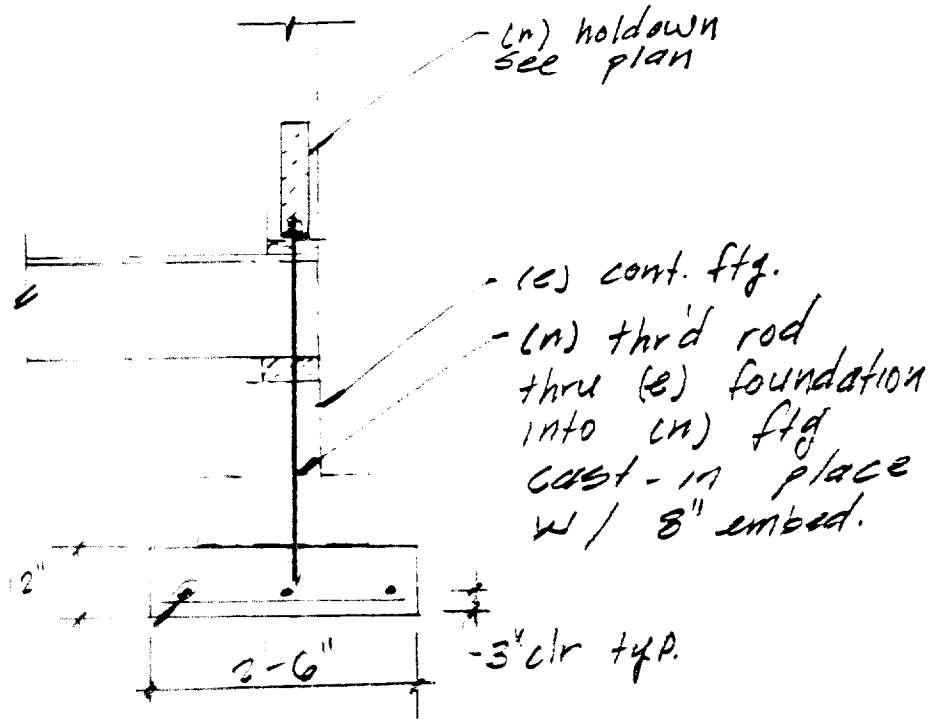

3-#4  
sa way

NO SCALE

