

CITY OF SACRAMENTO

Permit No: 0605588

1231 I Street, Sacramento, CA 95814

Insp Area: 4

Thos Bros: 256J4

PAID

CITY OF SACRAMENTO

Sub-Type: REM

Housing (Y/N): N
APR 24 2006

Site Address: 2935 MACON DR SAC

Parcel No: 201-0630-065

CONTRACTOR

OWNER

MOORE TODD J/CHRISTI M
2935 MACON WAY
SACRAMENTO, CA 95835

ARCHITECT

NEIGHBORHOODS PLANNING
AND DEVELOPMENT SERVICES

Nature of Work: RELOCATE POWER SUPPLY METER 3-4' FOR DEVELOPER ACCESS - METER LOCATED IN PUB

CONSTRUCTION LENDING AGENCY : I hereby affirm under penalty of perjury that there is a construction lending agency for the performance of the work for which this permit is issued (Sec. 3097, Civ. C).

Lender's Name _____ Lender's Address _____

LICENSED CONTRACTORS DECLARATION: I hereby affirm under penalty of perjury that I am licensed under provisions of Chapter 9 (commencing with section 7000) of Division 3 of the Business and Professions Code and my license is in full force and effect.

License Class _____ License Number _____ Date _____ Contractor Signature _____

OWNER-BUILDER DECLARATION: I hereby affirm under penalty of perjury that I am exempt from the contractors License Law for the following reason (Sec. 7031.5, Business and Professions Code; any city or county which requires a permit to construct, alter, improve, demolish, or repair any structure, prior to its issuance, also requires the applicant for such permit to file a signed statement that he or she is licensed pursuant to the provisions of the Contractors License Law (Chapter 9 (commencing with Section 7000) of Division 8 of the Business and Professions Code) or that he or she is exempt therefrom and the basis for the alleged exemption. Any violation of Section 7031.5 by any applicant for a permit subjects the applicant to a civil penalty of not more than five hundred dollars (\$500.00);

I, as a owner of the property, or my employees with wages as their sole compensation, will do the work, and the structure is not intended or offered for sale (Sec. 7044, Business and Professional Code: The Contractors License Law does not apply to an owner of property who builds or improves thereon, and who does such work himself or herself or through his/her own employees, provided that such improvements are not intended or offered for sale. If, however, the building or improvement is sold within one year of completion, the owner-builder will have the burden of proving that he/she did not build or improve for the purpose of sale.)

I, as owner of the property, am exclusively contracting with licensed contractors to construct the project (Sec. 7044, Business and Professions Code: The Contractors License Law does not apply to an owner of property who builds or improves thereon, and who contracts for such projects with a contractor(s) licensed pursuant to the Contractors License Law).

I am exempt under Sec. _____ B & PC for this reason: _____

X Date 4/24/06 Owner Signature AA OPERATIONS MANAGER

IN ISSUING THIS BUILDING PERMIT, the applicant represents, and the city relies on the representation of the applicant, that the applicant verified all measurements and locations shown on the application or accompanying drawings and that the improvement to be constructed does not violate any law or private agreement relating to permissible or prohibited locations for such improvements. This building permit does not authorize any illegal location of any improvement or the violation of any private agreement relating to location of improvements.

I certify that I have read this application and state that all information is correct. I agree to comply with all city and county ordinances and state laws relating to building construction and hereby authorize representative(s) of this city to enter upon the abovementioned property for inspection purposes.

X Date 4/24/06 Applicant/Agent Signature AA OPERATIONS MANAGER

WORKER'S COMPENSATION DECLARATION: I hereby affirm under penalty of perjury one of the following declarations:

I have and will maintain a certificate of consent to self-insure for workers' compensation as provided for by Section 3700 of the Labor Code, for the performance of work for which the permit is issued.

I have and will maintain workers' compensation insurance, as required by Section 3700 of the Labor Code, for the performance of the work for which this permit is issued. My workers' compensation insurance carrier and policy number are:

Carrier _____ Policy Number _____ Exp Date _____

X WF (This section need not be completed if the permit is for \$100 or less) I certify that in the performance of the work for which this permit is issued, I shall not employ any person in any manner so as to become subject to the workers' compensation laws of California and agree that if I should become subject to the workers' compensation provisions of Section 3700 of the Labor Code, I shall forthwith comply with those provisions.

X Date 4/24/06 Applicant Signature AA OPERATIONS MANAGER

WARNING: FAILURE TO SECURE WORKER'S COMPENSATION COVERAGE IS UNLAWFUL AND SHALL SUBJECT AN EMPLOYER TO CRIMINAL PENALTIES AND CIVIL FINES UP TO ONE HUNDRED THOUSAND DOLLARS (\$100,000) IN ADDITION TO THE COST OF COMPENSATION, DAMAGES AS PROVIDED FOR IN SECTION 3706 OF THE LABOR CODE, INTEREST AND ATTORNEY'S FEE.

THIS PERMIT SHALL EXPIRE BY LIMITATION IF WORK IS NOT COMMENCED WITHIN 180 DAYS.

APPLICATION FOR COMMERCIAL BUILDING PERMIT

CITY OF SACRAMENTO
PLANNING & BUILDING DIVISION
PERMIT SERVICES SECTION
 (916) 808-2534 FAX: (916) 808-7046

ACTIVITY # 0605588	Insp. Area
---	-------------------

Applicant **MUST** complete ALL Unshaded Areas

ADDRESS: 2935 MACON Suite: _____

PARCEL #: _____

<p style="text-align: center;">CONTACT</p> <p>Name: William Ford Street Address: 4229 Northgate Blvd. 7 City/State/Zip: Sacramento, Co Phone: (916) 641-5990 E-Mail: Will@SAC.STICARE.COM</p>	<p style="text-align: center;">LICENSED CONTRACTOR Lic No. # _____</p> <p>Name: _____ Street Address: _____ City/State/Zip: _____ Phone: _____ E-Mail: _____</p>
<p style="text-align: center;">ARCHITECT/ENGINEER</p> <p>Name: _____ Street Address: _____ City/State/Zip: _____ Phone: _____ E-Mail: _____</p>	<p style="text-align: center;">OWNER</p> <p>Name: STRATEGIC TECHNOLOGIES INC Street Address: 4229 Northgate Blvd. 7 City/State/Zip: Sacramento, Co 95834 Phone: _____ E-Mail: _____</p>

⇒ Will permittee have any employees on the jobsite? No Yes ⇒ Insurance Co.: _____

⇒ WORKER'S COMPANSATION POLICY # _____ EXPIRATION DATE: _____

NATURE OF WORK IN DETAIL: To Relocate Power Supply (Back up) Meter
3-4' for developer Access in Notomas Park

OCCUPANT/TENANT: _____ **VALUATION:** 975.00

FLOOD STATUS:			S.C.A.T.							
JOB DESCRIPTION	BLDG	SHELL	APT	TI ()	REM ()	SW	FIRE	ADD	OTH	
INSPECTION DISCIPLINES			BLDG	MECH	PLUMB	ELEC		SITE	FIRE	
# Stories	1 st Flr Area	Total Area	Use Zone	Occp Group	Const type	Fire Req. Y / N		Fed Code	Vio. [H]	File [Quad]
B	L	P	M	E	F	SPR	ALARM	D	PW	UTIL

COMMENTS:

REGIONAL SANITATION FEES? Yes No **HEALTH DEPARTMENT:** Yes No

WATER FLOW TEST FOR NEW BUILDINGS OR ADDITIONS? Provided Faxed

0605588

APPROVED PER 2002
NATIONAL ELECTRICAL CODE
CITY OF SACRAMENTO
AMENDMENTS
4-24-06
ELECTRICAL DIVISION

ISSUED
City of Sacramento

APR 24 2006

NORTH PERMIT
CENTER

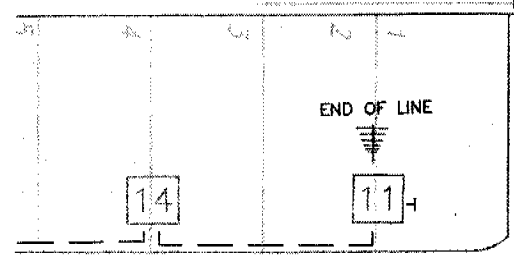

KALAMER WY

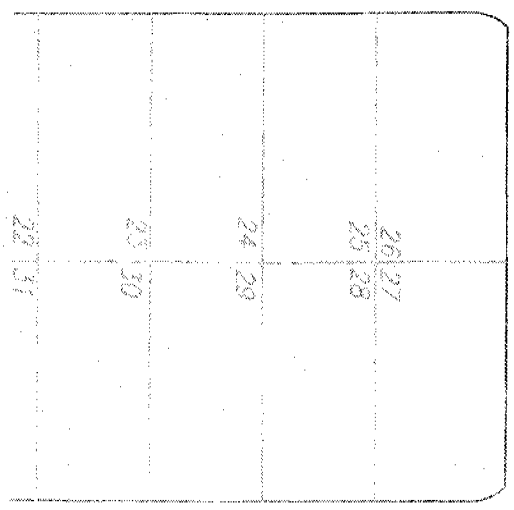

LAWLER ST

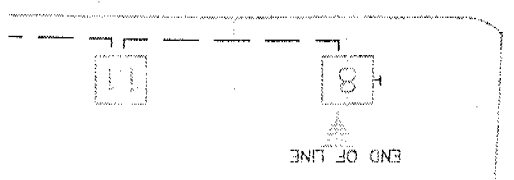

CITY COPY

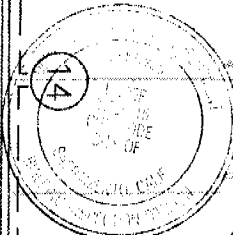
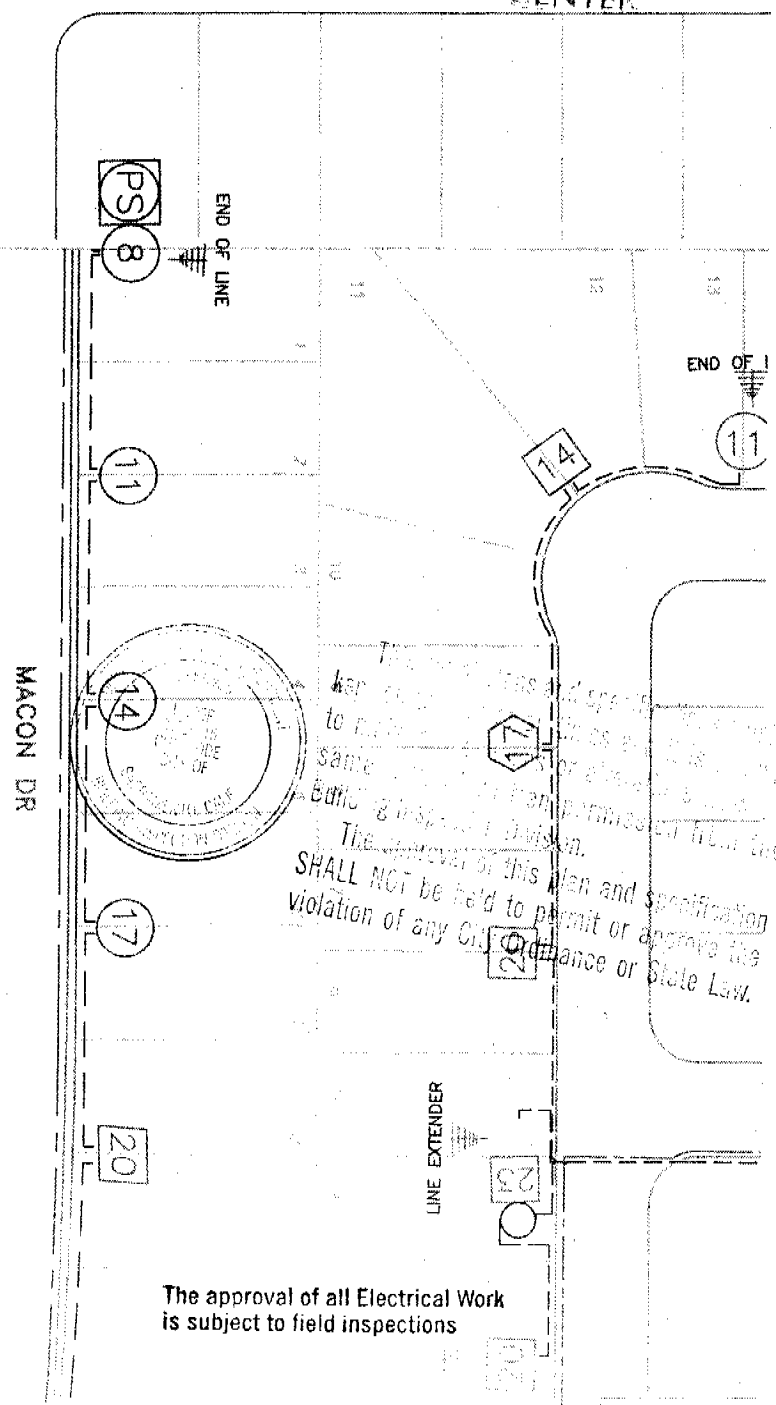

The approval of this plan and specification
SHALL NOT be held to permit or approve the
violation of any City Ordinance or State Law.

The approval of all Electrical Work
is subject to field inspections

LECTRO®

by Alpha



ISSUED
City of Sacramento

APR 24 2006

**NORTH PERMIT
CENTER**

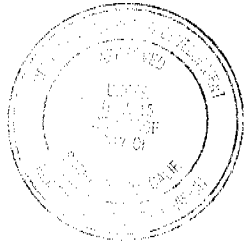

This set of plans and specifications shall be kept on the job at all times and it is prohibited to make any changes or alterations to the same without written permission of the Building Inspection Division.

The approval of this plan and specification SHALL NOT be taken to permit or authorize violation of any applicable laws or regulations.

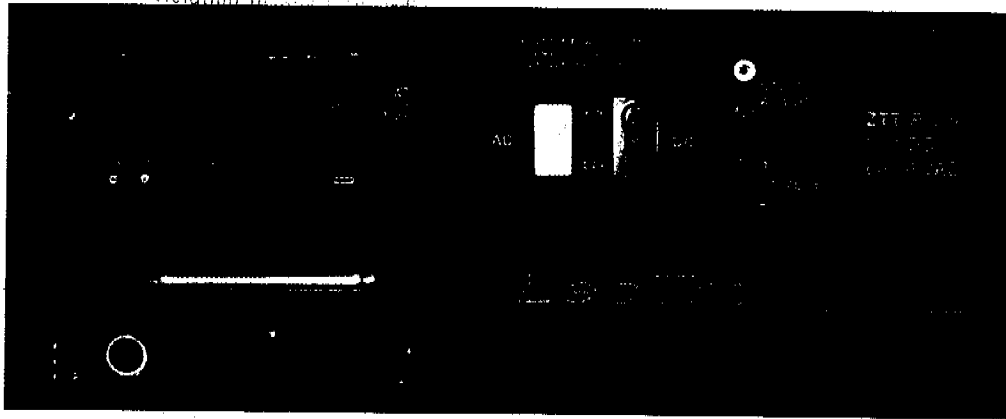

The approval of all Electrical Work is subject to field inspections

ZTT/Plus CATV UPS Users Guide

120V Input Model

Effective: June, 2003



2. Cabinet Installation

2.2 Ground-Mount Cabinet, *continued*

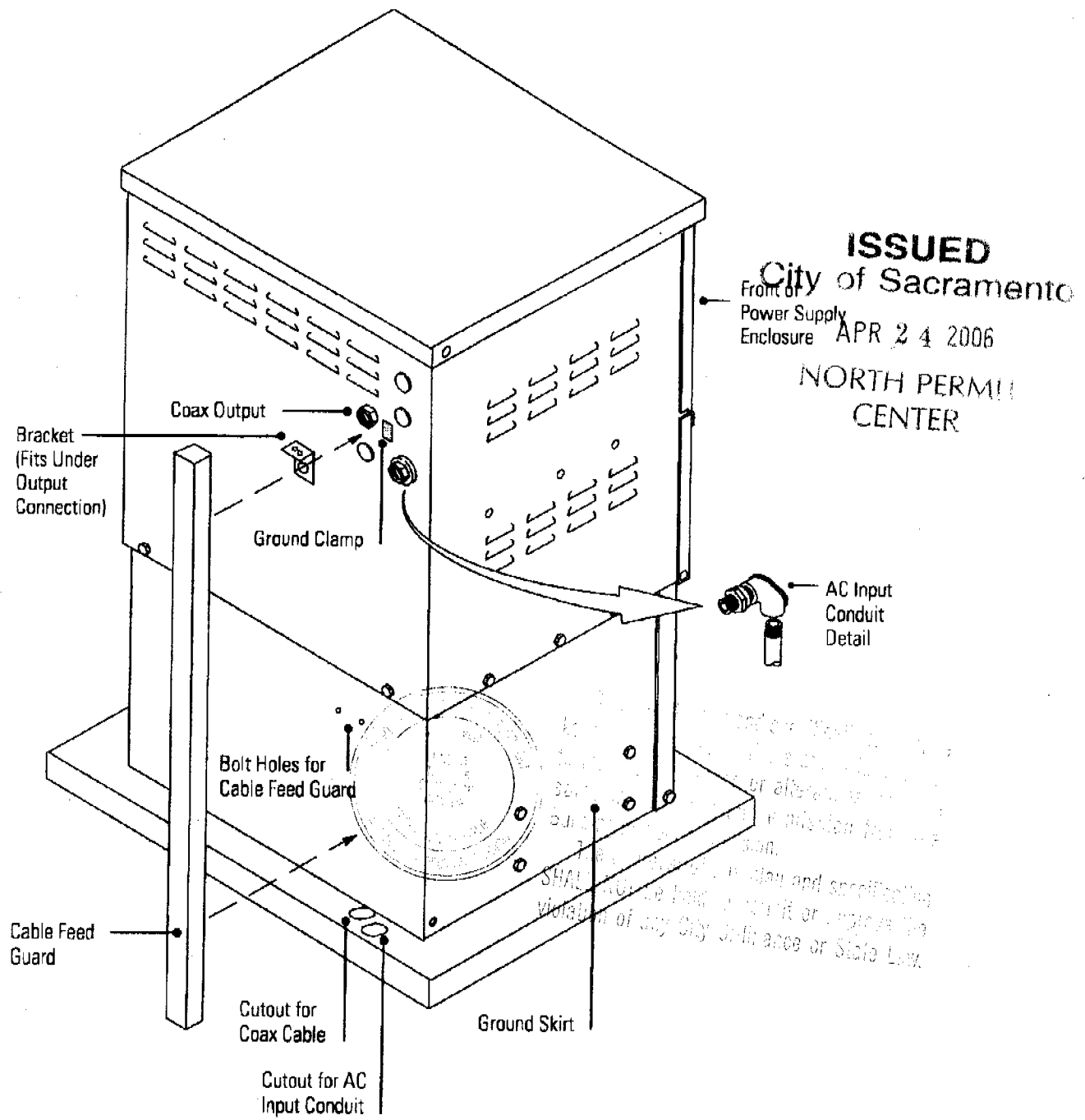
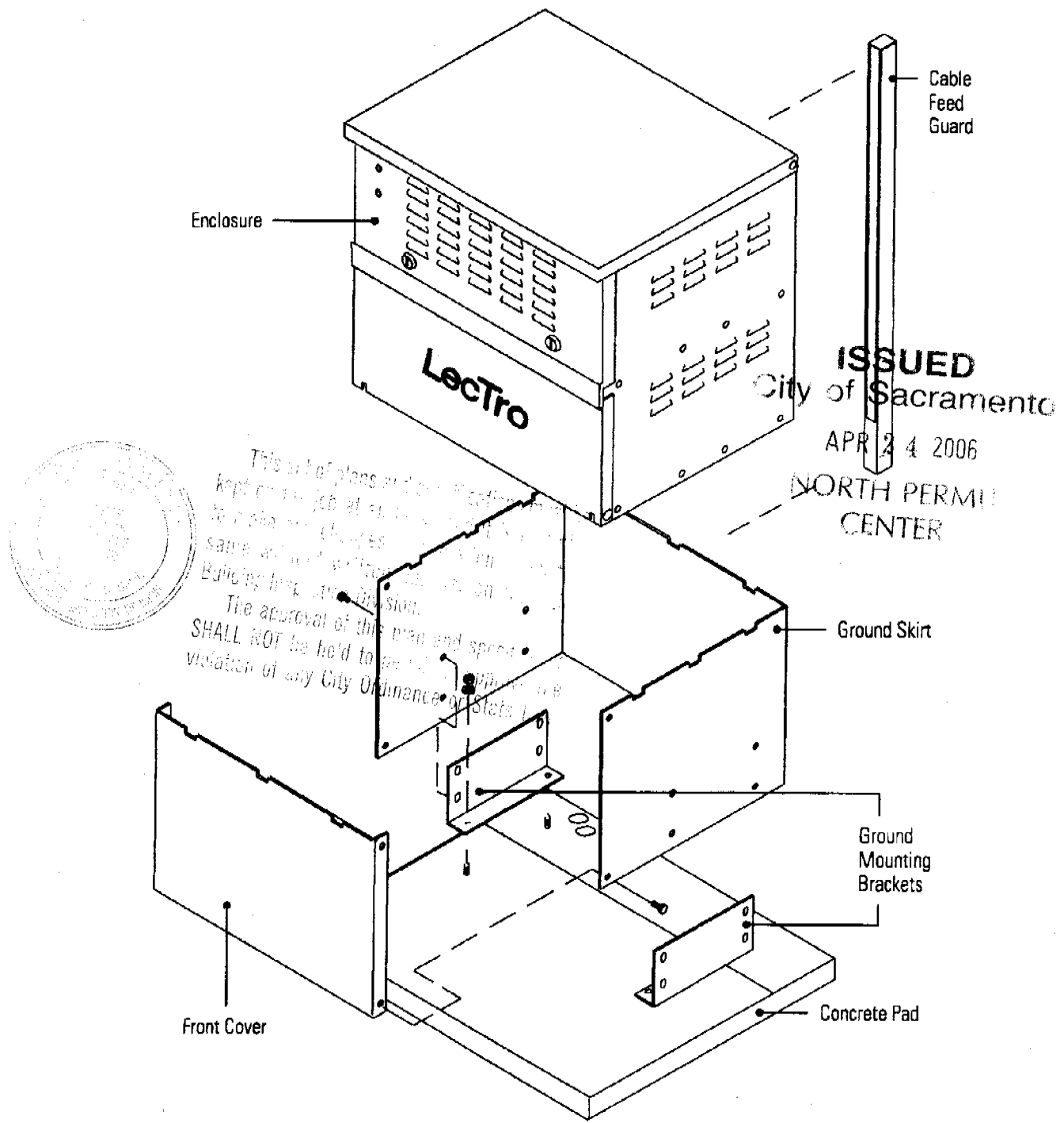

Fig. 2-7 Ground Mount (Rear View)

The approval of all Electrical Work is subject to field inspections

2.2 Ground-Mount Cabinet, *continued*



The approval of all Electrical Work is subject to field inspections

Fig. 2-6 Ground Mount (Front View)

2. Cabinet Installation

2.2 Ground-Mount Cabinet, *continued*

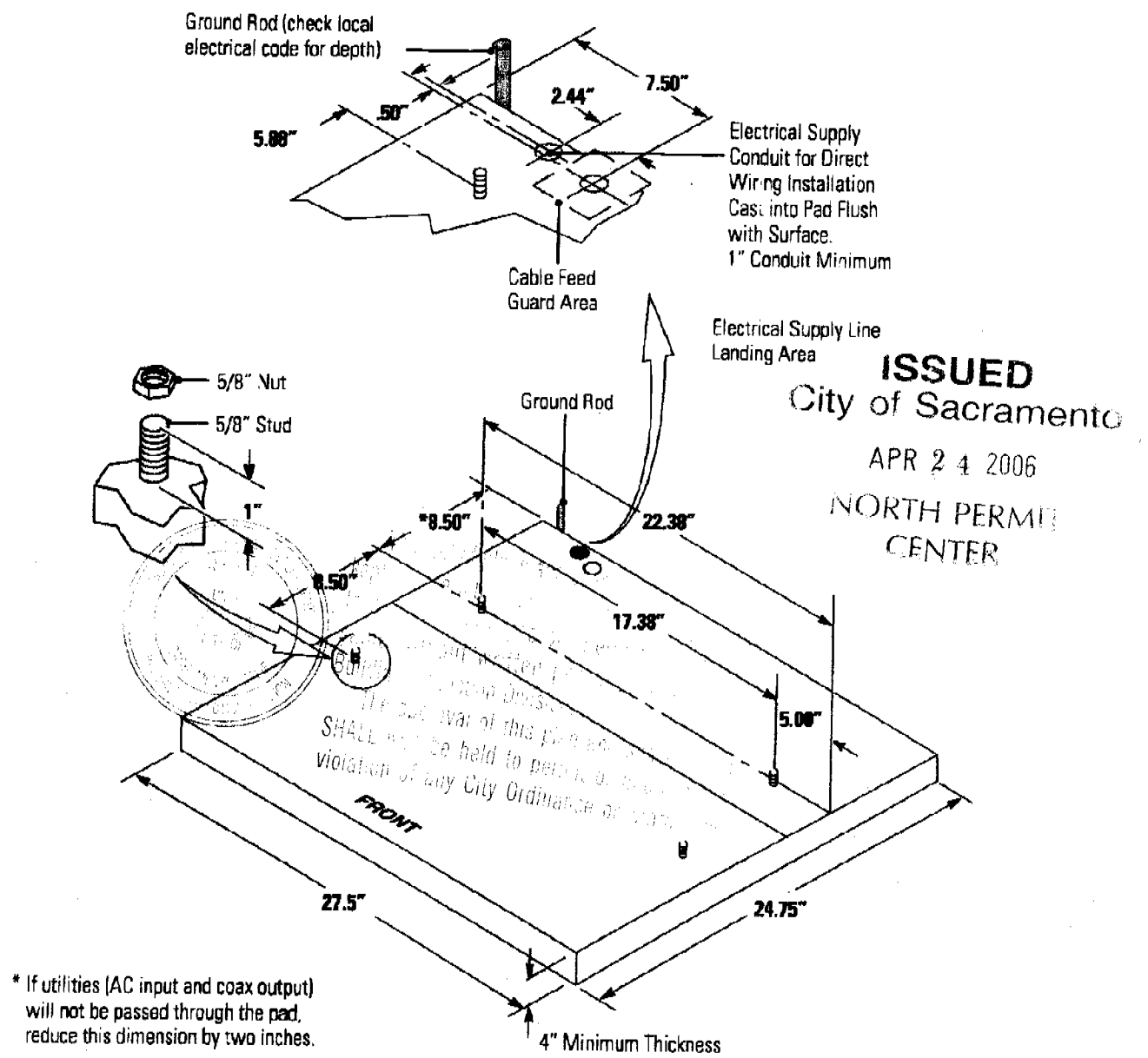

Fig. 2-5 Ground Mount (Cement Pad)

The approval of all Electrical Work is subject to field inspections



NOTE: It is recommended the cement pad dimensions extend beyond the ground skirt on the front and sides and 3-5" in the back.

ISSUED
 City of Sacramento
 APR 24 2006
 NORTH PERMIT
 CENTER

Rating: 200 AMPS, 120/240 VAC, 3 WIRE
 1 PHASE
 METER SOCKET 200 AMPS, CONTINUOUS, 600 VAC
 POWER METER TYPE 3R

STRATEGIC
 TECHNOLOGIES

William Ford
 Operations Manager

4229 Northgate Blvd.
 Suite 7
 Sacramento
 CA 95834
 Office: (916) 641-5990
 Priv. Line: (916) 641-0852
 Fax: (916) 614-8952
 Cell: 916-826-5824
 will@strategic.com

The approval of all Electrical Work
 is subject to field inspections

The approval of this plan and specifications
 SHALL NOT be held to permit or approval of
 violation of any City Ordinance
 is subject to field inspections

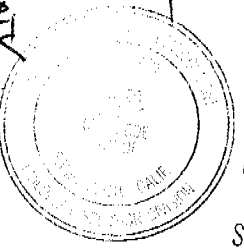

Power Supply/Back up UNIT

