

OFFICE COPY THIS IS A 2 PART FORM
WRITE ON A FIRM SURFACE

USE BLACK INK BALL POINT PEN - PRESS FIRMLY
SIGN PERMIT APPLICATION 264-7559

CONSTRUCTION LENDING AGENCY

I hereby affirm under penalty of perjury that there is a construction lending agency for the performance of the work for which this permit is issued (Sec. 3097, Civ. C.).

Lenders Name _____
Lenders Address _____

LICENSED CONTRACTORS DECLARATION

I hereby affirm under penalty of perjury that I am licensed under provisions of Chapter 9 (commencing with Section 7000) of Division 3 of the Business and Professions Code and my license is in full force and effect.

License Class CVS Lic. Number 423432
Date 1-9-98 Contractor Dr. Ben Thane
(Signature)

OWNER - BUILDER DECLARATION

I hereby affirm under penalty of perjury that I am exempt from the Contractors License Law for the following reason (Sec. 7031.5, Business and Professions Code: Any city or county which requires a permit to construct, alter, improve, demolish, or repair any structure, prior to its issuance, also requires the applicant for such permit to file a signed statement that he or she is licensed pursuant to the provisions of the Contractors License Law (Chapter 9 (commencing with Section 7000) of Division 3 of the Business and Professions Code) or that he or she is exempt therefrom and the basis for the alleged exemption. Any violation of Section 7031.5 by any applicant for a permit subjects the applicant to a civil penalty of not more than five hundred dollars (\$500.00):

I, as owner of the property, or my employees with wages as their sole compensation, will do the work, and the structure is not intended or offered for sale (Sec. 7044, Business and Professions Code: The Contractors License Law does not apply to an owner of property who builds or improves thereon, and who does such work himself or herself or through his or her own employees, provided that such improvements are not intended or offered for sale. If, however, the building or improvement is sold within one year of completion, the owner-builder will have the burden of proving that he or she did not build or improve for the purpose of sale.)

I, as owner of the property, am exclusively contracting with licensed contractors to construct the project (Sec. 7044, Business and Professions Code: The Contractors License Law does not apply to an owner of property who builds or improves thereon, and who contracts for such projects with a contractor(s) licensed pursuant to the Contractors License Law).

I am exempt under Sec. _____ B & P C for this reason _____
Date _____ Owner _____
(Signature)

In issuing this building permit, the applicant represents, and the City relies on the representation of the applicant, that the applicant verified all measurements and locations shown on the application or accompanying drawings and that the improvement to be constructed does not violate any law or private agreement relating to permissible or prohibited locations for such improvements. This building permit does not authorize any illegal location of any improvement or the violation of any private agreement relating to location of improvements.

I certify that I have read this application and state that all information is correct. I agree to comply with all city and county ordinances and state laws relating to building construction and hereby authorize representative of this city to enter upon the abovementioned property for inspection purposes.

Date _____

Signature of Applicant or Agent _____

SITE ADDRESS

5213 Fruitridge Rd

SUITE

INSP AREA

ASSESSOR PARCEL NO. 022-0260-033

PERMIT NO. 9800242

NAME OF APPLICANT

ADDRESS

ZIP CODE

PHONE NO.

LICENSED CONTRACTOR

Russ City Signs

2414 Selles Way

95691

916-3380

BUSINESS OWNER

Ed Hayes, Inc

4936 D. Robertson Way

95628

916-3491

SIGN INFORMATION

ATTACHED INTERIOR / ELECT. SINGLE FACED
 ILLUMINATED NON-ILLUMINATED BILLBOARD / SUBDIVISION
 INDIVIDUAL LETTERS PAINTED ON BUILDING LOGO
 METAL POLE DOUBLE FACED
 PLASTIC MONUMENT VINYL/GATOR FOAM
 WOODEN PROJECTING RE-FACE

SIGN COPY

Fluon Pen Channel Letters

STYLE CENTER C-2

CITY OF SACRAMENTO PERMIT SERVICES
BUILDING INSPECTION DIVISION 264-7619

WORKERS COMPENSATION DECLARATION

I hereby affirm under penalty of perjury one of the following declarations:

I have and will maintain a certificate of consent to self-insure for workers' compensation as provided for by Section 3700 of the Labor Code, for the performance of work for which the permit is issued.

I have and will maintain workers' compensation insurance, as required by Section 3700 of the Labor Code, for the performance of the work for which this permit is issued. My workers' compensation insurance carrier and policy number are: _____

Carrier _____

Policy Number _____

(This section need not be completed if the permit is for one hundred dollars (\$100) or less) I certify that in the performance of the work for which this permit is issued, I shall not employ any person in any manner so as to become subject to the workers' compensation laws of California and agree that if I should become subject to the workers' compensation provisions of Section 3700 of the Labor Code, I shall forthwith comply with those provisions.

Date _____

Applicant _____

Signature _____

NEIGHBORHOOD TRAINING AND DEVELOPMENT SERVICES
CITY OF SACRAMENTO
1000 J STREET, SUITE 100
SACRAMENTO, CA 95811
TEL: 916-433-3333
FAX: 916-433-3333
WWW.CITYOFSA.COM

TOTAL FEES \$

JAN 15 1998

THIS PERMIT SHALL EXPIRE BY LIMITATION IF WORK AUTHORIZED IS NOT COMMENCED WITHIN 180 DAYS

(A) HEIGHT 8'1" (B) LENGTH 10'6"
(A X B) SIGN AREA 5498.5 SQ FT
POLE SIZE 3x4 SIGN SIZE
STREET FRONTAGE (FT) 15
OCCUPANCY FRONTAGE (FT) _____

OFFICE USE ONLY
ENGINEERING REQUIRED? YES NO APPROVED BY _____
DESIGN REVIEW REQUIRED? YES NO APPROVED BY _____
SPECIAL PERMIT REQUIRED? YES NO # _____
VARIANCE REQUIRED? YES NO # _____
LOCATED IN PUD? YES NO WHICH PUD? _____
SIGN VALUATION

A TYPE OF SIGN _____ SQ FT = _____
B _____ PER SQ FT. X _____ SQ FT. = _____
APPROVED BY _____ DATE _____
ISSUED BY _____ DATE _____

FINAL INSPECTIONS
BUILDING INSPECTOR H. Miller DATE 2-4-98
ELECTRICAL INSPECTOR D. Johnson DATE 2-6-98
SIGN INSPECTOR D. Johnson DATE _____
FEES PAID RECEIVED AMOUNT _____
SIGN PERMIT FEE PAID DATE _____
SIGN PERMIT FEE PAID DATE _____

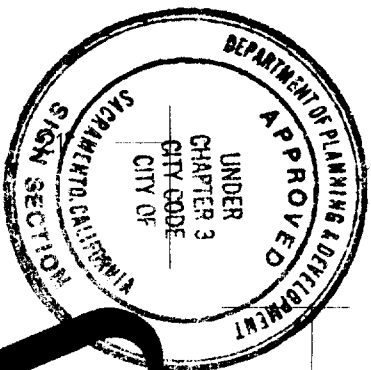

This set of plans and specifications must be kept on the job at all times and it is unlawful to make any changes or alterations from the same without written permission from the City of Sacramento Sign Section.

10'-6"

Approval of this plan and specification shall NOT be held to permit or approve the work of any other person or State or Federal agency with jurisdiction over the project.

EQUIPMENT MUST BE USED AS DESIGN INTENDED

ALL SIGN INSTALLATIONS ARE SUBJECT TO FIELD INSPECTIONS

PAN CHANNEL LTRS - INT. ILLUM.

5" ALUMINUM RETURNS - BRONZE

3/4" TRIM CAP - WHITE

3/16" PLEX FACES - 607 BLUE LETTERS,

WHITE LOGO w/ BLACK VINYL BKGD.

NEON ILLUMINATION - POWDER BLUE LTRS.

- WHITE LOGO

RACEWAY - REMOTE

15' FRONTAGE

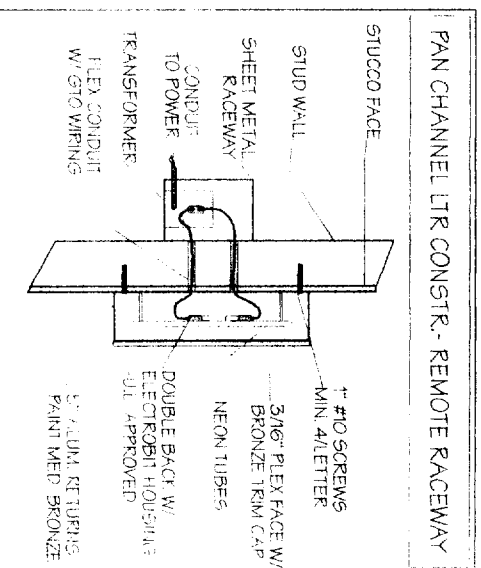

PAN CHANNEL LTR CONSTR. - REMOTE RACEWAY

StylezCenter

FILE COPY

S-19815

PER# 9800242

← 15' FRONTAGE →

StylezCenter

