

CITY OF SACRAMENTO  
1231 I Street, Sacramento, CA 95814

Permit No: 0013265

Insp Area: 1

Site Address: 1312 P ST SAC  
Parcel No: 006-0284-034

CAPITOL PARK HOMES LOT 24  
Sub-Type: NSFR  
Housing (Y/N): N

CONTRACTOR  
CAPITOL PARK HOMES  
818 19TH ST STE 200  
SACRAMENTO CA 95814

OWNER

ARCHITECT

Nature of Work: MP 1609 3 STORY 6 ROOM SFR

**CONSTRUCTION LENDING AGENCY:** I hereby affirm under penalty of perjury that there is a construction lending agency for the performance of the work for which this permit is issued (Sec. 3097, C.P.C.)

Lender's Name \_\_\_\_\_ Lender's Address \_\_\_\_\_

**LICENSED CONTRACTORS DECLARATION:** I hereby affirm under penalty of perjury that I am licensed under provisions of Chapter 9 (commencing with section 7000) of Division 3 of the Business and Professions Code and my license is in full force and effect.

License Class B License Number 767087 Date 4-19-01 Contractor Signature [Signature]

**OWNER-BUILDER DECLARATION:** I hereby affirm under penalty of perjury that I am exempt from the contractors License Law for the following reason (Sec. 7031.5, Business and Professions Code, any city or county which requires a permit to construct, alter, improve, demolish, or repair any structure, prior to its issuance, also requires the applicant for such permit to file a signed statement that he or she is licensed pursuant to the provisions of the Contractors License Law (Chapter 9 (commencing with Section 7000) of Division 8 of the Business and Professions Code) or that he or she is exempt therefrom and the basis for the alleged exemption. Any violation of Section 7031.5 by any applicant for a permit subjects the applicant to a civil penalty of not more than five hundred dollars (\$500.00).

\_\_\_\_\_, I, as a owner of the property, or my employees with wages as their sole compensation, will do the work, and the structure is not intended or offered for sale (Sec. 7044, Business and Professions Code). The Contractors License Law does not apply to an owner of property who builds or improves thereon, and who does such work himself or herself or through his/her own employees, provided that such improvements are not intended or offered for sale. If, however, the building or improvement is sold within one year of completion, the owner-builder will have the burden of proving that he/she did not build or improve for the purpose of sale.

\_\_\_\_\_, I, as owner of the property, am exclusively contracting with licensed contractors to construct the project (Sec. 7044, Business and Professions Code). The Contractors License Law does not apply to an owner of property who builds or improves thereon, and who contracts for such projects with a contractor(s) licensed pursuant to the Contractors License Law.

\_\_\_\_\_, I am exempt under Sec. \_\_\_\_\_ B & P for this reason: \_\_\_\_\_

Date \_\_\_\_\_ Owner Signature \_\_\_\_\_

**IN ISSUING THIS BUILDING PERMIT,** the applicant represents, and the city relies on the representation of the applicant, that the applicant verified all measurements and locations shown on the application or accompanying drawings and that the improvement to be constructed does not violate any law or private agreement relating to permissible or prohibited locations for such improvements. This building permit does not authorize any illegal location of any improvement or the violation of any private agreement relating to location of improvements.

I certify that I have read this application and state that all information is correct. I agree to comply with all city and county ordinances and state laws relating to building construction and hereby authorize representative(s) of this city to enter upon the abovementioned property for inspection purposes.

Date 4-19-01 Applicant Agent Signature [Signature]

**WORKER'S COMPENSATION DECLARATION:** I hereby affirm under penalty of perjury one of the following declarations:

\_\_\_\_\_, I have and will maintain a certificate of consent to self-insure for workers' compensation as provided for by Section 3700 of the Labor Code, for the performance of work for which the permit is issued.

\_\_\_\_\_, I have and will maintain workers' compensation insurance, as required by Section 3700 of the Labor Code, for the performance of the work for which this permit is issued. My workers' compensation insurance carrier and policy number are:

Carrier Binder Policy Number 700 Exp Date \_\_\_\_\_

This section need not be completed if the permit is for \$100 or less. I certify that in the performance of the work for which this permit is issued, I shall not employ any person in any manner so as to become subject to the Workers' Compensation Laws of California and agree that if I should become subject to the workers' compensation provisions of Section 3700 of the Labor Code, I shall forthwith comply with those provisions.

Date 4-19-01 Applicant Signature [Signature]

WARNING: FAILURE TO SECURE WORKER'S COMPENSATION COVERAGE IS UNLAWFUL AND SHALL SUBJECT AN EMPLOYER TO CRIMINAL PENALTIES AND CIVIL FINES UP TO ONE HUNDRED THOUSAND DOLLARS (\$100,000) IN ADDITION TO THE COST OF COMPENSATION, DAMAGES AS PROVIDED FOR IN SECTION 3706 OF THE LABOR CODE, INTEREST AND ATTORNEY'S FEE.

**THIS PERMIT SHALL EXPIRE BY LIMITATION IF WORK IS NOT COMMENCED WITHIN 180 DAYS.**

RESIDENTIAL SUBDIVISION BUILDING PERMIT APPLICATION

0013265 PLAN 3

Project Address: 1312 P Street  
Lot Number: 24

Assessor Parcel # 006-0284-034  
Subdivision CAPITOL PARK HOMES

OWNER INFORMATION:

Legal Property Owner: SHASTA/DOWNTOWN SINGLE FAMI Phone# 449-8989  
Owner Address: 818 19<sup>th</sup> ST City SACRAMENTO State CA Zip 95814

CONTRACTOR INFORMATION:

Contractor: CNM CONST. Lic. # 767087 Phone # 449-8989 Fax 449-8865

PROJECT INFORMATION:

Land Use Zone R1A Occupancy Group R3 Construction Type VN Fed Code 1A  
No. of Stories: 3 No. of Rooms: 10 Street Width: 20  
1<sup>st</sup> Floor Area 4110 2<sup>nd</sup> Floor Area 499 Basement - Roof Material COMP

AREA IN SQUARE FOOT OF:

Dwelling/Living 1609  
Garage/Storage 499 / 538  
Decks/Balconies 130  
Carports -

SCOPE OF WORK: NEW SINGLE FAMILY RESIDENCE

FOR OFFICE USE ONLY

- Information Above Complete
- Violation Files Checked
- Standard Setbacks
- County Sewer
- AR Flood Waiver Required
- Flood Elevation Certificate Required
- Water Development Infill Area
- Planning Approval
- Design Review Approval
- Special Fee Districts Apply:

THE FOLLOWING MUST BE PROVIDED IN ORDER TO SUBMIT FOR PERMIT

- 2 COMPLETE PLOT PLANS, LEGIBLE & DRAWN TO SCALE
- 11 X 17 COPY OF FLOOR PLAN WITH FOLLOWING INFORMATION
  - a) Assessor's Parcel Number
  - b) New Floor Area
  - c) Owners Name
  - d) Project Address

Date: \_\_\_\_\_ Received by: (staff) \_\_\_\_\_ Permit # \_\_\_\_\_

# CERTIFICATION OF INSULATION

CNM CONST.

LOT # 24

1312 P St

CAPITOL PARK HOMES

- P.O. BOX 854, WEST SACRAMENTO, CA 95691 LIC. #202026
- 1309 MELODY ROAD, MARYSVILLE, CA 95901 LIC. #202026
- P.O. BOX 9651, FRESNO, CA 93793-9651 LIC. #202026
- P.O. BOX 1631, RENO, NV 89505 LIC. #10675
- 3326 A PONDEROSA WAY, LAS VEGAS, NV 89118 LIC. #10675

DATE INSULATION COMPLETED  
12-5-01

PARTIAL INSULATION

WALLS	CEILING	FLOOR
( SQUARE FEET )	( SQUARE FEET )	( SQUARE FEET )
MATERIAL <b>FIBERGLASS</b>	MATERIAL <b>FIBERGLASS</b>	MATERIAL <b>FIBERGLASS</b>
FORM <b>BATTS</b>	FORM <b>BATTS &amp; BLOW</b>	FORM <b>BATTS</b>
MANUFACTURER'S PRODUCT I.D.	MANUFACTURER'S PRODUCT I.D.	MANUFACTURER'S PRODUCT I.D.
<b>OCF</b>	<b>OCF</b>	<b>OCF</b>
	BAGS	
INSTALLED	THICKNESS	INSTALLED
<b>13</b>	<b>3 5/8"</b>	<b>30</b>
	R-VALUE	THICKNESS
	<b>9"</b>	

MATERIAL <b>FIBERGLASS</b>	FORM <b>BATTS</b>	R-VALUE	MANUFACTURER <b>OCF</b>
-------------------------------	----------------------	---------	----------------------------

MATERIAL <b>FOAM</b>	MANUFACTURER <b>W-B GRACE</b>
-------------------------	----------------------------------

THIS IS TO CERTIFY THAT INSULATION AND/OR SEALING MATERIALS MEET ALL APPLICABLE MATERIAL STANDARDS AND REGULATIONS.

SIGNATURE - INSULATION CONTRACTOR <i>[Signature]</i>	TITLE <b>MANAGER</b>	DATE <b>12-6-01</b>
SIGNATURE - GENERAL CONTRACTOR	TITLE	DATE

REMARKS:

**Certification of Compliance**  
School District Development

**Part I—To be completed by the APPLICANT**

Owner's Name/Address JHASTA DOWN TOWN SINGLE FAMILY DEV LLC  
Project Address 1312 P ST  
Parcel Number 006-0284-034 Lot No. 24  
Subdivision Name CAPITAL PARK HOMES No. of Units \_\_\_\_\_  
Applicant's Signature [Signature] Title PM  
Phone No. 765-4301 Date 4-5-01

**Notice to Applicant:** Pursuant to Government Code Section 66020(d), this will serve to notify you that the 90-day approval period in which you may protest the fees or other payment identified above will begin to run on the date in which the building or installation permit for this project is issued or on which they are paid to the district(s) or to another public entity authorized to collect them on behalf of the district(s), whichever is earlier.

**Part II—To be completed by the BUILDING DEPARTMENT**

Plan Identification Number 10117  
Building Type (check one)  Residential  Apartment/Condominium  Commercial/Industrial  
Square Feet of Chargeable Building Area 1430  
Signature/Title [Signature] Date 4-5-01

**Part III—To be completed by the SCHOOL DISTRICT**

School District SCUSD Certificate No. 7037  
 Exempt Comments \$452.22 per unit see attachment A  
Residential/Apartment/etc. \_\_\_\_\_ Square ft. x \$ 1.72 = \$ 452.22  
Commercial/Industrial \_\_\_\_\_ Square ft. x \$ \_\_\_\_\_ = \$ \_\_\_\_\_  
Total fees collected..... see #572A = \$ 452.22

*This certification covers only the amount of square footage indicated above. Any additions or corrections to the square footage for this project will require an amendment to the Certificate of Compliance.*

*As the authorized school official, I hereby certify that the requirements of Government Code Section 65995 and any other authorized requirements have been complied with by the above signed applicant.*

Signature [Signature] Date 4/10/01

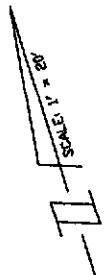
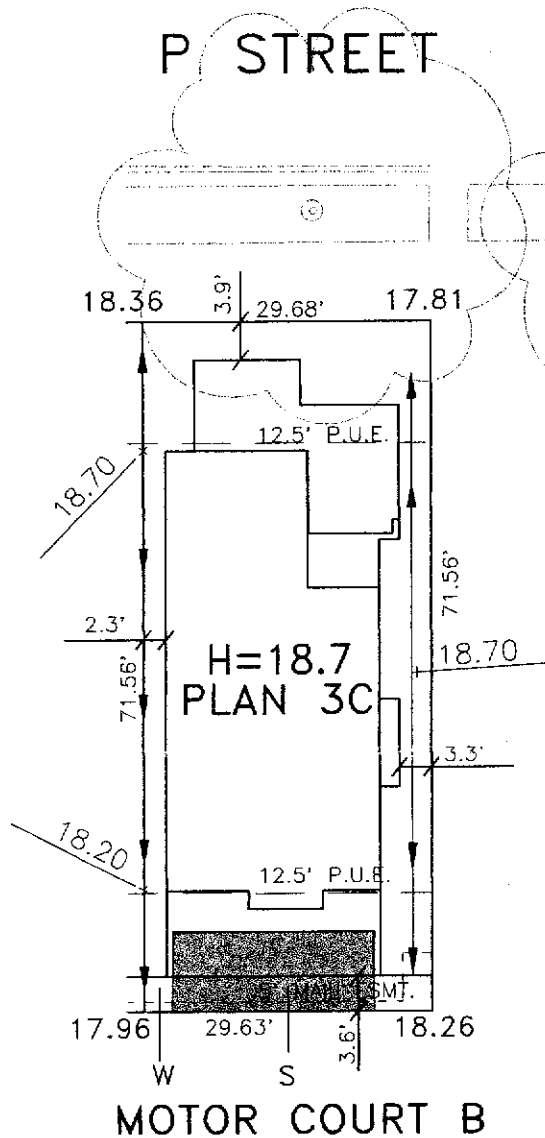

**NOTE:**

This plan is only intended to reference the building plan designated for this lot. All setbacks other than minimum code requirements are approximate. The "as-built" field condition may vary from this plan.

DATE: 10-06-00  
 A.P.N.: 006-2840-034  
 ADDRESS: 1312 P STREET

LOT AREA: 2,122 SF  
 LOT COVERAGE: 55%

**The Spink Corporation**  
 2590 VENTURE OAKS WAY  
 SACRAMENTO, CA. 95833  
 PH (916)925-5550 FAX (916)921-9274

**CAPITOL PARK**  
 LOT 24  
 PLAN 3C

**CAPITOL PARK**  
 CITY OF SACRAMENTO, CA  
 CLIENT: CNM CONSTRUCTION  
 JOB NO.: 1222-002