

CITY OF SACRAMENTO
1231 I Street, Sacramento, CA 95814

Permit No: 0400976

Insp Area: 4

Thos Bros:

Sub-Type: NSFR

Housing (Y/N): N

Site Address: 253 DRAGONFLY CR SAC
Parcel No: RYLAND COTTAGES LOT 38

CONTRACTOR
RYLAND HOMES
1380 LEAD HILL BLVD. STE 108
ROSEVILLE CA. 95661

OWNER
RYLAND HOMES

ARCHITECT

Nature of Work: MP1302 1 STORY 6 ROOM SFR

CONSTRUCTION LENDING AGENCY : I hereby affirm under penalty of perjury that there is a construction lending agency for the performance of the work for which this permit is issued (Sec. 3097, Civ. C).

Lender's Name _____ Lender's Address _____

LICENSED CONTRACTORS DECLARATION: I hereby affirm under penalty of perjury that I am licensed under provisions of Chapter 9 (commencing with section 7000) of Division 3 of the Business and Professions Code and my license is in full force and effect.

License Class B License Number 054648 Date 1.28.04 Contractor Signature [Signature]

OWNER-BUILDER DECLARATION: I hereby affirm under penalty of perjury that I am exempt from the contractors License Law for the following reason (Sec. 7031.5, Business and Professions Code; any city or county which requires a permit to construct, alter, improve, demolish, or repair any structure, prior to its issuance, also requires the applicant for such permit to file a signed statement that he or she is licensed pursuant to the provisions of the Contractors License Law (Chapter 9 (commencing with Section 7000) of Division 8 of the Business and Professions Code) or that he or she is exempt therefrom and the basis for the alleged exemption. Any violation of Section 7031.5 by any applicant for a permit subjects the applicant to a civil penalty of not more than five hundred dollars (\$500.00);

____ I, as a owner of the property, or my employees with wages as their sole compensation, will do the work, and the structure is not intended or offered for sale (Sec. 7044, Business and Professional Code: The Contractors License Law does not apply to an owner of property who builds or improves thereon, and who does such work himself or herself or through his/her own employees, provided that such improvements are not intended or offered for sale. If, however, the building or improvement is sold within one year of completion, the owner-builder will have the burden of proving that he/she did not build or improve for the purpose of sale.)

____ I, as owner of the property, am exclusively contracting with licensed contractors to construct the project (Sec. 7044, Business and Professions Code: The Contractors License Law does not apply to an owner of property who builds or improves thereon, and who contracts for such projects with a contractor(s) licensed pursuant to the Contractors License Law).

____ I am exempt under Sec. _____ B & PC for this reason: _____

Date _____ Owner Signature _____

PAID
CITY OF SACRAMENTO
JAN 28 2004
BUILDING PERMIT

IN ISSUING THIS BUILDING PERMIT, the applicant represents, and the city relies on the representation of the applicant, that the applicant verified all measurements and locations shown on the application or accompanying drawings and that the improvement to be constructed does not violate any law or private agreement relating to permissible or prohibited locations for such improvements. This building permit does not authorize any illegal location of any improvement or the violation of any private agreement relating to location of improvements.

I certify that I have read this application and state that all information is correct. I agree to comply with all city and county ordinances and state laws relating to building construction and hereby authorize representative(s) of this city to enter upon the abovementioned property for inspection purposes.

Date 1.28.04 Applicant/Agent Signature [Signature]

WORKER'S COMPENSATION DECLARATION: I hereby affirm under penalty of perjury one of the following declarations:

____ I have and will maintain a certificate of consent to self-insure for workers' compensation as provided for by Section 3700 of the Labor Code, for the performance of work for which the permit is issued.

I have and will maintain workers' compensation insurance, as required by Section 3700 of the Labor Code, for the performance of the work for which this permit is issued. My workers' compensation insurance carrier and policy number are:

Carrier AMERICAN HOME ASSURANCE Policy Number AOS WC7085227 Exp Date 06/01/2003

____ (This section need not be completed if the permit is for \$100 or less) I certify that in the performance of the work for which this permit is issued, I shall not employ any person in any manner so as to become subject to the workers' compensation laws of California and agree that if I should become subject to the workers' compensation provisions of Section 3700 of the Labor Code, I shall forthwith comply with those provisions.

Date 1.28.04 Applicant Signature [Signature]

WARNING: FAILURE TO SECURE WORKER'S COMPENSATION COVERAGE IS UNLAWFUL AND SHALL SUBJECT AN EMPLOYER TO CRIMINAL PENALTIES AND CIVIL FINES UP TO ONE HUNDRED THOUSAND DOLLARS (\$100,000) IN ADDITION TO THE COST OF COMPENSATION, DAMAGES AS PROVIDED FOR IN SECTION 3706 OF THE LABOR CODE, INTEREST AND ATTORNEY'S FEE.

THIS PERMIT SHALL EXPIRE BY LIMITATION IF WORK IS NOT COMMENCED WITHIN 180 DAYS.

38CT

SCALE: 1"=20'



This set of plans and specifications must be kept on the job at all times. It is unlawful to make any changes or alterations from the same without written permission from the Building Inspection Division.

The approval of this plan and specification SHALL NOT be held to permit or approve the violation of any City Ordinance or State Law.

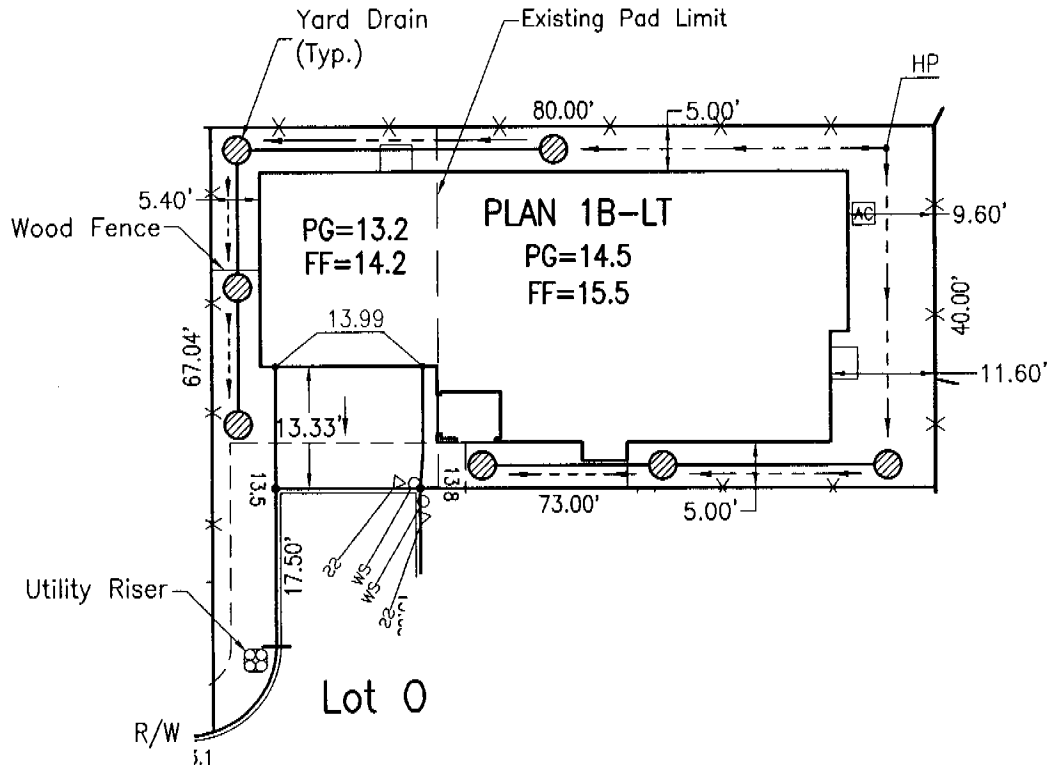

DIMENSIONS SHOWN ARE APPROXIMATE, EXCEPT FOR MINIMUMS REQUIRED BY ORDINANCE. THIS PLOT DOES NOT REFLECT AS-BUILT CONDITIONS WHICH MAY VARY FROM THIS PLAN.

DC
RJA

BW ENGINEERING
BW SURVEYING
BW PLANNING
BAKER-WILLIAMS ENGINEERING GROUP
6020 Rutland Drive, Suite 19 Carmichael, California 95608
(916) 331-4336
(Fax) 331-4430

Ryland Cottages
by *Ryland Homes Inc.*

PLOT PLAN FOR LOT 38

Address: 253 Dragonfly Circle
City of Sacramento, Sacramento Co.

Lot Area: 3371 s.f.
A.P.N.: 225-1900-084

SCALE : 1"=20'
Date: Sep 5, 2003
Revised:
Drawn By: SAK
Job No.: 03-05-051

INSULATION CERTIFICATE

253 DRAGONFLY CIR

SACRAMENTO, CA

Address of Property

County Job No.

County Bid Permit No.

LAS CASITAS

38, LOTS 28-41

SACRAMENTO

Development

Lot, Section

County

EXTERIOR WALLS

Type of Material	<u>BATTS</u>	Manufacturer: <u>Knauf</u>	Thickness: <u>3.5"</u>	R Value: <u>R13</u>
Type of Material	<u>BATTS</u>	Manufacturer: <u>Knauf</u>	Thickness: <u>3.5"</u>	R Value: <u>R13</u>
Type of Material	_____	Manufacturer: <u>Knauf</u>	Thickness: _____	R Value: <u>R13</u>

FLAT CEILING

Type of Material	_____	Manufacturer: <u>Cerainteed</u>	Thickness: _____	R Value: <u>R30</u>
	<u>1131.00</u> Sq. Ft. Covered	<u>17</u> No. of Bags	_____ Wt./Bag	

FLAT CEILING NOT BLOWABLE

Type of Material	<u>BATTS</u>	Manufacturer: <u>Johns Manville</u>	Thickness: <u>10"</u>	R Value: <u>R30</u>
------------------	--------------	-------------------------------------	-----------------------	---------------------

TUB EXTERIOR WALLS

Type of Material	<u>BATTS</u>	Manufacturer: <u>Knauf</u>	Thickness: <u>3.5"</u>	R Value: <u>R13</u>
Type of Material	<u>BATTS</u>	Manufacturer: <u>Knauf</u>	Thickness: <u>3.5"</u>	R Value: <u>R13</u>

Western Insulation - Sacramento

I CERTIFY UNDER THE PENALTY OF PERJURY UNDER THE LAWS OF THE STATE OF THAT THE FOREGOING IS TRUE AND CORRECT.

General Contractor (Builder)	<u>RYLAND HOMES - LAS CASITAS</u>	Contractors Reg. Number:	_____
Licensed Architect/Engineer:	_____		
By	<u>Bucky Luthery</u>	TITLE:	<u>Auth Agent</u>
Date and Place	<u>5-20-04</u>		