

CITY OF SACRAMENTO

1231 I Street, Sacramento, CA 95814

Permit No: 0318271

Insp Area: 2  
Thos Bros: 317 B7

Site Address: 6670 SOUTH LAND PARK DR SAC  
Parcel No: 024-0373-006

Sub-Type: RES  
Housing (Y/N): N

**CONTRACTOR**  
CREATIVE ROOFING  
1020 TABER ST  
WEST SACRAMENTO, CA 95605

**OWNER**  
JOHNSON SCOTT  
6670 SOUTH LAND PARK D  
SACRAMENTO CA 95831

**ARCHITECT**

**Nature of Work:** RESTRUCTURE ROOF (CONVENTIONALLY FRAMED) RESHEET AND APPLY LITE WEIGHT TILE 33 SQ'S

**CONSTRUCTION LENDING AGENCY:** I hereby affirm under penalty of perjury that there is a construction lending agency for the performance of the work for which this permit is issued (Sec. 3097, Civ. C).

Lender's Name \_\_\_\_\_ Lender's Address \_\_\_\_\_

**LICENSED CONTRACTORS DECLARATION:** I hereby affirm under penalty of perjury that I am licensed under provisions of Chapter 9 (commencing with section 7000) of Division 3 of the Business and Professions Code and my license is in full force and effect.

License Class C39 License Number 438395 Date 11-24-03 Contractor Signature Patricia D. SSO

**OWNER-BUILDER DECLARATION:** I hereby affirm under penalty of perjury that I am exempt from the contractors License Law for the following reason (Sec. 7031.5, Business and Professions Code; any city or county which requires a permit to construct, alter, improve, demolish, or repair any structure, prior to its issuance, also requires the applicant for such permit to file a signed statement that he or she is licensed pursuant to the provisions of the Contractors License Law (Chapter 9 (commencing with Section 7000) of Division 8 of the Business and Professions Code) or that he or she is exempt therefrom and the basis for the alleged exemption. Any violation of Section 7031.5 by any applicant for a permit subjects the applicant to a civil penalty of not more than five hundred dollars (\$500.00);

\_\_\_\_ I, as a owner of the property, or my employees with wages as their sole compensation, will do the work, and the structure is not intended or offered for sale (Sec. 7044, Business and Professional Code: The Contractors License Law does not apply to an owner of property who builds or improves thereon, and who does such work himself or herself or through his/her own employees, provided that such improvements are not intended or offered for sale. If, however, the building or improvement is sold within one year of completion, the owner-builder will have the burden of proving that he/she did not build or improve for the purpose of sale.)

\_\_\_\_ I, as owner of the property, am exclusively contracting with licensed contractors to construct the project (Sec. 7044, Business and Professions Code: The Contractors License Law does not apply to an owner of property who builds or improves thereon, and who contracts to do projects with a contractor(s) licensed pursuant to the Contractors License Law).

\_\_\_\_ I am exempt under Sec. \_\_\_\_\_ B & PC for this reason: \_\_\_\_\_  
Date \_\_\_\_\_ Owner Signature \_\_\_\_\_

PAID  
CITY OF SACRAMENTO  
NOV 21 2003  
BUILDING PERMIT

**IN ISSUING THIS BUILDING PERMIT,** the applicant represents, and the city relies on the representation of the applicant, that the applicant verified all measurements and locations shown on the application or accompanying drawings and that the improvement to be constructed does not violate any law or private agreement relating to permissible or prohibited locations for such improvements. This building permit does not authorize any illegal location of any improvement or the violation of any private agreement relating to location of improvements.

I certify that I have read this application and state that all information is correct. I agree to comply with all city and county ordinances and state laws relating to building construction and hereby authorize representative(s) of this city to enter upon the abovementioned property for inspection purposes.

Date 11-24-03 Applicant/Agent Signature Patricia D. SSO

**WORKER'S COMPENSATION DECLARATION:** I hereby affirm under penalty of perjury one of the following declarations:  
\_\_\_\_ I have and will maintain a certificate of consent to self-insure for workers' compensation as provided for by Section 3700 of the Labor Code, for the performance of work for which the permit is issued.

I have and will maintain workers' compensation insurance, as required by Section 3700 of the Labor Code, for the performance of the work for which this permit is issued. My workers' compensation insurance carrier and policy number are:

Carrier STATE FUND Policy Number 1313938-00 Exp Date 07/01/2004

\_\_\_\_ (This section need not be completed if the permit is for \$100 or less) I certify that in the performance of the work for which this permit is issued, I shall not employ any person in any manner so as to become subject to the workers' compensation laws of California and agree that if I should become subject to the workers' compensation provisions of Section 3700 of the Labor Code, I shall forthwith comply with those provisions.

Date 11-24-03 Applicant Signature Patricia D. SSO

**WARNING:** FAILURE TO SECURE WORKER'S COMPENSATION COVERAGE IS UNLAWFUL AND SHALL SUBJECT AN EMPLOYER TO CRIMINAL PENALTIES AND CIVIL FINES UP TO ONE HUNDRED THOUSAND DOLLARS (\$100,000) IN ADDITION TO THE COST OF COMPENSATION, DAMAGES AS PROVIDED FOR IN SECTION 3706 OF THE LABOR CODE, INTEREST AND ATTORNEY'S FEE.

**THIS PERMIT SHALL EXPIRE BY LIMITATION IF WORK IS NOT COMMENCED WITHIN 180 DAYS.**

**SCHOEN ENGINEERING**

9524 BEDINGTON WAY  
SACRAMENTO, CA 95827  
(916) 369 6866

Licensed by the California State Board  
for Engineers and Land Surveyors  
LIC.# C042913



October 23, 2003

Scott Johnson  
6670 Southland Park Drive  
Sacramento, CA 95831

**SUBJECT:** Reroof at 6670 Southland Park Drive, Sacramento, CA 95831

Scott:

On September 14<sup>th</sup> 2003 I inspected your home at the above mentioned address. I found the roof to be conventionally framed with 2x6 D.F. No. 2 rafters @ 2' o.c. spanning a max. of 14' in the garage and 11' 2" in the attic areas of the house.



This set of plans and specifications must be kept on the job at all times and it is unlawful to make any changes or alterations in the same without written permission from the Building Inspection Division. The approval of this plan and specification SHALL NOT be held to permit or approve the violation of any City Ordinance or State Law.

The following modifications will need to be made prior to reroofing:

- \* In the garage the common rafters and the king rafter in the hip are over span. The hip rafters as well have shown signs of sagging. To remedy this two 1-3/4"x14" Microlam roof support beams should be installed between, and supported by the side walls of the garage. The Microlams may be set on top of the wall plates or supported by top flange hangers(see attached sketch for details and plan for location).
- \* In the back slope of the main wing of the house over the wall separating the main house from the enclosed patio, 2x4 braces should be installed to each rafter not already having a brace (see sketch for details and plan for location).
- \* In the front slope of the main wing of the house and at the south slope of the bedroom wing a new 2x6 purlin should be installed and braced off of the load bearing walls with 2x4 braces @ 6' o.c. (see sketch for details and plan for location).
- \* In the back slope of the main wing over the living room a new 1-3/4"x 11-7/8" Microlam purlin should be installed between the side walls of the living room and supported off of those walls. Also, in the area of the hip at the North end of the main wing of the house a 1-3/4"x11-7/8" Microlam purlin should be installed between the back wall adjacent to the enclosed patio and the central load bearing wall. Where this purlin intersects the valley rafter, the valley rafter should be notched to allow for the proper placement of the purlin underneath the rafters (see sketch for details and plan for location).

\* The ridge of the main wing should be supported with a 1-3/4"x11-7/8" Microlam installed underneath the ridge board and attached to the ridge board with a 2x4 cleat. The Microlam should be supported on bearing walls at either end. The main ridge in this area should have the rafters tied across the top of the ridge with Simpson MST18 steel strap ties installed over the skip sheathing with 5-10d nails into each rafter (see sketch for details and plan for location).

It is my finding that this structure is adequate for the following: 1/2" plywood or 7/16 OSB installed over the existing skip sheathing; Tarred felt or similar underlayment installed on top of the plywood or OSB sheathing; 1x2 battens; Lightweight concrete tile weighing 7.3 lbs/sq. ft. or less.

**NOTE:** It is possible when reroofing that the increased loads to structural elements also supporting wall ceiling and floor finishes could cause some minor cosmetic cracking of these finishes. This is typical of wood framed structures and does not of itself indicate structural inadequacy of these members.

This report deals with the structural adequacy of roof supporting members that were readily observable. It does not address any structure that was covered by wall finishes, buried in the ground or was otherwise not observable. Any such structures were assumed to conform to standard construction specifications in the Uniform Building Code at the time of construction or that they were designed in conformance to engineering criteria in that code. Also, it does not address any existing deflection or warping of roof surfaces or other finish surfaces. There is also no guarantee that any structural modifications listed in this report will remove such deflections or warping. The repair of such deflections or warping is at the option of the building owner and the roofing contractor.

This report has been prepared for the sole benefit of the individual to whom it is addressed. The use of or reliance on this report by any other individuals or entities without the expressed written consent of the above addressee and Schoen Engineering is forbidden. This does not preclude a licensed contractor acting as an agent for the addressee from using this report to obtain a building permit.

I would like to thank you for allowing me to be of service in this matter. Please let me know if I can be of further assistance.

Sincerely

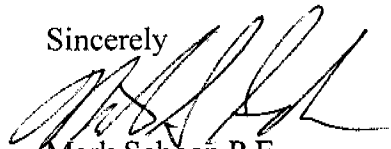

Mark Schoen P.E.

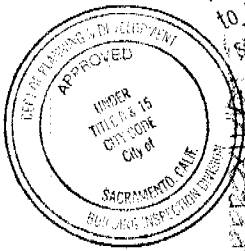

This set of plans is to be kept on the job at all times. No changes or alterations may be made without the written permission of the Building Inspection Division. This set of plans shall not be held to permit approval of any City Ordinance or State Law.

NOTE: LOCATIONS OF NEW PURLINS IS APPROXIMATE. PURLINS MAY BE MOVED UP OR DOWN SLOPE TO FIT AS LONG AS PROPER BRACING & BASE OF INSTALLATION, ASSUMING THE RAPTER SPANS FROM EAVE OR RIDGE TO PURLIN DO NOT EXCEED 12'-0".

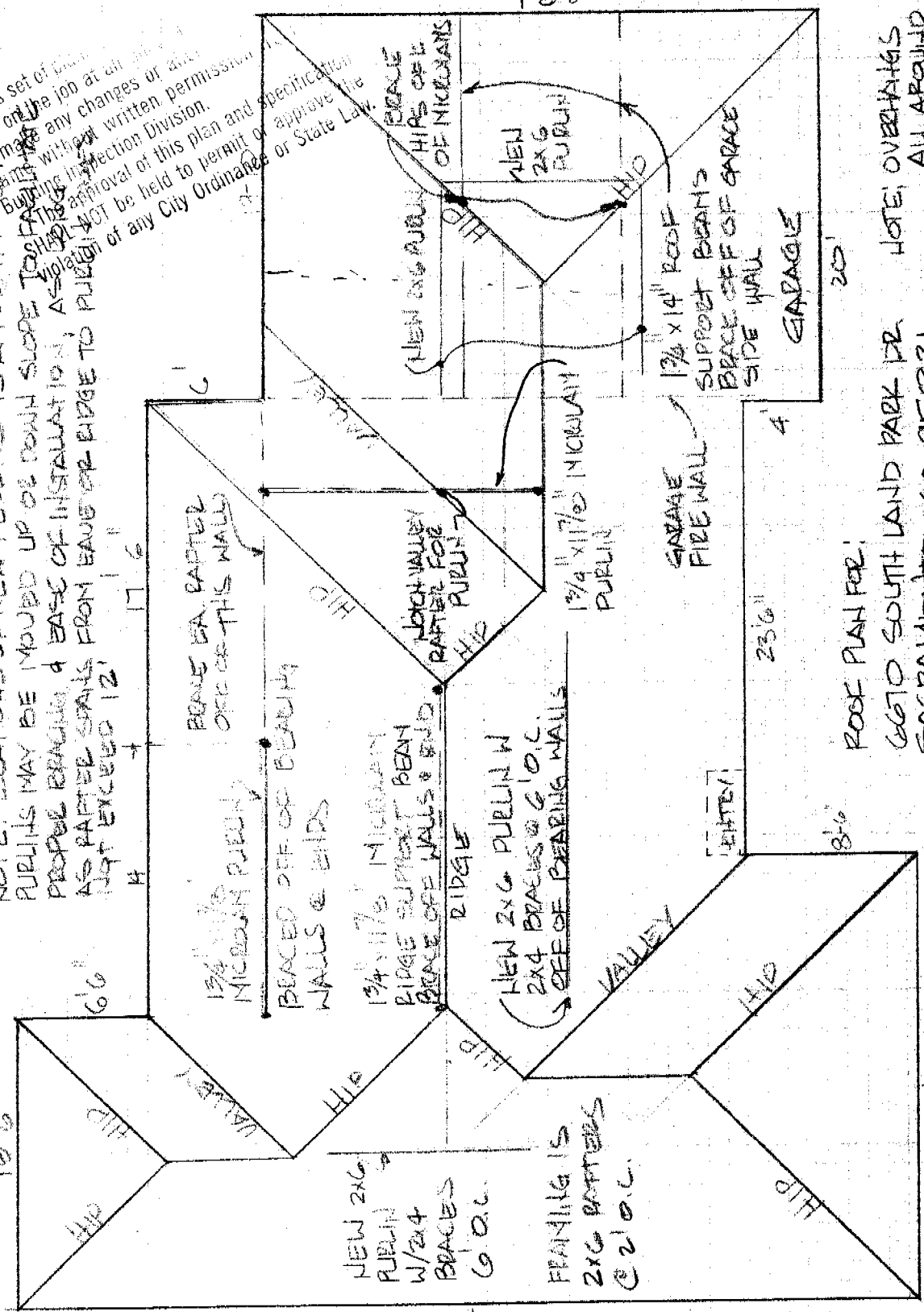

ROOF PLAN FOR:  
 6670 SOUTH LAND PARK DR  
 SACRAMENTO, CA 95831

NOTE: OVERHANGS ALL AROUND NOT SHOWN

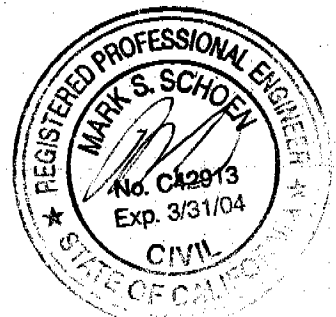

TIE @ 4 O.C. IF TIES ARE PARALLEL TO BEAM INSTALL BLOCKING BETWEEN TIES @ 4 O.C. & ATTACH MICROSLAM TO BLOCKS

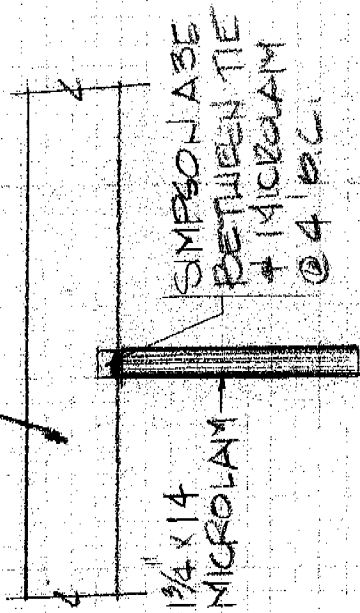

BE OR WIP TOP FLANG HANGER EXTERIOR OR INTERIOR BEARING WALL

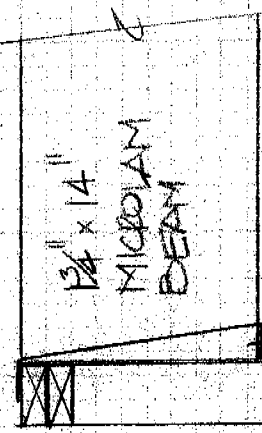

BEAM SUPPORT @ WALL

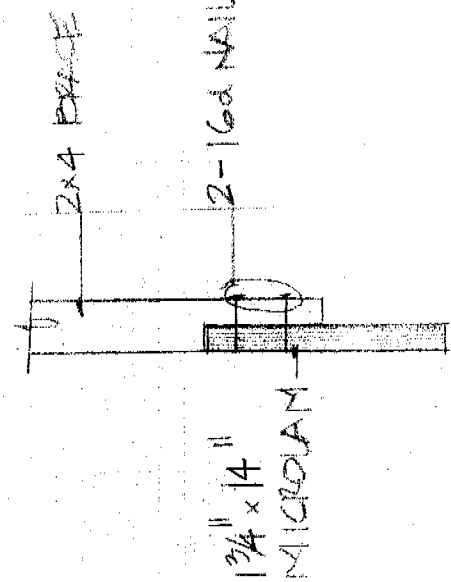

ROOF BRACE TO MICROSLAM

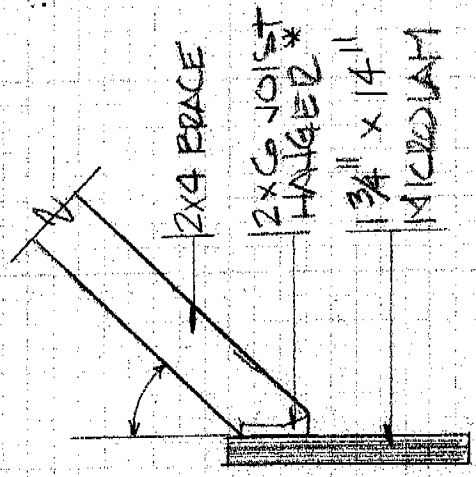

ROOF BRACE TO MICROSLAM

\* IF BRACE IS AT OTHER THAN 90° TO LINE OF MICROSLAM A SKEWER HANGER SHOULD BE USED

ROOF SUPPORT BEAM W/ GARGE

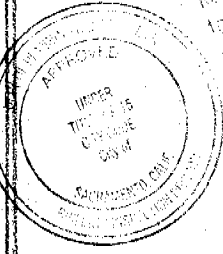

This set of plans and specifications shall be kept on file at all times and shall be subject to make any changes or alterations without the approval of the Building Inspector in District. The approval of this plan and specification SHALL NOT be held to permit or approve the violation of any City Ordinance or State Law.

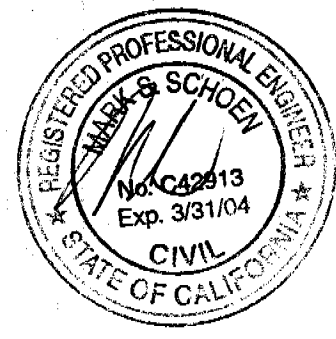

BEARING WALL  
ALSO SUPPORTS  
RAFTERS, MICROLAM  
MAY BE CUT ALONG  
ROOF LINE

(ONLY ONE NEEDED)  
2x4 BRACING TO TOP  
EDGE OF MICROLAM  
O.F. O.C. BRACING  
MAY COME IN FROM  
THE TOP, SIDE OR  
BOTTOM & BE ATTACHED  
TO OTHER WALL, CEILING  
OR ROOF FRAMING

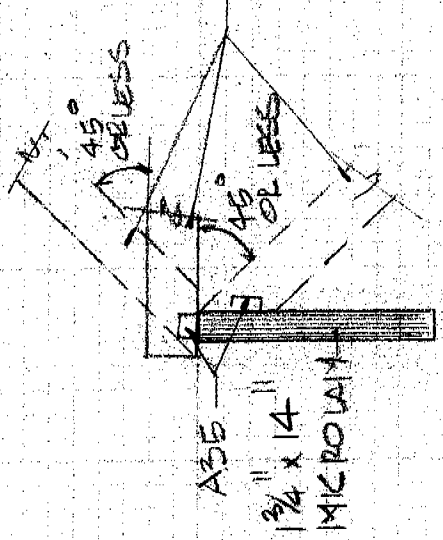

BRACING TO TOP EDGE OF  
MICROLAM

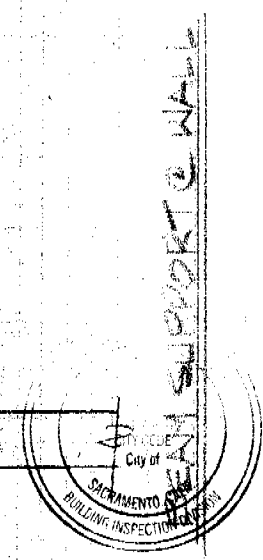
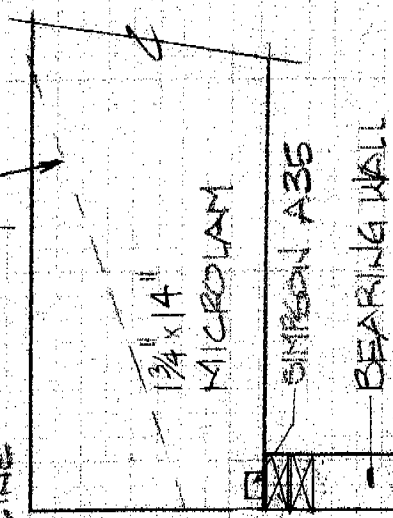

ROOF BRACE TO  
MICROLAM

ROOF BRACE TO  
MICROLAM



ROOF SUPPORT BEAM IN GARAGE  
(ALTERNATE)

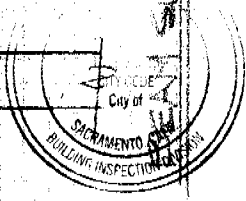

The approval of this plan and specification SHALL NOT be held to permit or approve the violation of any City Ordinance or State Law.



This set of plans and specifications must be kept on the job at all times and it is unlawful to make any changes or alterations from one set, without written permission from the Building Inspection Division.

The approval of this plan and specification SHALL NOT be held to permit or a waiver of a violation of any City Ordinance or State Law.

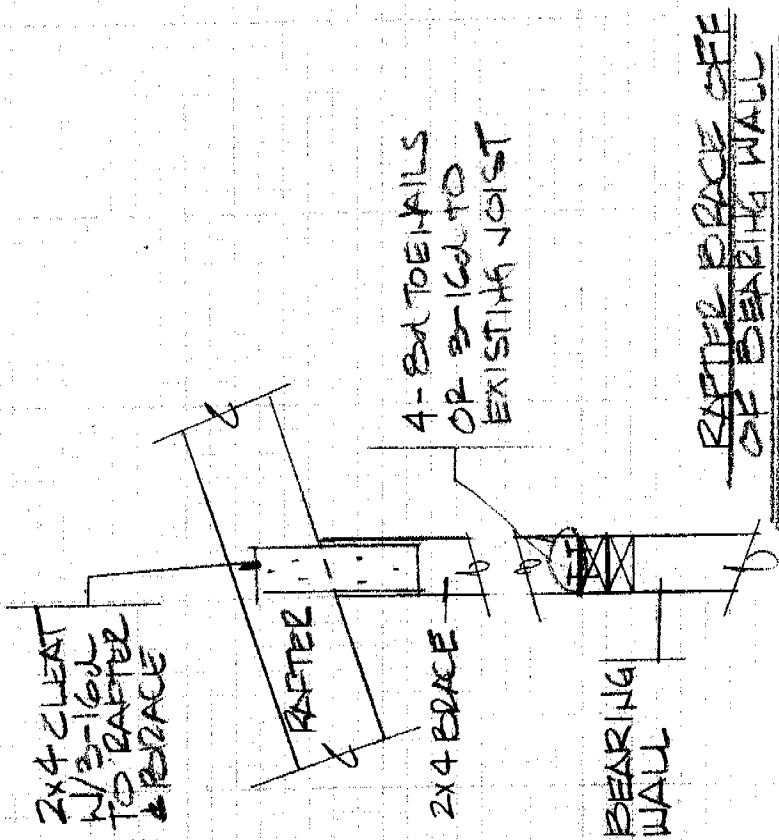

\* BRACES SHOULD BE DOUBLED IF OVER 5' IN LENGTH

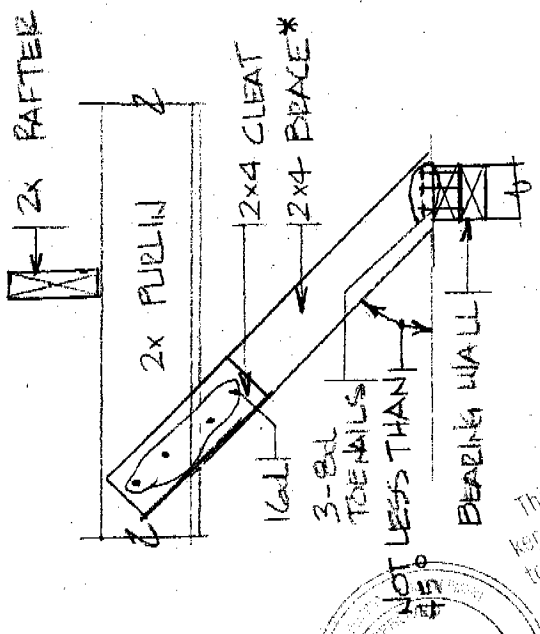

CLEATED PURLIN BRACE (SIDE VIEW)

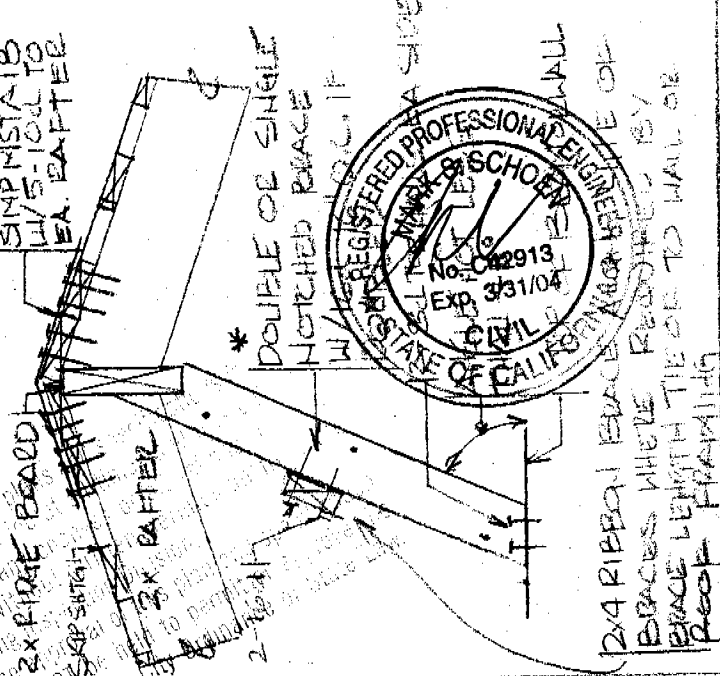

\* DOUBLE OR SINGLE NOTCHED BRACE W/ 5-10d TO EA. RAFTER

NOTE: IF ROULED BRACE IS REQUIRED CLEAT SHOULD EXTEND TO LOAD BEARING WALL

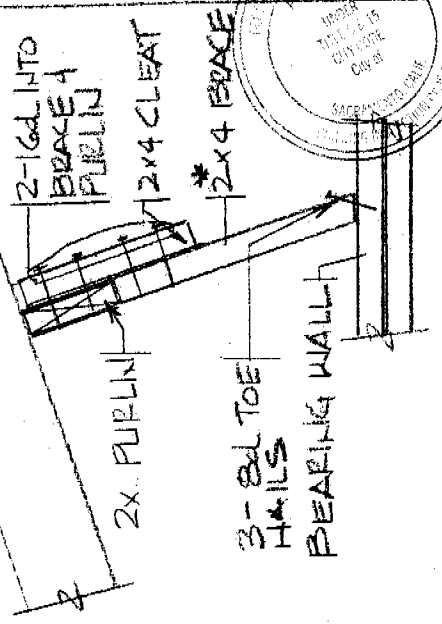

CLEATED PURLIN BRACE (END VIEW)

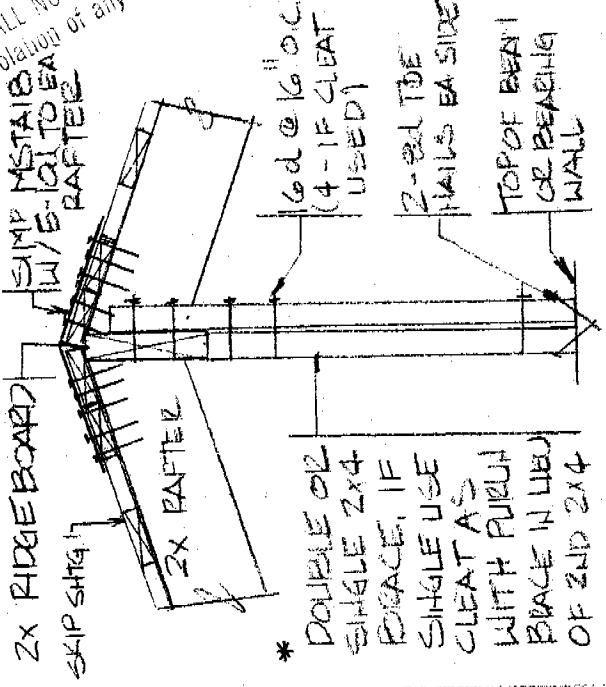

NOTE: BRACE MAY LEAN IN LINE W/ RIDGE BUT @ ANGLE NOT FLATTER THAN 45°

RIDGE BRACE W/ BEARING WALL DIRECTLY UNDER RIDGE

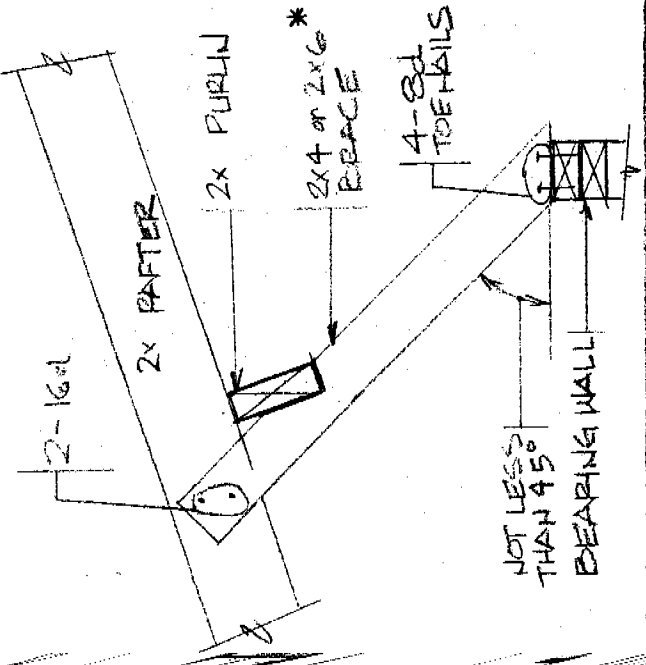

NOTCHED PURLIN BRACE

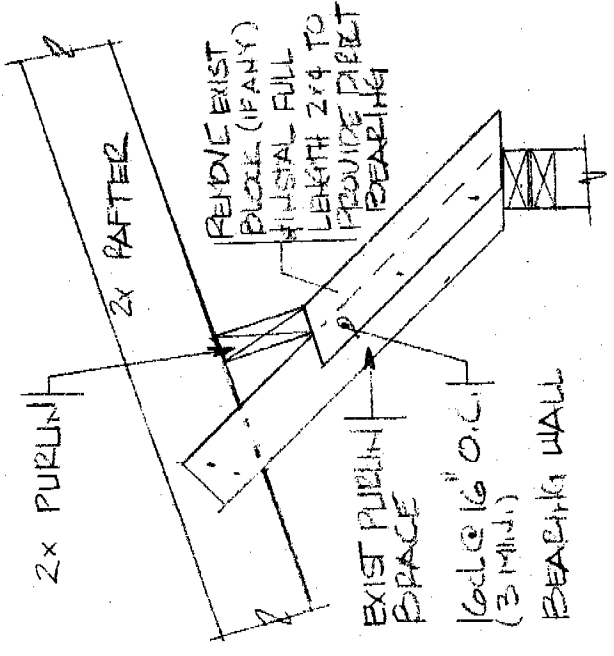

EXISTING BRACE MODIFIED FOR DIRECT BEARING

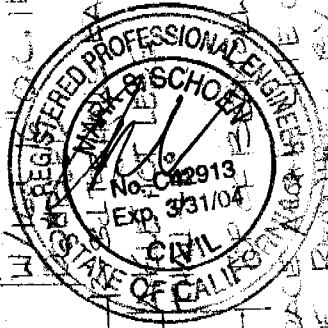



NOTCH FOR RAFTER

2x4 RAFTER

3/4" x 1 1/8" MICROLAM PURLIN W/ 3-16d TO BRACE

2x4 BRACE 4' O.C. W/ 2-16d TO RAFTER & PURLIN

DOUBLED 2x4 PURLIN BRACE @ LOAD BEARING WALLS NAIL EA. R/W TO LDN. W/ 4-8d TENNALS

DOUBLE PLATE OF LOAD BEARING WALL

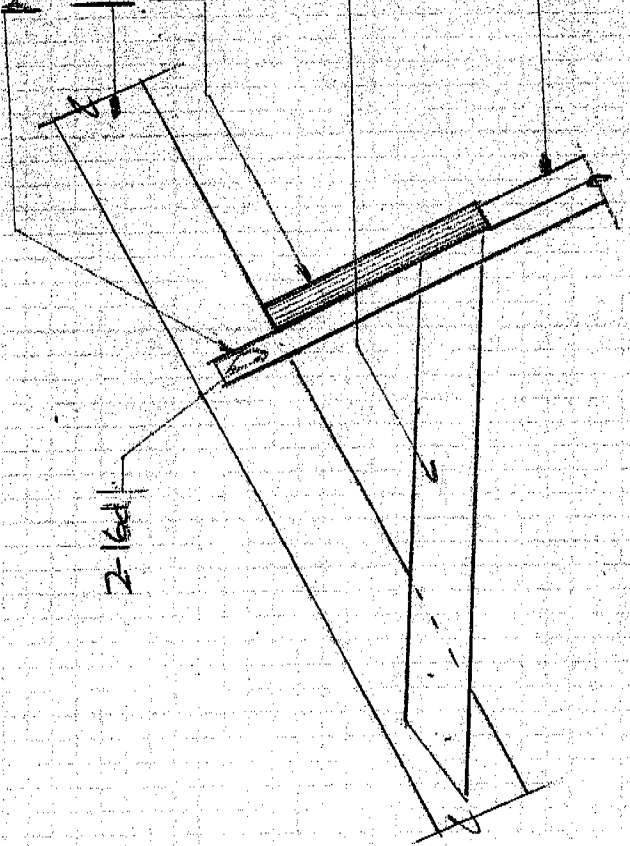

MICROLAM PURLIN & BRACING  
(SECTION)

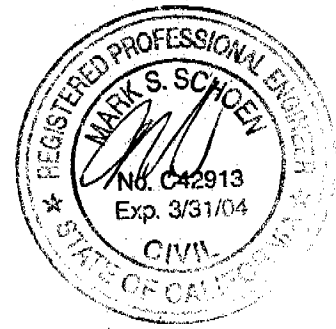

2x6 RAFTER

3/4" x 1 1/8" MICROLAM PURLIN

DOUBLED 2x4 PURLIN BRACES

NOTE: THIS BRACE MA BE SLIGHTLY OFF OF THE VERTICAL TO ALLOW FOR RAFTER LAYOUT

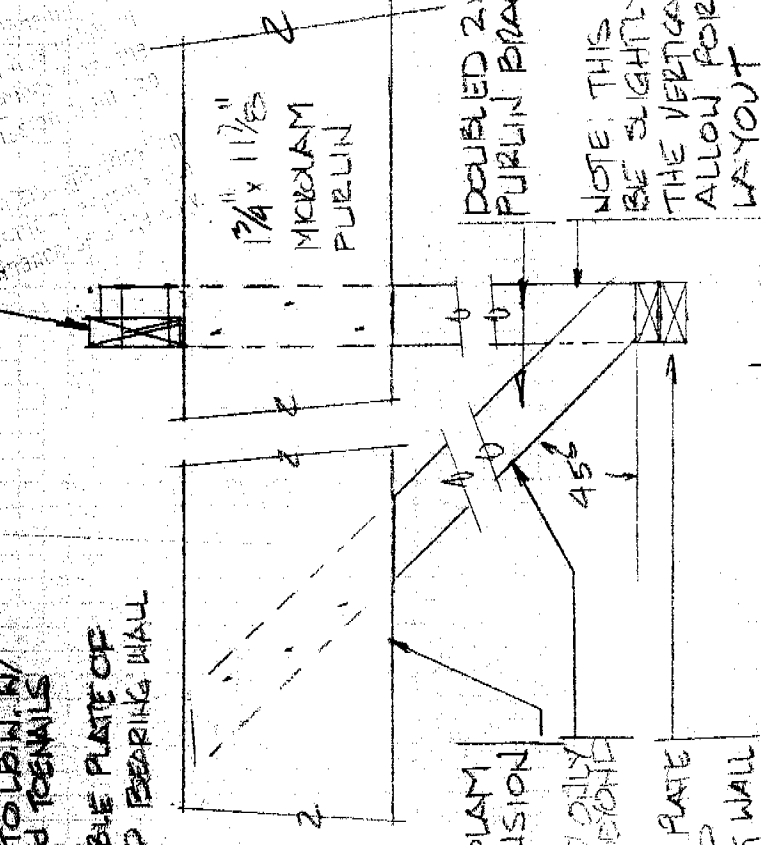

MICROLAM PURLIN & BRACING  
(ELEVATION)

EXIST 2x6  
PARTERS

EXIST RIDGE  
BEAM

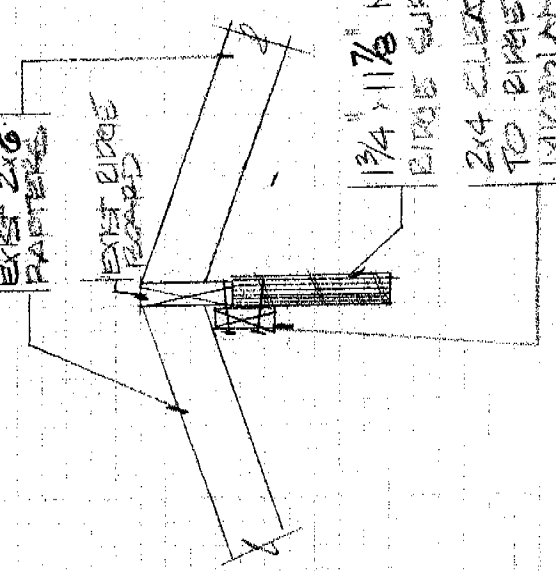

3/4" x 1 1/8" MICROLAM  
RIDGE SUPPORT BEAM

2x4 GLEAT ATTACHED  
TO RIDGE BEAM &  
MICROLAM W/ 10d  
NAILS @ 16" O.C.

MICROLAM RIDGE SUPPORT BEAM

NOTE: SUPPORT & ENDS IS  
THE SAME AS FOR  
DOUBLED RIDGE BRACE  
(SEE BRACE DETAIL SHEET)



I hereby certify that the above is a true and correct copy of the original as shown to me by the applicant and that the same has been filed in my office for the purpose of recording the same.

Witness my hand and the seal of my office this 1st day of March 1974.



Calculation for the required section modulus and moment of inertia for simple span wood beams. Dead load(DL) and Live load(LL) are in pounds per square ft., Spans(L) and Tributary load length or spacing(sp) are in ft., Section moduli are in inches cubed and Moments of inertia are in inches to the 4th power. Allowable stress (Fy) is in lbs./sq.in. per 1997 U.B.C. Section modulus shape factor reduction and load modification are per U.B.C. Sec. 2504.

MICROLAM ROOF SUPPORT PURLINS AND @ BACK SLOPE AND HIP

Loads:

Frame(2x6 rafters): fr:=1 skip sht: pur:=1 Plywood: ply:=1.5

Roofing: rf:=7.3 misc:=.5 Ceiling: clg:=0

Total roof dead load: rdl:=fr+pur+ply+rf+misc+clg

Beam weight: Wdl:=1.75  $\frac{11.875}{144}$  .35 Wdl=5.1 Beam length: l:=15

Roof trib area per ft.: rta:=15.61

Total area for live load determination: rta.l=137.3 Roof live load: rll:=16

Beam load for stress: wt:=rta.(rdl+rll)+Wdl

Beam load for deflection wtδ:=rta.(rdl.5+rll)+Wdl.5

Live load duration factor Cd:=1.25

E:=1900000 Fb:=2600.1.25

$$S \text{ min. required} = \frac{(wt) \cdot l^2 \cdot 1.5}{Fb} = 26.5$$

$$I \text{ min. required} = \frac{5 \cdot wt\delta \cdot (1.12)^4}{12 \cdot 384 \cdot E \cdot l \cdot \frac{12}{240}} = 160.4$$

End reactions:  $R := wt \cdot \frac{l}{2}$  R = 1911.3

Check 1-3/4"x11-7/8" Microlam purlin:

w:=1.75 d:=11.875

$$Cf := \left( \frac{12}{d} \right)^{\frac{1}{9}}$$

$$S := Cf \cdot w \cdot \frac{d^2}{6} \quad I := w \cdot \frac{d^3}{12}$$

S = 41.2 > 27 I = 244.2 > 160 therefore O.K.



MICROLAM ROOF SUPPORT BEAMS IN GARAGE

---

Loads:

Frame(2x6 rafters): fr:=1 skip sht: pur:=1 Plywood: ply:=1.5

Roofing: rf:=7.3 misc:=.5 Ceiling: clg:=0

Total roof dead load: rdl:=fr+pur+ply+rf+misc+clg

Beam weight: Wdl:=1.75  $\frac{14}{144}$  .35 Wdl=6 Beam length: l:=20

Roof trib area per ft.: rta:=14.61

Total area for live load determination: rta.l=170.8

Roof live load: rll:=16

Beam load for stress: wt:=rta.(rdl+rll)+Wdl

Beam load for deflection wtδ:=rta.(rdl.5+rll)+Wdl.5

Live load duration factor Cd:=1.25

E:=1900000 Fb:=2600.1.25

S min. required =  $(wt) \cdot l^2 \cdot \frac{1.5}{Fb} = 44.1$

I min. required =  $\frac{5 \cdot wt \delta \cdot (l \cdot 12)^4}{12 \cdot 384 \cdot E \cdot l \cdot \frac{12}{240}} = 356$

End reactions: R := wt  $\frac{1}{2}$  R = 2391

Check 1-3/4"x14" Microlam purlin:

w:=1.75 d:=14 Cf:=  $\left( \frac{12}{d} \right)^{\frac{1}{9}}$

S:=Cf.w  $\frac{d^2}{6}$  I:=w  $\frac{d^3}{12}$

---

S = 56.2 > 44 I = 400.2 > 356 therefore O.K.

---

