

CITY OF SACRAMENTO

Permit No: 9802027

1231 I Street, Sacramento, CA 95814

Insp Area: 2

Site Address: 82 NORTHLITE CR SAC

Sub-Type: ASFR

Parcel No: 0300610022

Housing (Y/N): N

CONTRACTOR

SIERRA PACIFIC HOME & COMFORT
3790 OMEL CR
RANCHO CORDOVA, CA
Phone: 916-638-0543

OWNER

EATON AUSTIN D & CYNTHIA Y
82 NORTHLITE CR
SACRAMENTO CA 95831
Phone:

ARCHITECT

Phone:

Nature of Work: SOLAR PANELS FOR POOL HEAT

CONSTRUCTION LENDING AGENCY: I hereby affirm under penalty of perjury that there is a construction lending agency for the performance of the work for which this permit is issued (Sec. 3097, Civ. C).

Lender's Name CASH Lender's Address

LICENSED CONTRACTORS DECLARATION: I hereby affirm under penalty of perjury that I am licensed under provisions of Chapter 9 (commencing with section 7000) of Division 3 of the Business and Professions Code and my license is in full force and effect.

License Class 20 License Number 453302 Date 3/24/98 Contractor Signature [Signature]

OWNER-BUILDER DECLARATION: I hereby affirm under penalty of perjury that I am exempt from the contractors License Law for the following reason (Sec. 7031.5, Business and Professions Code; any city or county which requires a permit to construct, alter, improve, demolish, or repair any structure, prior to its issuance, also requires the applicant for such permit to file a signed statement that he or she is licensed pursuant to the provisions of the Contractors License Law (Chapter 9 (commencing with Section 7000) of Division 8 of the Business and Professions Code) or that he or she is exempt therefrom and the basis for the alleged exemption. Any violation of Section 7031.5 by any applicant for a permit subjects the applicant to a civil penalty of not more than five hundred dollars (\$500.00);

I, as a owner of the property, or my employees with wages as their sole compensation, will do the work, and the structure is not intended or offered for sale (Sec. 7044, Business and Professional Code: The Contractors Law does not apply to an owner of property who builds or improves thereon, and who does such work himself or herself or through his or her own employees, provided that such improvements are not intended or offered for sale. If, however, the building or improvement is sold within one year of completion, the owner-builder will have the burden of proving that he or she did not build or improve for the purpose of sale.)

I, as owner of the property, am exclusively contracting with licensed contractors to construct the project (Sec. 7044, Business and Professions Code: The contractors License Law does not apply to an owner of property who builds or improves thereon, and who contracts for such projects with a contractor(s) licensed pursuant to the Contractors License Law).

I am exempt under Sec. B & PC for this reason:

Date Owner Signature

IN ISSUING THIS BUILDING PERMIT, the applicant represents, and the city relies on the representation of the applicant, that the applicant verified all measurements and locations shown on the application or accompanying drawings and that the improvement to be constructed does not violate any law or private agreement relating to permissible or prohibited locations for such improvements. This building permit does not authorize any illegal location of any improvement or the violation of any private agreement relating to location of improvements.

Date 3/24/98 Applicant/Agent Signature [Signature]

WORKER'S COMPENSATION DECLARATION: I hereby affirm under penalty of perjury one of the following declarations:

I have and will maintain a certificate of consent to self-insure for workers' compensation as provided for by Section 3700 of the Labor Code, for the performance of work for which the permit is issued.

I have and will maintain workers' compensation insurance, as required by Section 3700 of the Labor Code, for the performance of the work for which this permit is issued. My workers' compensation insurance carrier and policy number are:

Carrier GOLDEN BEAR Policy Number LWC 543316-03

(This section need not be completed if the permit is for \$100 or less) I certify that in the performance of the work for which this permit is issued, I shall not employ any person in any manner so as to become subject to the workers' compensation laws of California and agree that if I should become subject to the workers' compensation provisions of Section 3700 of the Labor Code, I shall forthwith comply with those provisions.

Date 3/24/98 Applicant Signature [Signature]

WARNING: FAILURE TO SECURE WORKER'S COMPENSATION COVERAGE IS UNLAWFUL AND SHALL SUBJECT AN EMPLOYER TO CRIMINAL PENALTIES AND CIVIL FINES UP TO ONE HUNDRED THOUSAND DOLLARS (\$100,000) IN ADDITION TO THE COST OF COMPENSATION, DAMAGES AS PROVIDED FOR IN SECTION 3706 OF THE LABOR CODE, INTEREST AND ATTORNEY'S FEE.

THIS PERMIT SHALL EXPIRE BY LIMITATION IF WORK IS NOT COMMENCED WITHIN 180 DAYS.

82 Northlite
98020272(K)

CITY OF SACRAMENTO
DEVELOPMENT SERVICES DIVISION

EXPRESS PLAN REVIEW

DATES					
1ST REVIEW		RECHECK		2ND RECHECK	
IN	OUT	IN	OUT	IN	OUT
3/16/98	/ /	/ /	/ /	/ /	/ /

PLAN CHECK NO.	COMM	RES.
----------------	------	------

CONTACT PERSON: DAN MCNAM PHONE: 98020272
 PROJECT: 82 NORTH LITE - CH FAX: _____

DESCRIPTION OF WORK: SOLDER HEAT FOR POOL

DISCIPLINE	1ST REVIEW			RECHECK			2ND RECHECK		
	EPR	OC	APPR	EPR	OC	APPR	EPR	OC	APPR
MECHANICAL									
MICROFILM/ANNEX									
ELECTRICAL									
FIRE									
PLUMBING									

Legend:
 EPR = OK for Express Plan Review
 OC = OK for Over the Counter Rercheck
 APPR = Approved as submitted

ISSUED

MAR 24 1998



9x12 SWEEP DELAY 6155 75 6230 DISCOUNT 700 5530 250 DISCOUNT 5280

CITY OF SACRAMENTO DEVELOPMENT SERVICES DIV

3790 OMEC CIRCLE • RANCHO CORDOVA, CALIFORNIA 95742 • (916) 638-0543 Calif. State Contractor's License No. 453302

INSTALLATION DIRECTIVE

CUSTOMER AUSTIN/CINDY EATON MAP COORD ADDRESS 82 NORALIGHT CR. DIRECTIONS TO JOB SITE: CITY SACTO, CA. PHONE: work (his) work (hers) home 391-2155 DATE OF ORDER 2/28/98 BUILDER AQUARIUS DESIGNER GENE G.

EQUIPMENT LIST 8 12' Solar Panels LX220 Type Of Control 10' Solar Panels 1 System Assembly Package 8' Solar Panels Sweep Delay 8 Fiberglass Substrate Existing Control Type



TYPE OF ROOF SHAKE PITCH 4/12 COMPASS DIRECTION 60% POOL AREA SQ. FT. 750 SHADE ON POOL? N/A ON ROOF? N/A PUMP H.P. 20 TYPE CLEANER ARNESON w/ Pump 1 Story 2 Story

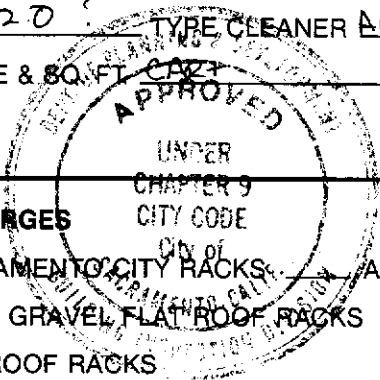

FILTER TYPE & SQ. FT. HEATER SIZE 380K This set of plans and specifications must be kept on the job at all times and it is unlawful to make any changes or alterations from the same without written permission from the Building Inspection Division.

OTHER CHARGES SACRAMENTO CITY RACKS ALUM REDWOOD SPECIFICATION? TAR & GRAVEL FLAT ROOF RACKS ARBOR GROUND RACK TILE ROOF RACKS PATIO RACK HEATER REMOVAL & HAUL AWAY SYSTEM REMOVAL PIPE PANELS TRELLIS

COMMENTS TO CREW SYSTEM IS INTENTIONALLY UNDERSIZED BY (1) PANEL ** NO PRESITE REQUIRED

STATEMENT OF PERFORMANCE

Due to variations in weather and other environmental conditions surrounding a solar heating system, the specific performance of this system cannot be guaranteed; however, the design of this proposed system is expected to yield a nominal pool water temperature of degrees (F) from to without the use of supplementary heating.

CUSTOMER SIGNATURE

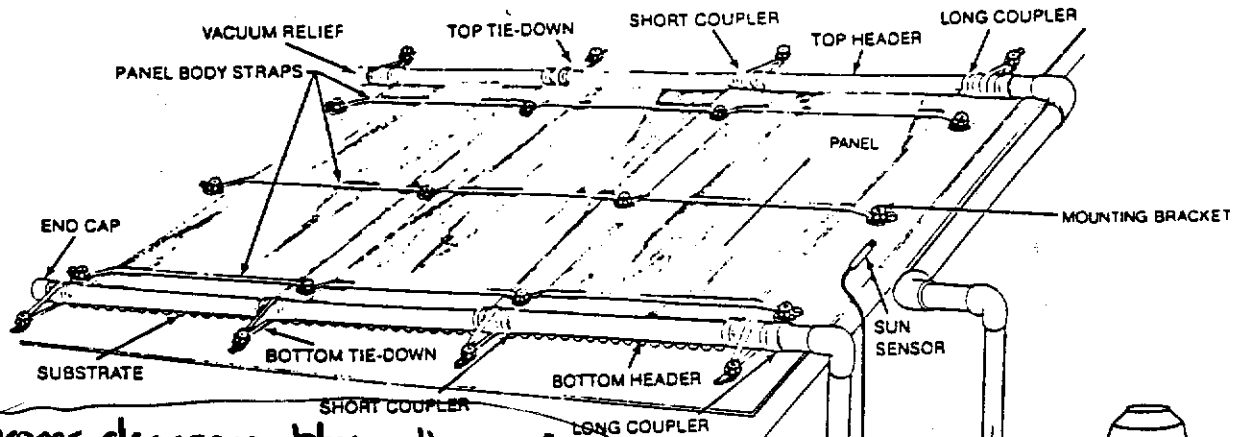

proper clearance btwn the roof and piping is req'd (1/2" min.)

Loading of the existing roof by the new solar panels is subject to field approval
ok 47

All equipment shall be properly anchored. Anchorage is subject to field approval
ok 47

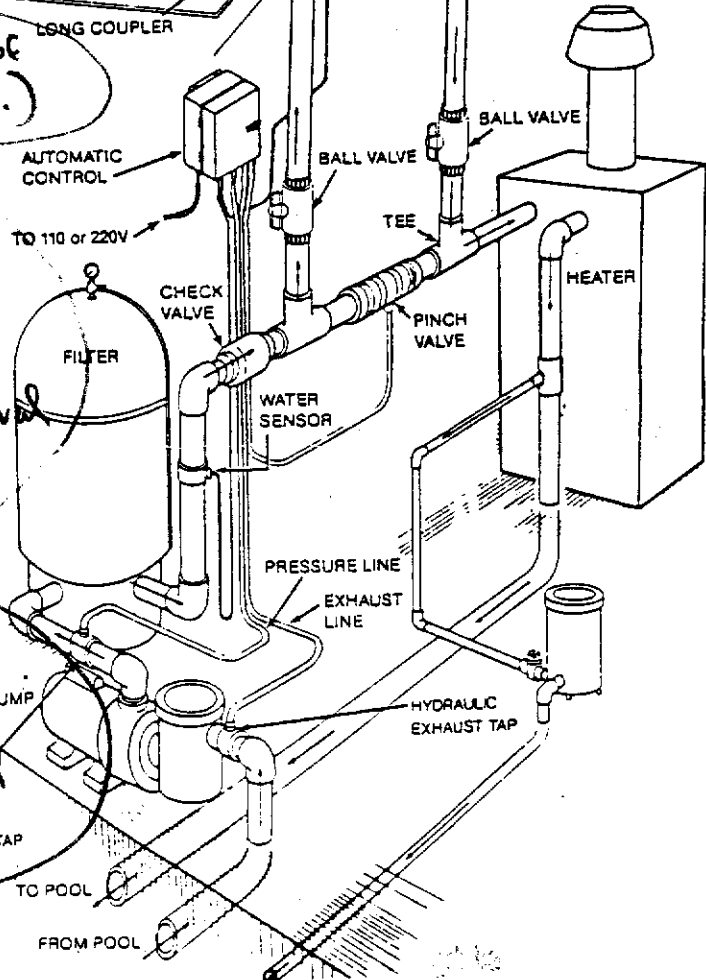

CONTENTS	
COMPONENT IDENTIFICATIONS	Page 2
BEFORE YOU START	Page 3
MOUNTING THE SOLAR COLLECTORS	Page 4
PANEL COUPLING ASSEMBLY	Page 6
PLUMBING MODIFICATIONS	Page 7
MODEL 600 CONTROL	Page 8
MODEL 300 CONTROL	Page 9
CHECK LIST AND TROUBLESHOOTING	Page 11

B Plancheck
G. Thomas
J. D. Costa

BRACKET INSTALLATION

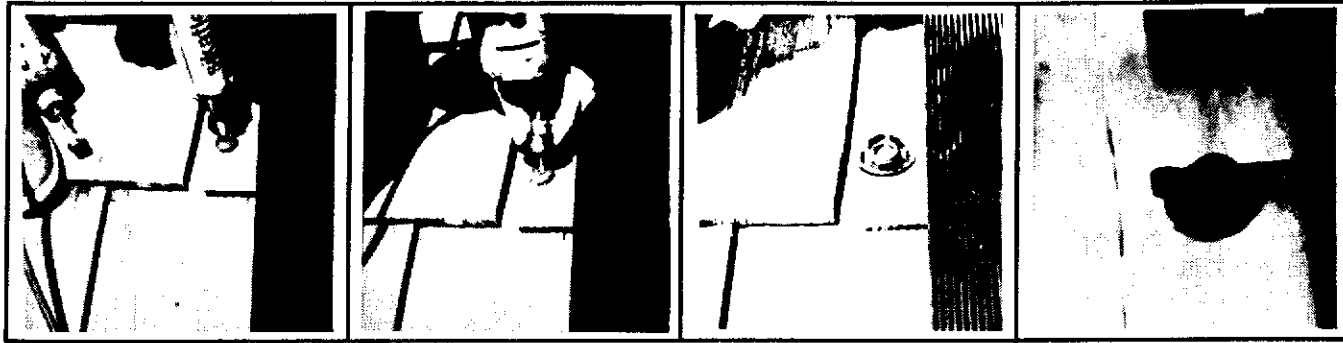

1. Locate bracket base on roofing above subroof or sheathing. (Do not attempt to attach brackets to roof material only!)
2. Mark and drill a pilot hole.
3. Inject the FAFCO recommended sealant into the pilot hole, being certain to leave enough on top of the hole so that a small amount will ooze out around the bracket when it is secured.
4. Put the lag screw into the bracket base and secure the bracket base to the roof.
5. Lay the panel strap through the bracket base. Panel straps can be put through single or doubled over.
6. Screw on a bracket cap and hand tighten. A 1/2" ratchet may be used to tighten the cap if desired.



SUBSTRATE

Substrate is a sheet of 2 1/2" corrugated 4 oz. fiberglass that is used as a protective measure and goes between the solar panel and mounting surface. It will provide the necessary support for the panels and protect the roof. Substrate is required on all roof types and shake or wooden shingle, tar and gravel, tile or cement shingle. Simply lay it under the panel.

BUILT UP ROOFING

A tar and gravel or tile roof requires special care. For further instructions contact your local distributor.

SEALING SEQUENCE

SPECIAL CARE AND ATTENTION SHOULD BE EXERCISED IN SEALING THE LAG SCREWS WHERE THEY PENETRATE THE PRIMARY ROOF. FOLLOW THE DIRECTIONS CAREFULLY.

TOP AND BOTTOM HEADER TIE-DOWN



Both the top and bottom ties are secured the same way. Use the webbed strap for the top ties and the stretchy vinyl strap for the bottom ties.

1. Pass the strap around the rubber coupler.
2. Mark a spot 4" to 7" from the header pipe of the panel.
3. Secure a mounting bracket at the spot you marked per the instructions above.
4. Lay both ends of the strap through the mounting bracket base and screw on a cap.

SOLAR EQUIPMENT LOADS ON A TRUSS ROOF

NOTE - ALL SOLAR EQUIPMENT MUST BE DESIGNED TO MEET THE FOLLOWING THREE REQUIREMENTS:

1. MAINTAIN THE WEATHER INTEGRITY OF ROOF
2. MUST BE SECURED FROM UPLIFT
3. DESIGN ROOF STRUCTURE TO SUPPORT ADDITIONAL LOAD OF UNIT ON ROOF

INSTALL CONTROL WIRE IN CONDUIT APPROVED FOR EXT. USE

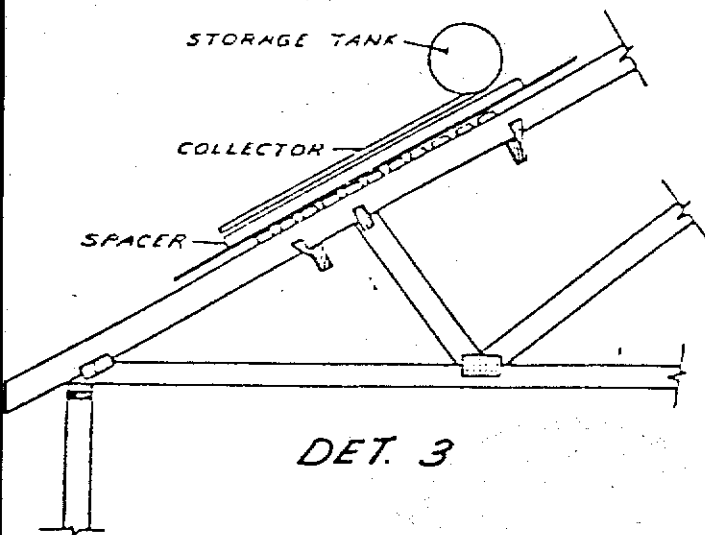
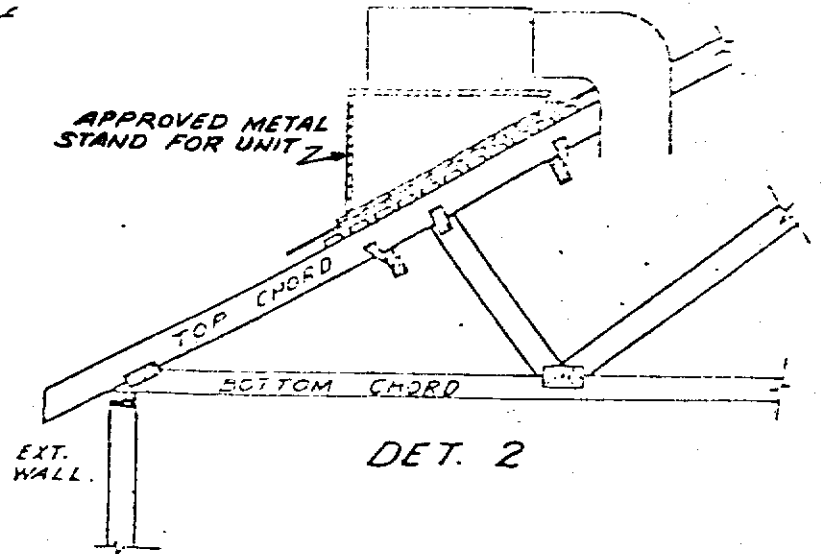
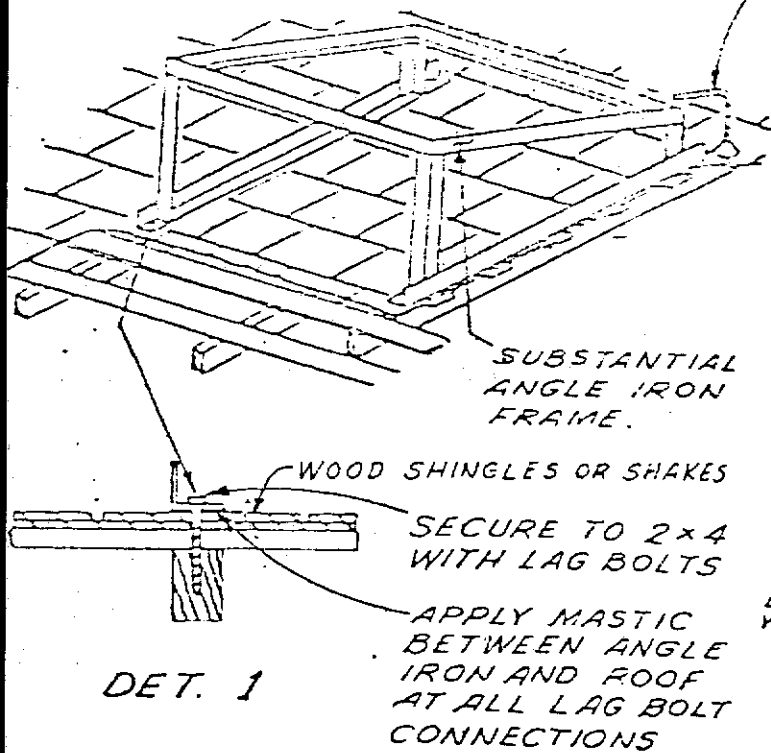

2x6 PURLINS TO SPAN MINIMUM OF 4 TRUSSES

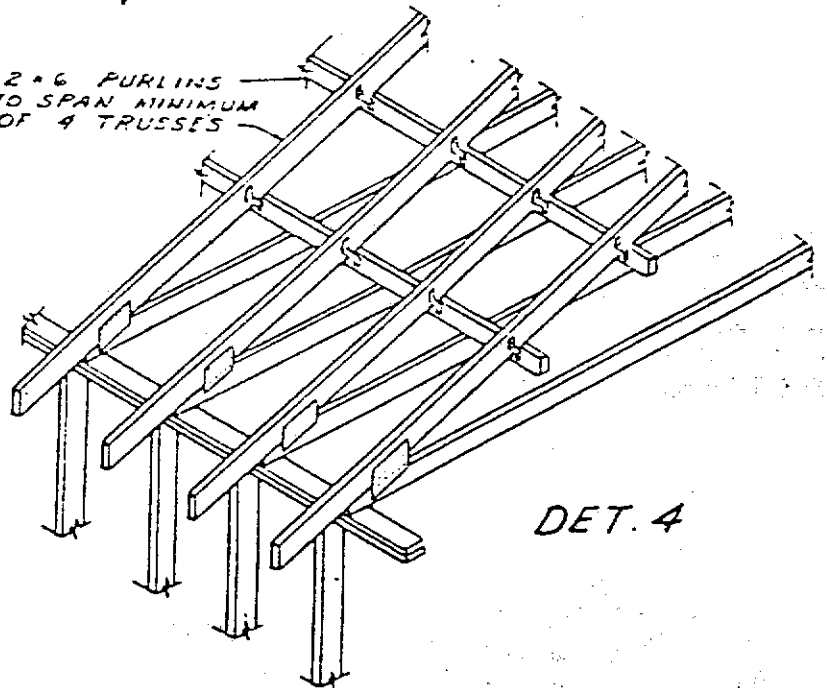

ALL PURLINS TO BE 2x6 STANDARD OR BETTER MATERIAL SECURED TO BOTTOM SIDE OF TOP CHORD OF TRUSS WITH APPROVED METAL CONNECTORS ON EACH SIDE OF RAFTERS. (SEE DETS 4, 5)

PURLINS MUST EXTEND ONE RAFTER SPACE BEYOND EQUIPMENT SUPPORTS BUT IN NO CASE LESS THAN A CONNECTION OF 4 TOP CHORDS (6' LONG)

NOTE # 1

ALL METAL STANDS OR SUPPORTS FOR MECHANICAL OR SOLAR EQUIPMENT TO BE INSULATED FROM COMPOSITION ROOFING MATERIAL W/MINIMUM OF 1x4 REDWOOD OR TREATED MATERIAL. (SEE DET. 1 ABOVE)

ADDED SUPPORT
UNDER METAL STAND
SUPPORTED BY 2x6
PURLIN.

LAG BOLT STAND
OR SUPPORT TO
ROOF STRUCTURE
NOTE: MAY NOT BE
SUPPORTED THRU
SHEATHING ONLY.

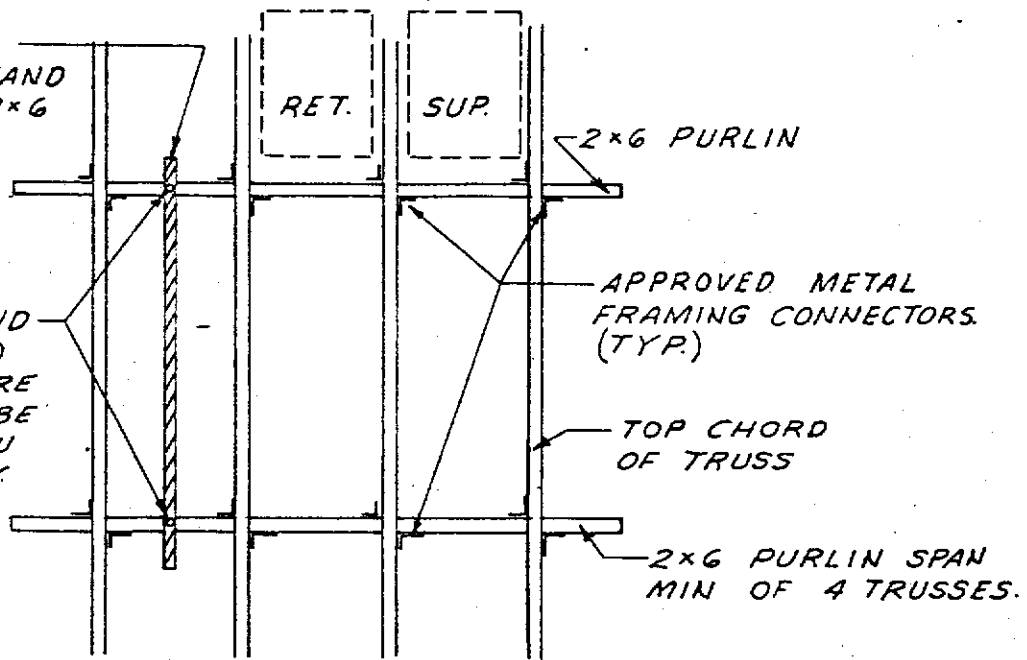

DET. 5

2x SUPPORTS FOR SOLAR PANELS W/OUT TANKS
MUST BE SECURED TO ROOF THRU THE RAFTER
OR BLOCKS INSTALLED BETWEEN RAFTERS.
(NOT PERMITTED THRU SHEATHING ONLY)

ALL SOLAR EQUIPMENT MUST
BE SUPPORTED 1/2" ABOVE
SURFACE OF ROOF OR BE
MADE AN INTEGRAL PART
OF THE ROOF AND
PROPERLY FLASHED.

NOTE: ADDITIONAL PURLINS
SUPPORTS NOT REQUIRED FOR
MOST PANELS W/OUT WATER TANKS

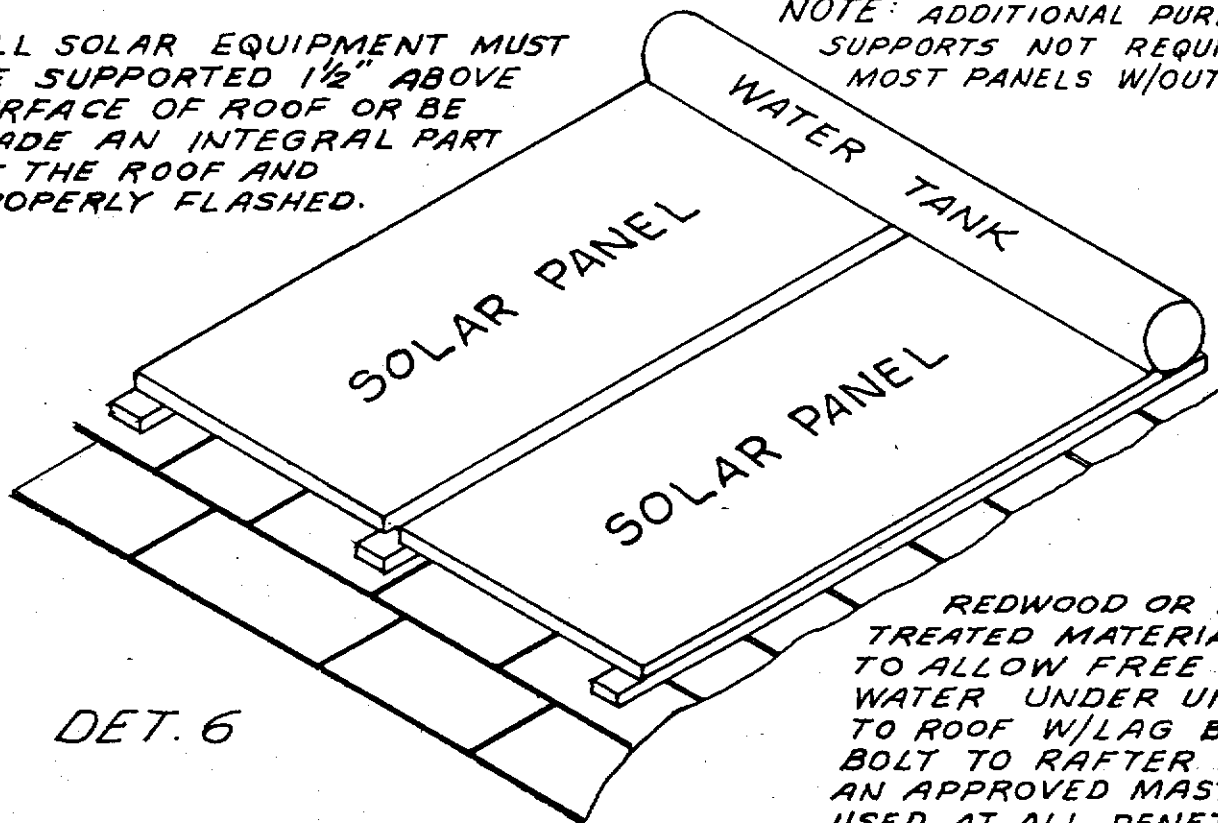

DET. 6

REDWOOD OR PRESSURE
TREATED MATERIAL 1/2" THICK
TO ALLOW FREE FLOW OF
WATER UNDER UNIT. SECURE
TO ROOF W/LAG BOLT, OR
BOLT TO RAFTER AND
AN APPROVED MASTIC
USED AT ALL PENETRATIONS.



To avoid unnecessary service calls...use this check list for your FAFCO System.

If There's No Power Light (300 Series Only)

1. Put Function Switch (A) on "On" Position...if still no light, check to see if circuit to auto control is powered.

If The System Does Not Appear To Be Heating The Pool

1. Is the Filter and Leaf Trap clean?
2. Is timer set 8-10 a.m. to 4-5 p.m., or for at least 8 hours operation during solar hours?
3. Have you been refilling the pool with cold water a lot lately?
4. Has weather been marginal?
5. Are the panels operating "cool" to the touch on a sunny day?
6. If night time temperatures are very low, are you using a pool blanket to retain the heat provided by the solar system during the day?

If There Are No Initial Bubbles

1. Make sure the pump is turned on and is working (if it does not go on, check fuse if it has one, and check the power to the pump).
2. (300 only) Place Function Switch (A) on Automatic Control in "On" position...it is possible that the system is not supposed to be working due to the fact that the pool temperature is already at Desired Temp, or there is not enough radiant heat available.
3. Check Isolation Valves (5) to make sure they are open.

If Tiny Champagne Bubbles Continue

...past the initial purging (3-5 minutes)...this may be an indication that the water circulation through the panels has been reduced to the point where the Vacuum Relief Valve (mounted in the end of the solar collector array) is admitting air either continuously or intermittently; therefore: check Pump and Leaf Trap for proper operation...be sure the pool filter and leaf trap is clean. It is possible that some small bubbles will always be discharged into the pool due to the particular characteristics of the system's normal operation. They do not affect the operation of the system nor impair the proper function of any other pool equipment.

Occasionally Check the Automatic Timer

...for your pool pump to see that the clock is set for the proper time. Power failures, adjustments for Daylight Saving Time, etc. will put it behind. It will be necessary to adjust the timer according to the season so that the Solar System will operate during the most beneficial hours of the day.

Pool Cleaner Timer

Special care must be taken when setting the timer for automatic pool cleaning equipment. Set your pool cleaning equipment timer to turn on after the solar system. Typically, operating hours between 12:00 and 8:00 a.m. or p.m. are acceptable. This precaution prevents air from entering and possibly damaging pool cleaning equipment during the startup of your solar system.

Your FAFCO Solar System

Thank you

Since 1969, our goal has been to design, test and produce a solar heating system that will let you get additional swimming pleasure from your pool. Keep this manual within easy reach and refer to it often.

What You can Expect From Your Solar System

As wonderful and abundant as solar energy is...it will not work miracles. And, with systems being installed in every part of the country varying widely in weather conditions...it is difficult to give performance temperatures here that would hold true in all areas. With these considerations in mind...and assuming you're having sunny weather and your system is on...you can expect it to:

1. heat the water 2°F-5°F every time it passes through the system.
2. raise your pool's temperature 5°F-15°F over a period of several days of good weather.
3. eliminate or significantly reduce the cost of operating your fossil fuel pool heater...but not totally replace it during the colder less sunny months (a nighttime pool cover will enhance #2 & 3. above).
4. give you years of trouble-free service even beyond the 10-year warranty.

System Specifications

ROOF MOUNTING SPACE:	Width— (number of panels x 51.5") + 24" Length—Panel length + 24"	
RACK SPACE:	Width— (number of panels x 51.5") + 2" Length—Panel length + 8"	
FLOW:	Recommended flow—4 gpm per panel (0.88 psi headloss) Maximum recommended flow—8 gpm per panel (3.53 psi headloss) Minimum recommended flow—3 gpm per panel (0.50 psi headloss)	
PANELS PER BANK: (Maximum)	12 panels single end feed 17 panels diagonal feed	
PRESSURE:	Normal Operating Pressure 0 to 15 psi	Minimum Intermittent Pressure 35 psi
80°F (27°C)		
CORROSION:	Non-corrosive	
WEIGHT: (4' x 10')	Without water—19 lbs. or 0.47 lbs./ft.2 Full of water—53 lbs. or 1.33 lbs./ft.2	

This manual is designed for residential use only. Commercial systems, or any other system in excess of 20 panels, require further engineering and design. Please contact your local FAFCO distributor.

Represented by

County of Sacramento

SOLAR INSTALLATION WORKSHEET

Pool/Spa

Domestic Hot Water

Space Heating

PLOT PLAN

Show Location of Collector(s), Storage Tank(s) and Control

DESIGN DATA

Collector MFG. FAFCO Model PROFILE

Dimensions: L. 12 x W. 4 x H. 1/4

Weight 21 lbs. Dry 73.3 lbs. Wet

Max. Live Load 1.33 lbs/ft

Heat Transfer (Fluid/Gas)

Certification IAPMO S-1889

Storage Tank MFG. N/A Size IAPMO No.

Control MFG. COMPOOL

Model LX-22 IAPMO No. S-1889

Circulator Pump MFG. Motor

Model IAPMO No.

Max. Flow Rate 8 GPM/SCPM

System Operating Pressure 0-15

System Operating Temp.: Hi. 95° F/Lo 40° F

ROOF DESIGN

Type Covering

Type Frame: Truss Conventional

Size of Frame Members 2 x 6 @ 2 o.c.

Clear Span. 10 Ft. Roof Pitch 4:12

Support Required: Yes No

ADDITIONAL INFORMATION

MFR. Installation Data Yes No

MFR. System Flow Diagram Yes No

MFR. Electrical Schematic Yes No

MFR. Test Instruction Yes No

System Certification(s) Yes No

Front Scale:

Owner: Telephone:

Address:

Location: Zip:

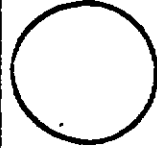

Indicate North

EW/CL 2-26-84

Contractor SIERRA SUN INDUSTRIES Co. Reg. No.

DIAGRAM INSTRUCTIONS

Draw location of house as situated on property in relation to pool and pool equipment pad. Indicate roof measurements and placement of solar collector panels.

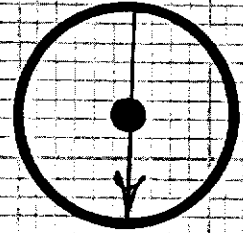

INDICATE SOUTH

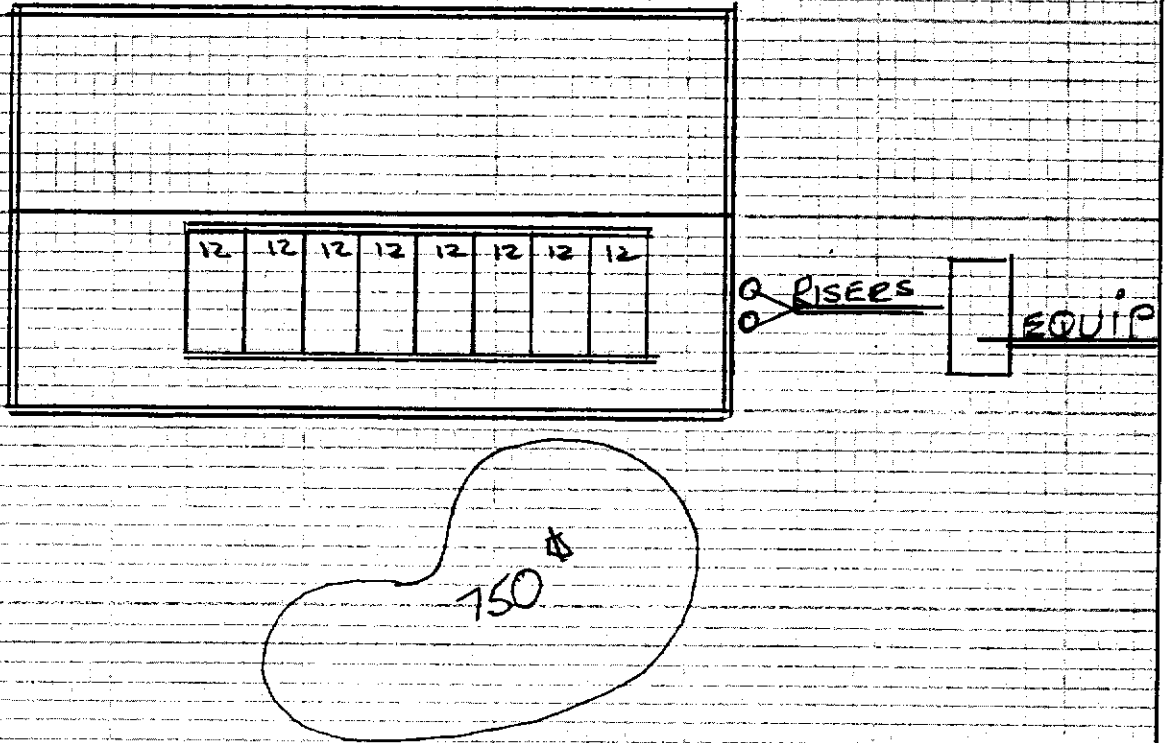

NEW POOL EQ SOLD

PUMP SIZE & TYPE _____ FILTER SIZE & TYPE _____

SWEEP TYPE _____ BOOSTER PUMP _____