

CITY OF SACRAMENTO
1231 I Street, Sacramento, CA 95814

Permit No: 0317502
Insp Area: 4
Thos Bros: 257-C5

Site Address: 5382 NICKMAN WY SAC
Parcel No: REGENCY PARK B LOT 40

Sub-Type: NSFR
Housing (Y/N): N

CONTRACTOR
PULTE HOME CORP.
985 SUN CITY LN.
LINCOLN CA. 95648

OWNER
PULTE HOME CORP.
985 SUN CITY LN.
LINCOLN CA. 95648

ARCHITECT

Nature of Work: MP2108 2 STORY 8 ROOM SFR

CONSTRUCTION LENDING AGENCY : I hereby affirm under penalty of perjury that there is a construction lending agency for the performance of the work for which this permit is issued (Sec. 3097, Civ. C).

Lender's Name _____ Lender's Address _____

LICENSED CONTRACTORS DECLARATION: I hereby affirm under penalty of perjury that I am licensed under provisions of Chapter 9 (commencing with section 7000) of Division 3 of the Business and Professions Code and my license is in full force and effect.

License Class B License Number 517593 Date 9/30/05 Contractor Signature RJ Hazlett

OWNER-BUILDER DECLARATION: I hereby affirm under penalty of perjury that I am exempt from the contractors License Law for the following reason (Sec. 7031.5, Business and Professions Code; any city or county which requires a permit to construct, alter, improve, demolish, or repair any structure, prior to its issuance, also requires the applicant for such permit to file a signed statement that he or she is licensed pursuant to the provisions of the Contractors License Law (Chapter 9 (commencing with Section 7000) of Division 8 of the Business and Professions Code) or that he or she is exempt therefrom and the basis for the alleged exemption. Any violation of Section 7031.5 by any applicant for a permit subjects the applicant to a civil penalty of not more than five hundred dollars (\$500.00);

_____, I, as a owner of the property, or my employees with wages as their sole compensation, will do the work, and the structure is not intended or offered for sale (Sec. 7044, Business and Professional Code: The Contractors License Law does not apply to an owner of property who builds or improves thereon, and who does such work himself or herself or through his/her own employees, provided that such improvements are not intended or offered for sale. If, however, the building or improvement is sold within one year of completion, the owner-builder will have the burden of proving that he/she did not build or improve for the purpose of sale.)

_____, I, as owner of the property, am exclusively contracting with licensed contractors to construct the project (Sec. 7044, Business and Professions Code: The Contractors License Law does not apply to an owner of property who builds or improves thereon, and who contracts for such projects with a contractor(s) licensed pursuant to the Contractors License Law).

_____, I am exempt under Sec. _____ B & PC for this reason: _____

Date _____ Owner Signature _____

PAID
CITY OF SACRAMENTO
DEC 02 2005

IN ISSUING THIS BUILDING PERMIT, the applicant represents, and the city relies on the representation of the applicant, that the applicant verified all measurements and locations shown on the application or accompanying drawings and that the improvement to be constructed does not violate any law or private agreement relating to permissible or prohibited locations for such improvements. This building permit does not authorize any illegal location of any improvement or the violation of any private agreement relating to location of improvements.

I certify that I have read this application and state that all information is correct. I agree to comply with all city and county ordinances and state laws relating to building construction and herby authorize representative(s) of this city to enter upon the abovementioned property for inspection purposes.

Date 11/24/03 Applicant/Agent Signature RJ Hazlett

WORKER'S COMPENSATION DECLARATION: I hereby affirm under penalty of perjury one of the following declarations:

_____, I have and will maintain a certificate of consent to self-insure for workers' compensation as provided for by Section 3700 of the Labor Code, for the performance of work for which the permit is issued.

_____, I have and will maintain workers' compensation insurance, as required by Section 3700 of the Labor Code, for the performance of the work for which this permit is issued. My workers' compensation insurance carrier and policy number are:

Carrier LIBERTY MUTUAL FIRE INS CO Policy Number WA269D004261012 Exp Date 06/01/2003

_____, (This section need not be completed if the permit is for \$100 or less) I certify that in the performance of the work for which this permit is issued, I shall not employ any person in any manner so as to become subject to the workers' compensation laws of California and agree that if I should become subject to the workers' compensation provisions of Section 3700 of the Labor Code, I shall forthwith comply with those provisions.

Date 11/24/03 Applicant Signature RJ Hazlett

WARNING: FAILURE TO SECURE WORKER'S COMPENSATION COVERAGE IS UNLAWFUL AND SHALL SUBJECT AN EMPLOYER TO CRIMINAL PENALTIES AND CIVIL FINES UP TO ONE HUNDRED THOUSAND DOLLARS (\$100,000) IN ADDITION TO THE COST OF COMPENSATION, DAMAGES AS PROVIDED FOR IN SECTION 3706 OF THE LABOR CODE, INTEREST AND ATTORNEY'S FEE.

THIS PERMIT SHALL EXPIRE BY LIMITATION IF WORK IS NOT COMMENCED WITHIN 180 DAYS.

SACRAMENTO BUILDING PERMIT APPLICATION

Project Address: 5382 Nickman Way Assessor Parcel# 201-0310-018-0000 - Master#
Lot Number: 40 Subdivision: Regency Park - Village B

OWNER INFORMATION:

Legal Property Owner: Pulte Home Corp. Phone # (916) 746-6153
Owner Address: 4196 Douglas Blvd. #100 City: Granite Bay State: CA Zip: 95746

CONTRACTOR INFORMATION:

Contractor: Pulte Home Corp. Lic.# 517593 Phone# (916) 746-6153 Fax # (916) 746-6144

PROJECT INFORMATION:

Land Use Zone R1A Occupancy Group R3 Construction Type VN Fed Code 1A
No. of Stories: 2 No. of Rooms: 8 Street Width: 41' R/W 30'
1st Floor Area 954 2nd Floor Area: 1154 Basement: n/a Roof Material: Tile

AREA IN SQUARE FOOT OF:

Dwelling/Living	<u>2108</u>
Garage Storage	<u>427</u>
Decks/Balconies	<u>n/a</u>
Carports	<u>n/a</u>

SCOPE OF WORK: Park Lane @ Regency Park - Plan # 3

- | | | |
|---|---|---|
| <input type="checkbox"/> Information Above Complete | <input type="checkbox"/> AR Flood Waiver Required | <input type="checkbox"/> Planning Approval |
| <input type="checkbox"/> Violation Files Checked | <input type="checkbox"/> Flood Elevation Certificate Required | <input type="checkbox"/> Design Review Approval |
| <input type="checkbox"/> Standard Setbacks | <input type="checkbox"/> Water Development Infill Area | <input type="checkbox"/> Special Fee Districts Apply: |
| <input type="checkbox"/> County Sewer | | |

****THE FOLLOWING MUST BE PROVIDED IN ORDER TO SUBMIT FOR PERMIT****

- 2 COMPLETE PLOT PLANS, LEGIBLE & DRAWN TO SCALE
 11 X 17 COPY OF FLOOR PLAN WITH FOLLOWING INFORMATION
- | | |
|-----------------------------|---------------------|
| a.) Assessors Parcel Number | c.) Owners Name |
| b.) New Floor Area | d.) Owner's Address |

0317502

COUNTY SANITATION DISTRICT 1
 SACRAMENTO REGIONAL COUNTY SANITATION DISTRICT
SEWER IMPACT FEE
 PERMIT AND CALCULATION

[Signature]
 11/26/03

APPLICATION NO. _____ BLDG PERMIT NO. **SWD2003-01061**
 GENERAL INFORMATION THIS PERMIT GOOD ONLY WHEN
 VALIDATED BY THE CASHIER

THIS PERMIT TO CONNECT EXPIRES
 ONE YEAR FROM DATE OF ISSUANCE

FEE CALCULATION		BUILDING USE	
INSPECTION		RESIDENTIAL	SF <input checked="" type="checkbox"/> MF <input type="checkbox"/>
CSD-1	1853		
SRCSD	5355		
CONSTRUCTION			
IN LIEU			
TOTAL FEE	7108		

APN: ~~19D1201-0310-012-0000~~ **201-0540-038**
 DESCRIPTION **Riverview Park M.B** LOT: **40**
 SUBDIVISION
 PROPERTY ADDRESS **5382 Nickman Way**
 OWNER **Pulte Home Corp**
 MAILING ADDRESS **414 Delgado Blvd St 10D**
 CITY-STATE-ZIP **Grant Bay, CA 95744** PHONE **(916) 746-6153**

ADDITIONAL FEES MAY BE DUE IF CHANGES IN USE INCREASE SEWER IMPACT
 APPLICANT SIGNATURE *[Signature]*
 CONSOLIDATED UTILITY BILLING USE ONLY

ACCT _____ INPUT _____ START _____
 INSPECTOR'S COPY

Certification of Compliance School District Development Fees

PART 1 To be completed by APPLICANT

Owner's Name & Address Full Home - 4110 S. Taylor Blvd. #100, Granite Bay, CA 95746
 Project Address 5382 Millman Way
 Parcel Number _____ Lot No. 40
 Subdivision Name SUNNYVALE PARK - VII B Number of Units 1
 Applicant's Signature & Title [Signature] DIRECTOR OF USE
 Date 11/27/02 Phone No. 916-744-1153

NOTICE TO APPLICANT: Pursuant to Government Code Section 66020(d), this will serve to notify you that the 90-day approval period in which you may protest the fees or other payment identified above will begin to run on the date in which the building or installation permit for this project is issued or on which they are paid to the district(s) or to another public entity authorized to collect them on behalf of the district(s), whichever is earlier.

PART 2 To be completed by BUILDING DEPARTMENT

Plan Identification Number _____
 Square Feet of Chargeable Building Area 2108
 Signature [Signature]
 Title City Planner
 Building Type (CHECK ONE)
 Residential
 Apartment/Condominium
 Commercial/Industrial
 Date 11/3/02

PART 3 To be completed by SCHOOL DISTRICTS

Grant Joint Union High School District
 District Certification No. 07-917
 EXEMPT _____
 Comments
RESIDENTIAL / APARTMENT / CONDOMINIUM
2108 Sq.Ft. x \$ 2,14 = \$ 4511.12
COMMERCIAL / INDUSTRIAL
 _____ Sq.Ft. x \$ _____ = \$ _____
 OTHER FEE: TYPE _____
 _____ Sq.Ft. x \$ _____ = \$ _____
 TOTAL FEES COLLECTED = \$ 4511.12

Robla Elementary School District
 District Certification No. _____
 EXEMPT _____
 Comments
RESIDENTIAL / APARTMENT / CONDOMINIUM
 _____ Sq.Ft. x \$ _____ = \$ _____
COMMERCIAL / INDUSTRIAL
 _____ Sq.Ft. x \$ _____ = \$ _____
 OTHER FEE: TYPE _____
 _____ Sq.Ft. x \$ _____ = \$ _____
 TOTAL FEES COLLECTED = \$ _____

This Certification covers only the amount of square footage indicated above. Any additions or corrections to the square footage for this project will require an amendment to the Certificate of Compliance.
 As the authorized school district official, I hereby certify that the requirements of Government Code Section 65995 and any other authorized requirements have been complied with by the above signed applicant.

GRANT	ROBLA
Authorized School District Official	
Signature <u>[Signature]</u> Title <u>Secretary</u> Date <u>11-29-03</u>	Signature _____ Title _____ Date _____

Original: Grant Joint Union High School District/
 Robla Elementary School District
 1st Copy: Building Department
 2nd Copy: Applicant

THIS PLOT PLAN IS NOT FOR SALES PURPOSES. THIS PLOT PLAN IS FOR THE PURPOSES OF INDICATING COMPLIANCE WITH ZONING SETBACKS, GENERAL DRAINAGE DIRECTION, AND APPROXIMATE UTILITY CONNECTION. ALL OTHER DATA SHOWN HEREON IS CONCEPTIONAL. THIS PLOT PLAN DOES NOT REFLECT AS-BUILT CONDITIONS, RETAINING WALLS ARE OPTIONAL AND MAY OR MAY NOT BE CONSTRUCTED.

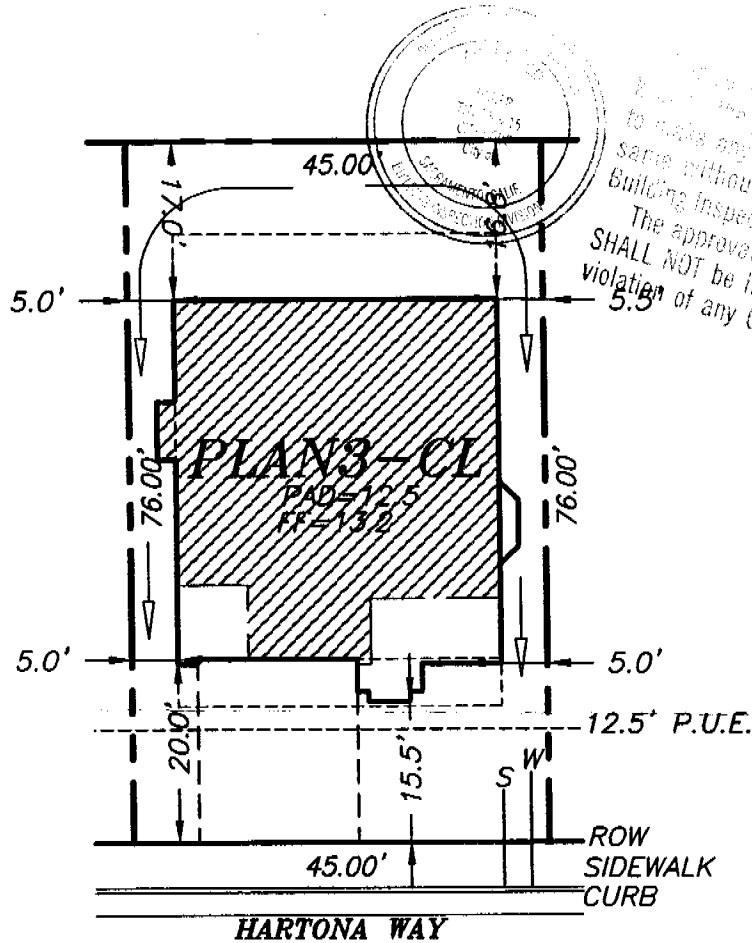

The approval of this plan and specification SHALL NOT be held to permit or approve the violation of any City Ordinance or State Law.

LEGEND

- > DRAINAGE FLOW
- ☐ PHONE / CABLE PEDESTAL
- ▲ TRANSFORMER
- [2] JUNCTION BOX
- ES ELECTRIC SERVICE
- SS SEWER CONNECTION
- WS WATER SERVICE
- STREET LIGHT
- FIRE HYDRANT
- 10"X12" VAULT



PULTE HOME CORPORATION
PARK LANE
AT REGENCY PARK
 CITY OF SACRAMENTO, CALIFORNIA

PLOT PLAN

5382 NICKMAN WAY

LOT AREA 3420 SQ.FT.

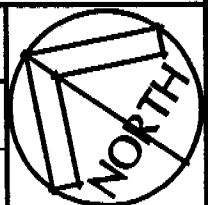

A.P.N.:

DATE: 10-15-03

SCALE: 1"=20'

UNIT: VILLAGE "B"

LOT NO.: 40

APPROVED:

OMEGA PRODUCTS INTERNATIONAL, INC.

DIAMOND WALL INSULATING STUCCO SYSTEM

JOB ADDRESS:

ICBO Report #4004

5382 NICKMAN WAY

LOT 40

Date of Job Completion _____

PLASTERING CONTRACTOR:

Name: Stellar Enterprises

Address: 29054 Goetz RD.

Telephone No: 909-244-0525

Contractor Number of Diamond Wall System 5026

This is to certify that the exterior coating system on the building exterior at the above address has been installed in accordance with the evaluation report specified above and the manufacturer's instructions.

Date

6/18

JR
Signature of authorized representative of
Plastering Contractor

This installation card must be presented to the building inspector after completion of work and before final inspection.

