

CITY OF SACRAMENTO
1231 I Street, Sacramento, CA 95814

Permit No: 0317372

Insp Area: 4

Thos Bros:

Sub-Type: NSFR

Housing (Y/N): N

Site Address: 5376 NICKMAN WY SAC

Parcel No: REGENCY PARK B LOT 41

CONTRACTOR

PULTE HOME CORP.
985 SUN CITY LN.
LINCOLN CA. 95648

OWNER

PULTE HOME CORP.
985 SUN CITY LN.
LINCOLN CA. 95648

ARCHITECT

Nature of Work: MP1685 2 STORY 8 ROOM SFR

CONSTRUCTION LENDING AGENCY : I hereby affirm under penalty of perjury that there is a construction lending agency for the performance of the work for which this permit is issued (Sec. 3097, Civ. C).

Lender's Name _____ Lender's Address _____

LICENSED CONTRACTORS DECLARATION: I hereby affirm under penalty of perjury that I am licensed under provisions of Chapter 9 (commencing with section 7000) of Division 3 of the Business and Professions Code and my license is in full force and effect.

License Class B License Number 517593 Date 9/30/05 Contractor Signature KJ Hazlett

OWNER-BUILDER DECLARATION: I hereby affirm under penalty of perjury that I am exempt from the contractors License Law for the following reason (Sec. 7031.5, Business and Professions Code; any city or county which requires a permit to construct, alter, improve, demolish, or repair any structure, prior to its issuance, also requires the applicant for such permit to file a signed statement that he or she is licensed pursuant to the provisions of the Contractors License Law (Chapter 9 (commencing with Section 7000) of Division 8 of the Business and Professions Code) or that he or she is exempt therefrom and the basis for the alleged exemption. Any violation of Section 7031.5 by any applicant for a permit subjects the applicant to a civil penalty of not more than five hundred dollars (\$500.00);

_____, I, as a owner of the property, or my employees with wages as their sole compensation, will do the work, and the structure is not intended or offered for sale (Sec. 7044, Business and Professional Code: The Contractors License Law does not apply to an owner of property who builds or improves thereon, and who does such work himself or herself or through his/her own employees, provided that such improvements are not intended or offered for sale. If, however, the building or improvement is sold within one year of completion, the owner-builder will have the burden of proving that he/she did not build or improve for the purpose of sale.)

_____, I, as owner of the property, am exclusively contracting with licensed contractors to construct the project (Sec. 7044, Business and Professions Code: The Contractors License Law does not apply to an owner of property who builds or improves thereon, and who contracts for such projects with a contractor(s) licensed pursuant to the Contractors License Law).

I am exempt under Sec. _____ B & PC for this reason: _____

Date _____ Owner Signature _____

PAID
CITY OF SACRAMENTO
DEC 02 2003
CITY PERMIT CENTER

IN ISSUING THIS BUILDING PERMIT, the applicant represents, and the city relies on the representation of the applicant, that the applicant verified all measurements and locations shown on the application or accompanying drawings and that the improvement to be constructed does not violate any law or private agreement relating to permissible or prohibited locations for such improvements. This building permit does not authorize any illegal location of any improvement or the violation of any private agreement relating to location of improvements.

I certify that I have read this application and state that all information is correct. I agree to comply with all city and county ordinances and state laws relating to building construction and hereby authorize representative(s) of this city to enter upon the abovementioned property for inspection purposes.

Date 11/24/03 Applicant/Agent Signature KJ Hazlett

WORKER'S COMPENSATION DECLARATION: I hereby affirm under penalty of perjury one of the following declarations:

_____, I have and will maintain a certificate of consent to self-insure for workers' compensation as provided for by Section 3700 of the Labor Code, for the performance of work for which the permit is issued.

_____, I have and will maintain workers' compensation insurance, as required by Section 3700 of the Labor Code, for the performance of the work for which this permit is issued. My workers' compensation insurance carrier and policy number are:

Carrier LIBERTY MUTUAL FIRE INS CO Policy Number WA269D004261012 Exp Date 06/01/2003

_____, (This section need not be completed if the permit is for \$100 or less) I certify that in the performance of the work for which this permit is issued, I shall not employ any person in any manner so as to become subject to the workers' compensation laws of California and agree that if I should become subject to the workers' compensation provisions of Section 3700 of the Labor Code, I shall forthwith comply with those provisions.

Date 11/24/03 Applicant Signature KJ Hazlett

WARNING: FAILURE TO SECURE WORKER'S COMPENSATION COVERAGE IS UNLAWFUL AND SHALL SUBJECT AN EMPLOYER TO CRIMINAL PENALTIES AND CIVIL FINES UP TO ONE HUNDRED THOUSAND DOLLARS (\$100,000) IN ADDITION TO THE COST OF COMPENSATION, DAMAGES AS PROVIDED FOR IN SECTION 3706 OF THE LABOR CODE, INTEREST AND ATTORNEY'S FEE.

THIS PERMIT SHALL EXPIRE BY LIMITATION IF WORK IS NOT COMMENCED WITHIN 180 DAYS.

SACRAMENTO BUILDING PERMIT APPLICATION

Project Address: 5376 Nickman Way Assessor Parcel# 201-0310-018-0000 - Master#
Lot Number: 41 Subdivision: Regency Park - Village B

OWNER INFORMATION:

Legal Property Owner: Pulte Home Corp. Phone #: (916) 746-6153
Owner Address: 4196 Douglas Blvd. #100 City: Granite Bay State: CA Zip: 95746

CONTRACTOR INFORMATION:

Contractor: Pulte Home Corp. Lic.# 517593 Phone# (916) 746-6153 Fax # (916) 746-6144

PROJECT INFORMATION:

Land Use Zone: R1A Occupancy Group: R3 Construction Type: VN Fed Code: 1A
No. of Stories: 2 No. of Rooms: 7 Street Width: 41' R/W 30'
1st Floor Area: 917 2nd Floor Area: 768 Basement: n/a Roof Material: Tile

AREA IN SQUARE FOOT OF:

Dwelling/Living 1685
Garage Storage 424
Decks/Balconies n/a
Carports n/a

SCOPE OF WORK: Park Lane @ Regency Park - Plan # 1

- Information Above Complete AR Flood Waiver Required Planning Approval
Violation Files Checked Flood Elevation Certificate Required Design Review Approval
Standard Setbacks Water Development Infill Area Special Fee Districts Apply:
County Sewer

THE FOLLOWING MUST BE PROVIDED IN ORDER TO SUBMIT FOR PERMIT

- 2 COMPLETE PLOT PLANS, LEGIBLE & DRAWN TO SCALE
11 X 17 COPY OF FLOOR PLAN WITH FOLLOWING INFORMATION
a.) Assessors Parcel Number c.) Owners Name
b.) New Floor Area d.) Owner's Address

0317372

COUNTY SANITATION DISTRICT 1
SACRAMENTO REGIONAL COUNTY SANITATION DISTRICT
SEWER IMPACT FEE
 PERMIT AND CALCULATION 11/20/03

APPLICATION NO: _____ BLDG PERMIT NO: **SW 12003 - 01061**
 GENERAL INFORMATION THIS PERMIT GOOD ONLY WHEN VALIDATED BY THE CASHIER

THIS PERMIT TO CONNECT EXPIRES
 ONE YEAR FROM DATE OF ISSUANCE

FEE CALCULATION		BUILDING USE	
INSPECTION		RESIDENTIAL	SF <input checked="" type="checkbox"/> MF <input type="checkbox"/>
CSD-1	1853	COMMERCIAL USE	
SRCSD	5255		
CONSTRUCTION			
INLIEU			
TOTAL FEE	7108		

APN: ~~115D-0301-0310-018-0000~~ **201-0540-038**
 DESCRIPTION/ SUBDIVISION: **Regency Park WLB LOT 41**
 PROPERTY ADDRESS: **5346 Nickman Way**
 OWNER: **Pulte Home Corp.**
 MAILING ADDRESS: **494 Douglas Blvd, Ste 100**
 CITY-STATE-ZIP: **Grant Bay, CA 95744** PHONE: **(916) 744-6153**
 ADDITIONAL FEES MAY BE DUE IF CHANGES IN USE INCREASE SEWER IMPACT.

APPLICANT SIGNATURE: *[Signature]*
 CONSOLIDATED UTILITY BILLING USE ONLY

ACCT: _____ INPUT: _____ START: _____

Certification of Compliance School District Development Fees

PART 1 To be completed by APPLICANT

Owner's Name & Address 1016 TOMES ROAD, FORTY-SEVEN, FORT WORTH, TEXAS 76116
 Project Address 5376 NEILMAN WAY
 Parcel Number _____ Lot No. 41
 Subdivision Name SUNNYVALE #1 & 2 Number of Units 1
 Applicant's Signature & Title [Signature]
 Date 11/24/03 Phone No. (817) 746-1158

NOTICE TO APPLICANT: Pursuant to Government Code Section 66020(d), this will serve to notify you that the 90-day approval period in which you may protest the fees or other payment identified above will begin to run on the date in which the building or installation permit for this project is issued or on which they are paid to the district(s) or to another public entity authorized to collect them on behalf of the district(s), whichever is earlier.

PART 2 To be completed by BUILDING DEPARTMENT

Plan Identification Number _____ Building Type (CHECK ONE)
 Square Feet of Chargeable Building Area 1685 Residential
 Signature [Signature] Apartment/Condominium
 Title Building Dept Commercial/Industrial
 Date 11/24/03

PART 3 To be completed by SCHOOL DISTRICTS

Grant Joint Union High School District
 District Certification No. 011-963
 EXEMPT _____
 Comments _____
RESIDENTIAL / APARTMENT / CONDOMINIUM
1685 Sq.Ft. x \$ 2.11 = \$ 3605.96
COMMERCIAL / INDUSTRIAL
 _____ Sq.Ft. x \$ _____ = \$ _____
 OTHER FEE: TYPE _____
 _____ Sq.Ft. x \$ _____ = \$ _____
 TOTAL FEES COLLECTED = \$ 3605.96

Robla Elementary School District
 District Certification No. _____
 EXEMPT _____
 Comments _____
RESIDENTIAL / APARTMENT / CONDOMINIUM
 _____ Sq.Ft. x \$ _____ = \$ _____
COMMERCIAL / INDUSTRIAL
 _____ Sq.Ft. x \$ _____ = \$ _____
 OTHER FEE: TYPE _____
 _____ Sq.Ft. x \$ _____ = \$ _____
 TOTAL FEES COLLECTED = \$ _____

This Certification covers only the amount of square footage indicated above. Any additions or corrections to the square footage for this project will require an amendment to the Certificate of Compliance.
 As the authorized school district official, I hereby certify that the requirements of Government Code Section 65995 and any other authorized requirements have been complied with by the above signed applicant.

GRANT	ROBLA
Authorized School District Official	
Signature <u>[Signature]</u> Title <u>Secretary</u> Date <u>11-24-03</u>	Signature _____ Title _____ Date _____

THIS PLOT PLAN IS NOT FOR SALES PURPOSES. THIS PLOT PLAN IS FOR THE PURPOSES OF INDICATING COMPLIANCE WITH ZONING SETBACKS, GENERAL DRAINAGE DIRECTION, AND APPROXIMATE UTILITY CONNECTION. ALL OTHER DATA SHOWN HEREON IS CONCEPTUAL. THIS PLOT PLAN DOES NOT REFLECT AS-BUILT CONDITIONS, RETAINING WALLS ARE OPTIONAL AND MAY OR MAY NOT BE CONSTRUCTED.

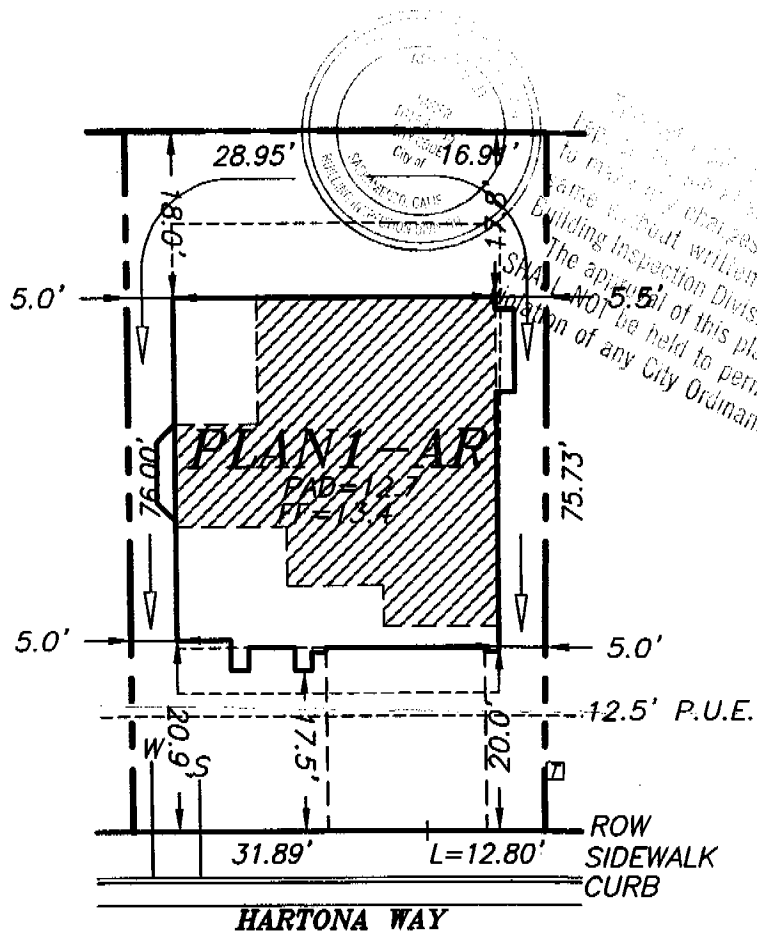

LEGEND

- ← DRAINAGE FLOW
- PHONE / CABLE PEDESTAL
- ▲ TRANSFORMER
- [2] JUNCTION BOX
- ES ELECTRIC SERVICE
- SS SEWER CONNECTION
- WS WATER SERVICE
- STREET LIGHT
- FIRE HYDRANT
- 10"X12" VAULT



PULTE HOME CORPORATION
PARK LANE
AT REGENCY PARK
 CITY OF SACRAMENTO, CALIFORNIA

PLOT PLAN

5376 NICKMAN WAY
 LOT AREA 3437 SQ.FT.

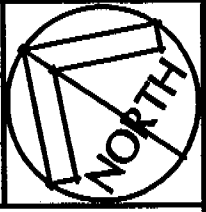

A.P.N.:

DATE: 10-15-03 SCALE: 1"=20' UNIT: VILLAGE "B" LOT NO.: 41 APPROVED:

LOT1.dwg Oct 24, 2003 - 8:41am

INSULATION CERTIFICATE

0317372

THIS IS TO CERTIFY THAT INSULATION HAS BEEN INSTALLED IN CONFORMANCE WITH THE CURRENT ENERGY REGULATIONS, CALIFORNIA ADMINISTRATION CODE, TITLE 24, STATE OF CALIFORNIA, IN THE BUILDING LOCATED AT:

5376 NICKMAN

SITE ADDRESS LOT 4101 PARK LANE SACRAMENTO CA
NUMBER CITY STATE

CEILING:

BLOW: MANUFACTURER GREEN FIBER THICKNESS 10.3" R/VALUE 38
SQUARE FEET 853 #BAGS/LBS PER BAGS 35

BATTS: MANUFACTURER JOHNS MANVILLE THICKNESS 19" R/VALUE 38
JOHNS MANVILLE

EXTERIOR WALLS:

MANUFACTURER JOHNS MANVILLE THICKNESS 3.5" R/VALUE 13
JOHNS MANVILLE

FLOOR INSULATION:

MANUFACTURER JOHNS MANVILLE THICKNESS 6.5" R/VALUE 19
JOHNS MANVILLE

AIR INFILTRATION: (TITLE 24)

YES XXX NO

OTHER: _____

GENERAL CONTRACTOR: PULTE HOMES LICENSE # _____

BY: _____ TITLE _____ DATE _____

INSULATION CONTRACTOR: WESTERN INSULATION LP LICENSE # 794484

BY: *Becky Gutierrez* TITLE AUTH. AGENT DATE 6/13/04
BECKY GUTIERREZ

OMEGA PRODUCTS INTERNATIONAL, INC.

DIAMOND WALL INSULATING STUCCO SYSTEM

JOB ADDRESS:

ICBO Report #4004

5376 Nickman way
Sacramento CA 95835

Date of Job Completion 6/24/04

PLASTERING CONTRACTOR:

Name: Stellar Enterprises

Address: 29054 Goetz RD.

Telephone No: 909-244-0525

Contractor Number of Diamond Wall System 5026

This is to certify that the exterior coating system on the building exterior at the above address has been installed in accordance with the evaluation report specified above and the manufacturer's instructions.

6/21/04
Date

JR
Signature of authorized representative of
Plastering Contractor

This installation card must be presented to the building inspector after completion of work and before final inspection.