

**CITY OF SACRAMENTO**  
1231 I Street, Sacramento, CA 95814

**Permit No: 9712303**  
**Insp Area: 4**

**Site Address: 1689 ARDEN WY SAC**

Parcel No: 2770160071

CHINA INN

Sub-Type: REM

Housing (Y/N): N

**CONTRACTOR**

PSD INC.  
9602 VENICE BL  
CULVER CITY CA 90232  
Phone: 310-559-3901

**OWNER**

ARDEN FAIR ASSOCIATES  
1689 ARDEN WAY #1167  
SACRAMENTO CA 95815  
Phone:

**ARCHITECT**

Phone:

**Nature of Work: REMODEL**

**CONSTRUCTION LENDING AGENCY:** I hereby affirm under penalty of perjury that there is a construction lending agency for the performance of the work for which this permit is issued (Sec. 3097, Civ. C).

Lender's Name \_\_\_\_\_ Lender's Address \_\_\_\_\_

**LICENSED CONTRACTORS DECLARATION:** I hereby affirm under penalty of perjury that I am licensed under provisions of Chapter 9 (commencing with section 7000) of Division 3 of the Business and Professions Code and my license is in full force and effect.

License Class \_\_\_\_\_ License Number 446702 Date \_\_\_\_\_ Contractor Signature For PSD Buynt HCO

**OWNER-BUILDER DECLARATION:** I hereby affirm under penalty of perjury that I am exempt from the contractors License Law for the following reason (Sec. 7031.5, Business and Professions Code; any city or county which requires a permit to construct, alter, improve, demolish, or repair any structure, prior to its issuance, also requires the applicant for such permit to file a signed statement that he or she is licensed pursuant to the provisions of the Contractors License Law (Chapter 9 (commencing with Section 7000) of Division 8 of the Business and Professions Code) or that he or she is exempt therefrom and the basis for the alleged exemption. Any violation of Section 7031.5 by any applicant for a permit subjects the applicant to a civil penalty of not more than five hundred dollars (\$500.00);

\_\_\_\_ I, as a owner of the property, or my employees with wages as their sole compensation, will do the work, and the structure is not intended or offered for sale (Sec. 7044, Business and Professional Code: The Contractors Law does not apply to an owner of property who builds or improves thereon, and who does such work himself or herself or through his or her own employees, provided that such improvements are not intended or offered for sale. If, however, the building or improvement is sold within one year of completion, the owner-builder will have the burden of proving that he or she did not build or improve for the purpose of sale.)

\_\_\_\_ I, as owner of the property, am exclusively contracting with licensed contractors to construct the project (Sec. 7044, Business and Professions Code: The contractors License Law does not apply to an owner of property who builds or improves thereon, and who contracts for such projects with a contractor(s) licensed pursuant to the Contractors License Law).

\_\_\_\_ I am exempt under Sec. \_\_\_\_\_ B & PC for this reason: \_\_\_\_\_

Date \_\_\_\_\_ Owner Signature \_\_\_\_\_

**IN ISSUING THIS BUILDING PERMIT,** the applicant represents, and the city relies on the representation of the applicant, that the applicant verified all measurements and locations shown on the application or accompanying drawings and that the improvement to be constructed does not violate any law or private agreement relating to permissible or prohibited locations for such improvements. This building permit does not authorize any illegal location of any improvement or the violation of any private agreement relating to location of improvements.

Date 3-10-09 Applicant/Agent Signature Buynt HCO

**WORKER'S COMPENSATION DECLARATION:** I hereby affirm under penalty of perjury one of the following declarations:

\_\_\_\_ I have and will maintain a certificate of consent to self-insure for workers' compensation as provided for by Section 3700 of the Labor Code, for the performance of work for which the permit is issued.

\_\_\_\_ I have and will maintain workers' compensation insurance, as required by Section 3700 of the Labor Code, for the performance of the work for which this permit is issued. My workers' compensation insurance carrier and policy number are:

Carrier Zenith Ins. Co. Policy Number 2040116003  
7/11/98

\_\_\_\_ (This section need not be completed if the permit is for \$100 or less) I certify that in the performance of the work for which this permit is issued, I shall not employ any person in any manner so as to become subject to the workers' compensation laws of California and agree that if I should become subject to the workers' compensation provisions of Section 3700 of the Labor Code, I shall forthwith comply with those provisions.

Date 3-10-09 Applicant Signature Buynt HCO

**WARNING: FAILURE TO SECURE WORKER'S COMPENSATION COVERAGE IS UNLAWFUL AND SHALL SUBJECT AN EMPLOYER TO CRIMINAL PENALTIES AND CIVIL FINES UP TO ONE HUNDRED THOUSAND DOLLARS (\$100,000) IN ADDITION TO THE COST OF COMPENSATION, DAMAGES AS PROVIDED FOR IN SECTION 3706 OF THE LABOR CODE, INTEREST AND ATTORNEY'S FEE.**

CITY OF SACRAMENTO  
P.D. 91  
Oct 03 1997

**THIS PERMIT SHALL EXPIRE BY LIMITATION IF WORK IS NOT COMMENCED WITHIN 180 DAYS.**

9712303

CITY OF SACRAMENTO  
APPLICATION FOR BUILDING PERMIT  
DEPARTMENT OF PLANNING AND DEVELOPMENT  
BUILDING INSPECTION DIVISION

1231 I Street, Room 200  
Sacramento, CA 95814  
(916) 264-7619 FAX 264-7046

ADDRESS 1689 ARDEN WAYS P.C. # 5384  
 PARCEL # \_\_\_\_\_ SUITE # 202  
AREA # 4C

CONTACT  
NAME SAT. GARE  LICENSED CONTRACTOR  
ADDRESS ACAR STUDIO NAME PSD INC.  
1404 2RD ST. PROMENADE ADDRESS 9602 VENICE BLVD.  
SUITE 201 ZIP MONICA CA 94041 ZIP 90232  
PHONE (916) 393-0625 FAX: (916) 393-7692 PHONE (916) 559-3901

ARCH./ENG. Fax ✓  OWNER/TENANT CLAUDE ALEXANDRE  
NAME SAME NAME CHINA INN  
ADDRESS \_\_\_\_\_ ADDRESS 2807 ORLEON CT. # F6  
ZIP \_\_\_\_\_ TURKANCE CA ZIP 90503  
PHONE \_\_\_\_\_ PHONE \_\_\_\_\_

WILL THE PERMITEE HAVE ANY EMPLOYEE'S ON THE JOBSITE?  YES  NO  
 NATURE OF WORK IN DETAIL: FAST FOOD RESTAURANT  
REMODEL - ARDEN FAIR MALL

D.B.A. CHINA INN  VALUATION 80,000  
BELOW THIS LINE FOR BLDG. DEPT. USE ONLY

FLOOD STATUS \_\_\_\_\_  S.C.A.T. \_\_\_\_\_

JOB DESCR. BLDG SHEL APT II(-) REM(✓) SW FIRE ADD OTH  
INSP. DISCIPLINES  BLDG  MECH  PLUMB  ELEC  SITE  FIRE

# OF STORIES	AREA 1ST FL.	TOTAL AREA	USE ZONE	OCCUP. GROUP	CONST. TYPE	FIRE SPRINK.	FED. CODE	VIO. FILE
B	(L)	(P)	(M)	(E)	(P)	Yes	18	
	JT	BD	BD	G-M		S	D	R

COMMENTS: Provide Health Dept. Plans  
Provide Heitman approved plans  
→ changes on this will be \$77.00 per hr

1032-68

WICKETS Comp Policy #  
COMPANY

EXP. DATE

RECEIPT  
 ENVIRONMENTAL MANAGEMENT DEPARTMENT  
 ENVIRONMENTAL HEALTH DIVISION

RECEIVED FROM: CHINA INN REST. INC. DATE: 8/12/97  
 ADDRESS: 17625 FABRICA WY., CERRITOS, CA 90703  
 AMOUNT RECEIVED: \$ 707.00 CHECK NO.: 1467 CASH   
 FACILITY NAME: CHINA INN  
 FAC. ADDRESS: 1689 ARDEN WY, S.P. 2022, S.A.C.

- DEPT 33 ENVIR. HLTH \$707.00  
 - TRN 345428 08/12/97  
 - RECEIPT 605835 C#1 \$707.00

REVENUE DESCRIPTION: (KEY 33)  
 PLAN CHECK - FOOD  
 PLAN CHECK - POOLS  
 PUBLIC POOL FEE (CONSTRUCTION INSPECTIONS)  
 PLAN CHECK - NOISE

INDEX	REV. DETAIL	PCA	AMOUNT
6202	8817	32142	\$ 707.00
6202	8818	32142	\$
6202	8710	32131	\$
6202	8823	32233	\$

SIGNATURE: Allen Maitza  
 W:\DATA\FORMS\EH\DHRS.FRM White - Cashier Yellow - Customer Pink - Environmental Management Department

OWNER-BUILDER VERIFICATION

ATTENTION PROPERTY OWNER

An owner-builder building permit has been applied for in your name and bearing your signature.

Please complete and return this information in the envelope provided at your earliest opportunity to avoid unnecessary delay in processing and issuing your building permit. No building permit will be issued until this verification is received.

1. I personally plan to provide the major labor and materials for construction of the proposed improvement (yes or no) NO

2. I (~~have~~ have not) HAVE signed an application for a building permit for the proposed work.

3. I have contracted with the following person (firm) to provide the proposed construction:

Name WAZELAN'S HEATING & A/C Address 3633 HOMESIDE AVE.  
City SACRAMENTO, CA 95608 Telephone 944-7868  
Contractors License No. 536539

4. I plan to provide portions of the work, but I have hired the following person to coordinate, supervise, and provide the major work.

Name \_\_\_\_\_ Address \_\_\_\_\_  
City \_\_\_\_\_ Telephone \_\_\_\_\_  
Contractors License No. \_\_\_\_\_

5. I will provide some of the work but I have contracted (hired) the following to provide the work indicated:

Name	Address	Phone	Type of Work

Signed Jullis

Job Address 1617-26th ST. SACRAMENTO Date 21 OCT 97

Permit No.: \_\_\_\_\_



GASOLINE SOLD? YES \_\_\_ NO

IF YES, FORWARD APPLICATION TO HMD

OFFICIAL USE ONLY

COUNTY OF SACRAMENTO  
ENVIRONMENTAL MANAGEMENT DEPARTMENT  
ENVIRONMENTAL HEALTH DIVISION  
8475 JACKSON ROAD, STE 240, SACRAMENTO, CA 95826 - PH 386-7682

BILL BY ASU CT # 55  
EMD RECEIPT # \_\_\_\_\_  
TOTAL FEE N/A  
DATE PAID \_\_\_\_\_

APPLICATION FOR PERMIT TO OPERATE  
(PLEASE PRINT)

- OWNER(S) OF BUSINESS CHINA INN RESTAURANTS, INC. (310) PH 787-0664
- OWNER'S ADDRESS 2807 OREGON COURT F6-7 CITY TORRANCE STATE CA ZIP 90503
- BILLING ADDRESS (if different from #2) Same
- NAME OF FACILITY/BUSINESS CHINA INN
- FACILITY ADDRESS 1689 ARDEN WAY #2022 Sacramento CA 95818 PH (916) 920-09
- FACILITY MAILING ADDRESS (if different from #5) Same as #2 above
- IF CORPORATION, LIST ALL OFFICERS TONY LIN, Pres.
- OWNER'S I.D.: SOC. SEC. NO/ FED TAX I.D. 33-0685897 CDL# N8089421
- DOES THIS ESTABLISHMENT HAVE A SEMI-FROZEN (SOFT SERVE) PROCESSING MACHINE? Yes  No
- IF FOOD FESTIVAL, EVENT NAME & DATES \_\_\_\_\_

Application is hereby made for HEALTH PERMIT to operate the following type(s) of facility:

TYPE	FEE	P/E CODE	TYPE	FEE	P/E CODE
<input checked="" type="checkbox"/> RESTAURANT	\$340.00	1622	<input type="checkbox"/> OPTION A		
<input type="checkbox"/> BAR	217.00	1620	TEMP FOOD FAC (FD PREP)	\$146.00 ea.	1661
<input type="checkbox"/> RESTAURANT W/BAR	490.00	1621	TEMP FOOD FAC (PKG FOOD)	73.00 ea.	1660
<input type="checkbox"/> SCHOOL/NONPROFIT SR ML PRGM	165.00	1625	<input type="checkbox"/> OPTION B		
<input type="checkbox"/> BAKERY	340.00	1651	TEMP FOOD FAC (FD PREP)	51.00 ea.	1665
<input type="checkbox"/> BAKERY - NO PREPARATION*	194.00	1652	TEMP FOOD FAC (PKG FOOD)	31.00 ea.	1664
<input type="checkbox"/> PRODUCE STAND	146.00	1607	PLUS BASE FEE	409.00	
<input type="checkbox"/> SATELLITE FOOD DISTRIB. FAC.	170.00	1693	<input type="checkbox"/> OPTION C		
<input type="checkbox"/> RESTRICTED FOOD SERVICE ESTAB.	219.00	1681	TEMP FOOD FAC (FD PREP)	31.00 ea.	1667
<input type="checkbox"/> CERTIFIED FARMERS' MARKET	277.00	1619	TEMP FOOD FAC (PKG FOOD)	18.00 ea.	1666
<input type="checkbox"/> RETAIL MARKET (OVER 15,000 sq.ft.)	417.00	1614	PLUS BASE FEE	409.00	
<input type="checkbox"/> RETAIL MARKET (6,000-14,999 sq.ft.)	328.00	1613	<input type="checkbox"/> MULTI-EVENT (OPTION A ONLY)		
<input type="checkbox"/> RETAIL MARKET (LESS 6,000 sq.ft.)	211.00	1612	TEMP FOOD FAC (FD PREP)	295.00 ea.	1663
<input type="checkbox"/> MOBILE FOOD FACILITY CAT. A	131.00 ea.	1631	TEMP FOOD FAC (PKG FOOD)	181.00 ea.	1662
<input type="checkbox"/> MOBILE FOOD FACILITY CAT. B	168.00 ea.	1632	<input type="checkbox"/> SWIM POOL	234.00	3611
<input type="checkbox"/> MOBILE FOOD FACILITY CAT. C	211.00 ea.	1633	<input type="checkbox"/> SPA POOL	121.00	3612
<input type="checkbox"/> MOBILE FOOD PREP UNIT	211.00 ea.	1635	<input type="checkbox"/> WADING POOL	121.00	3615
<input type="checkbox"/> SWAP MEET PKG. FD STAND	146.00 ea.	1648			
<input type="checkbox"/> COMMISSARY	248.00	1680			

I hereby certify that I am the person owning the above business, and I will comply with all State and local laws now in force or which may hereafter be enacted pertaining to such business.

SIGNED Richard Chry TITLE OR POSITION area manager

\*Bakery wherein no products are prepared or processed from the beginning state.  
Multiple Food or Swim/Spa Facility: 100% of highest prescribed fee, plus 70% of each remaining fee. Temp. Food Fac., Swap Meet Prepackaged Fd Stand, Satellite Distrib. Fac., Mobile Food Facility, Mobile Food Prep Unit are not included as multiples and shall pay the standard fees. Additions to a facility between annual billings will be prorated on a monthly basis.

OFFICIAL USE ONLY

NEW FACILITY     CHANGE OF OWNERSHIP (Previous owner's name) \_\_\_\_\_  
(Previous name of Facility/Business) \_\_\_\_\_

MISC CHANGE (Nature of change) \_\_\_\_\_

O/B ENTIRE ACCT.     DROP/ADD P/E \_\_\_\_\_    SOFT SERVE PLT # \_\_\_\_\_

RESTRICTIONS/COMMISSARY \_\_\_\_\_

COMMENTS \_\_\_\_\_

VEHICLE LIC. # & DECAL # \_\_\_\_\_

FACILITY ID# 601490    PROGRAM RECORD ID(S) # 001671

APPROVED UPON PAYMENT OF FEES    BY: Colleen Smith, REHS

DISAPPROVED    DATE: 10/31/97

2

ISSUED

OCT 31 1997

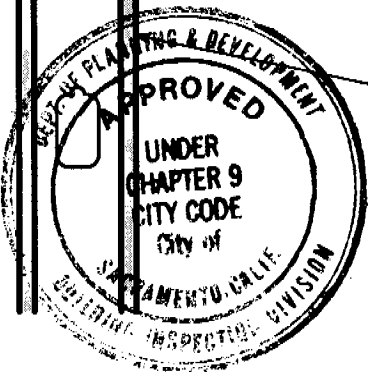
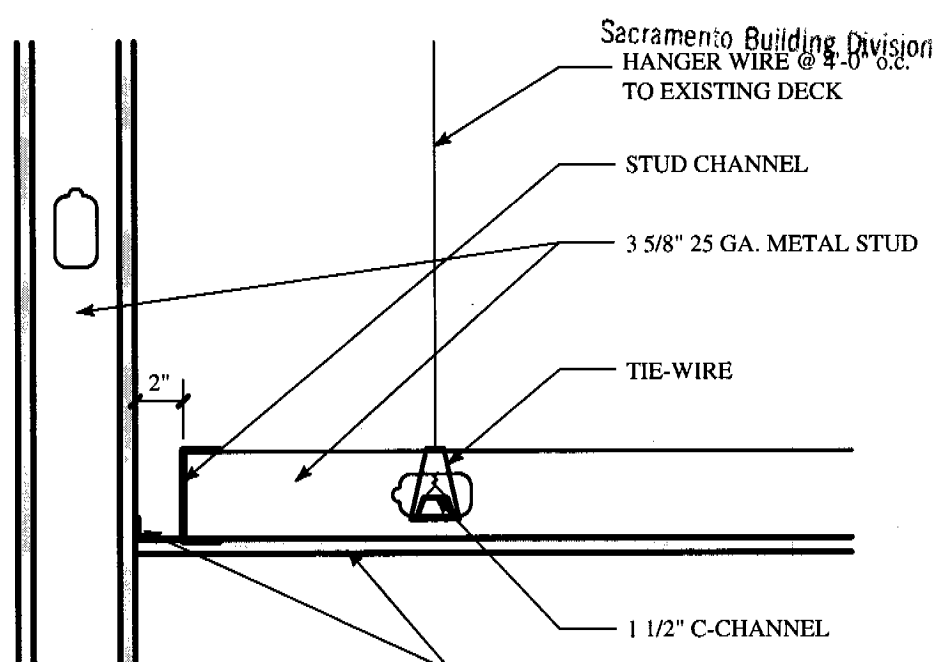

This set of plans and specifications must be kept on the job at all times and it is unlawful to make any changes or alterations from the same without written permission from the Building Inspection Division. The approval of this plan and specification SHALL NOT be held to permit or approve the violation of any City Ordinance or State Law.

Permit No. 97 12303 C

Address : 1689 Arden WY # 2022

**GYP. BOARD CEILING DETAIL** REV  $\Delta$  10/31/97  
SCALE: 1 1/2"=1'-0"



# CHINA INN, ARDEN FAIR

October 28, 1997

AkarStudio , PROJECT #: 97008  
1404 Third Street Promenade, Suite 201  
Santa Monica, CA 90401  
TEL: 310.393.0625  
FAX: 310.393.7692

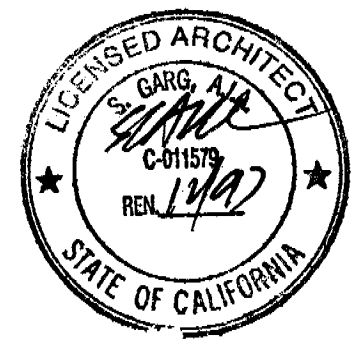

# CITY OF SACRAMENTO CERTIFICATE OF OCCUPANCY

For Information Contact (916) 264-5716

Building Address 1689 Arden Way #2022 Permit No. 9712303C

Building Use Fast road restaurant remodel Occupancy M

Building Owner Arden Fair Assoc / Heitman Construction Type II-NH

Owner Address 1689 Arden Way #1167, Sacramento, CA 95815 Sprinkled  Yes  No

Portion of Building Occupied #2022 DBA: China Inn Area \_\_\_\_\_ Sq. Ft.

10/31/1997 Ron Pecci  Bradford J. Boehm, P.E.  
Date Issued By: Print Sign City Building Official

This Certificate, issued pursuant to the requirements of Section 109 of the Uniform Building Code, certifies that at time of issuance the described portion of the building has been inspected for compliance with the Uniform Building Code as adopted per Title 9 of the Sacramento City Code for the group and division of occupancy and use for which the proposed occupancy is classified. Issuance of this certificate shall not be construed as an approval of a violation of any Codes, or Federal, State and City Laws or Ordinances. Certificates presuming to give authority to such violation shall not be valid. This certificate shall be posted in a conspicuous place on the premises and shall not be removed except by the City Building Official. No changes shall be made in the character of occupancy or use without approval of the City Building Official.

**POST IN A CONSPICUOUS PLACE**