

CONSTRUCTION LENDING AGENCY

I hereby affirm under penalty of perjury that there is a construction lending agency for the performance of the work for which this permit is issued (Sec. 3097, Civ.C.).

Lenders Name N/A
 Lenders Address _____

LICENSED CONTRACTORS DECLARATION

I hereby affirm under penalty of perjury that I am licensed under provisions of Chapter 9 (commencing with Section 7000) of Division 3 of the Business and Professions Code and my license is in full force and effect.

License Class B Lic. Number 731185
 Date 8/20/04 Contractor [Signature]
 Date 8/20/04 Contractor [Signature]

OWNER - BUILDER DECLARATION

I hereby affirm under penalty of perjury that I am exempt from the Contractors License Law for the following reason (Sec. 7031.5, Business and Professions Code: Any city or county which requires a permit to construct, alter, improve, demolish, or repair any structure, prior to its issuance, also requires the applicant for such permit to file a signed statement that he or she is licensed pursuant to the provisions of the Contractors License Law (Chapter 9 (commencing with Section 7000) of Division 8 of the Business and Professions Code) or that he or she is exempt therefrom and the basis for the alleged exemption. Any violation of Section 7031.5 by any applicant for a permit subjects the applicant to a civil penalty of not more than five hundred dollars (\$500.00):

I, as owner of the property, or my employees with wages as their sole compensation, will do the work, and the structure is not intended or offered for sale (Sec. 7044, Business and Professions Code: The Contractors License Law does not apply to an owner of property who builds or improves thereon, and who does such work himself or herself or through his or her own employees, provided that such improvements are not intended or offered for sale. If, however, the building or improvement is sold within one year of completion, the owner-builder will have the burden of proving that he or she did not build or improve for the purpose of sale.)

I, as owner of the property, am exclusively contracting with licensed contractors to construct the project (Sec. 7044, Business and Professions Code: The Contractors License Law does not apply to an owner of property who builds or improves thereon, and who contracts for such projects with a contractor(s) licensed pursuant to the Contractors License Law).

I am exempt under Sec. _____ B & P C for this reason _____
 Date _____ Owner _____ (Signature)

In issuing this building permit, the applicant represents, and the City relies on the representation of the applicant, that the applicant verified all measurements and locations shown on the application or accompanying drawings, and that the improvement to be constructed does not violate any law or private agreement relating to permissible or prohibited locations for such improvements. This building permit does not authorize any illegal location of any improvement or the violation of any private agreement relating to location of improvements.

I certify that I have read this application and state that all information is correct. I agree to comply with all city and county ordinances and state laws relating to building construction and hereby authorize representative of this city to enter upon the abovementioned property for inspection purposes.
 Date 8/20/04 Signature [Signature] Applicant or Agent

SITE ADDRESS 411 N. 16th St. SUITE _____ INSP. AREA 1
 ASSESSOR PARCEL NO. 081-0144-032 PERMIT NO. 0418969

NAME OF APPLICANT _____ ADDRESS _____ ZIP CODE _____ PHONE NO. _____
 LICENSED CONTRACTOR CRS Specialty Construction Roseville, CA 203 B Kenroy Lane 95678 916-786-3330
 BUSINESS OWNER Capital Casino

SIGN INFORMATION
 ATTACHED INTERIOR / ELECT. SINGLE FACED
 ILLUMINATED NON-ILLUMINATED BILLBOARD / SUBDIVISION
 INDIVIDUAL LETTERS PAINTED ON BUILDING LOGO
 METAL POLE DOUBLE FACED
 PLASTIC MONUMENT VINYL / CANVAS
 WOODEN PROJECTING RE-FACE
 SIGN COPY " CASINO "

5040199
 CITY OF SACRAMENTO PERMIT SERVICES
 BUILDING INSPECTION DIVISION 264-7619
 WORKER'S COMPENSATION DECLARATION

I hereby affirm under penalty of perjury that I have **PAID** the following declarations:
 I have and CITY OF SACRAMENTO consent to self-insure for workers' compensation as provided for by Section 3700 of the Labor Code, for the performance of work to be done by the permittee issued.
 I have and will maintain workers' compensation insurance, as required by Section 3700 of the Labor Code, for the performance of the work for which this permit is issued. My workers' compensation insurance carrier and policy number are: _____

Carrier State Comp
 Policy Number 2284-2003
 (This section need not be completed if the permit is for one hundred dollars (\$100) or less) I certify that in the performance of the work for which this permit is issued, I shall not employ any person in any manner so as to become subject to the workers' compensation laws of California and agree that if I should become subject to the workers' compensation provisions of Section 3700 of the Labor Code, I shall forthwith comply with those provisions.
 Date: 8/20/04 Applicant [Signature] (Signature)

WARNING: FAILURE TO SECURE WORKERS' COMPENSATION COVERAGE IS UNLAWFUL AND SHALL SUBJECT AN EMPLOYER TO CRIMINAL PENALTIES AND CIVIL FINES UP TO ONE HUNDRED THOUSAND DOLLARS (\$100,000) IN ADDITION TO THE COST OF COMPENSATION, DAMAGES AS PROVIDED FOR IN SECTION 3706 OF THE LABOR CODE, INTEREST AND ATTORNEY'S FEES.
 THIS PERMIT SHALL EXPIRE BY LIMITATION IF WORK AUTHORIZED IS NOT COMMENCED WITHIN 180 DAYS.

TYPE OF SIGN	SIGN VALUATION	APPROVED BY	DATE
A. _____	_____	<u>[Signature]</u>	<u>8/20/04</u>
B. \$ _____ PER SQ. FT. X _____ SQ. FT. = \$ _____			
APPROVED BY	DATE		
<u>[Signature]</u>	<u>8/20/04</u>		
DENIED BY	DATE		
BUILDING INSPECTOR	DATE		
<u>JRR</u>	<u>42905</u>		
ELECTRICAL INSPECTOR	DATE		
SIGN INSPECTOR	DATE		
FEES:	DATE	RECEIVED	AMOUNT
SIGN APPLICATION FEE			
SIGN PERMIT FEE			
ELECTRICAL SIGN FEE			
CITY BUSINESS LICENSE			
OTHER			
TOTAL FEES	\$		

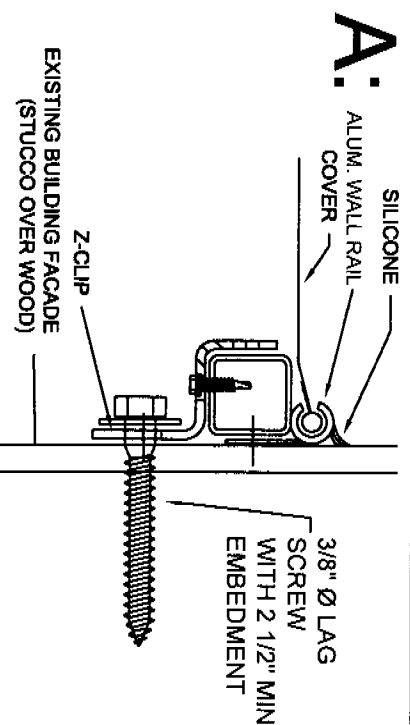
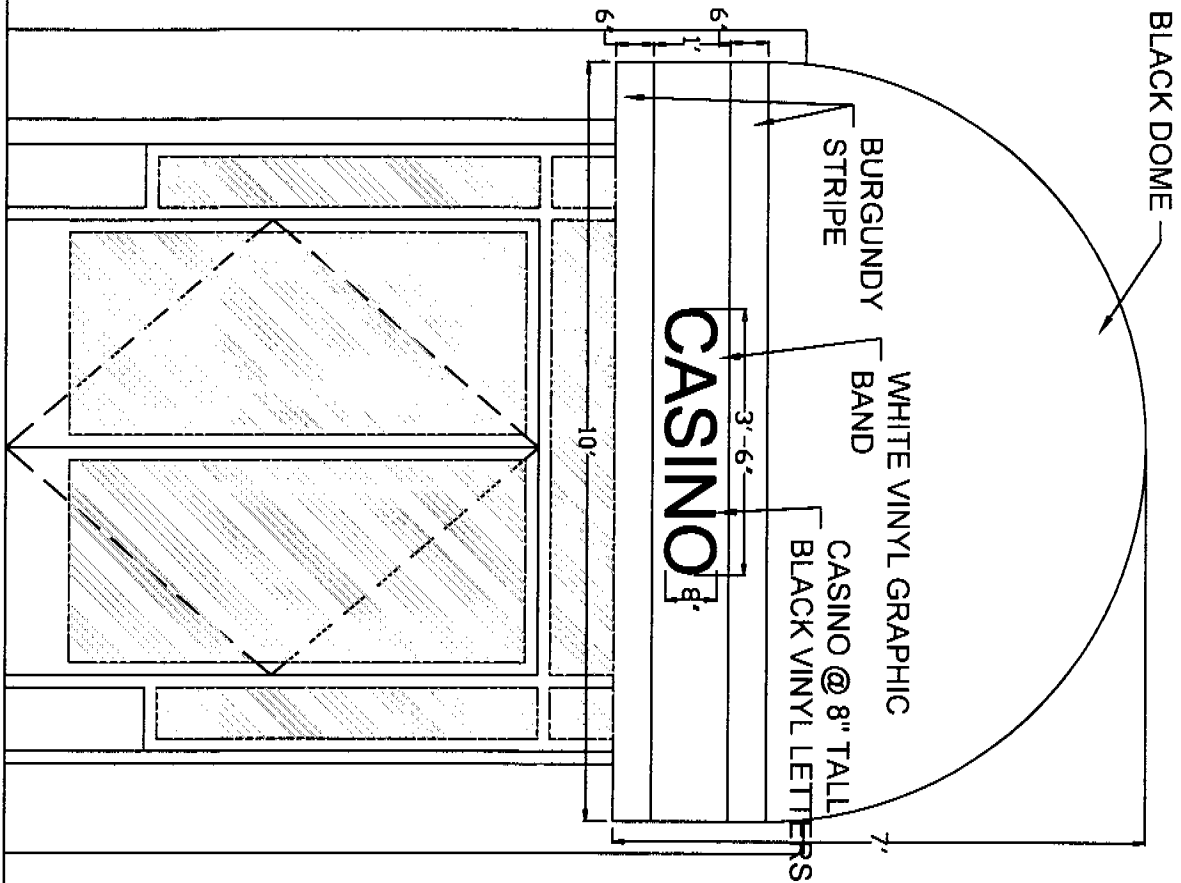

A: SPECIFICATION SCHEDULE

- 1) FRAMEWORK:
 - A) FRAMEWORK TO BE 046 X 1 1/2" ROUND & SQUARE TUBULAR STEEL THROUGHOUT UNLESS NOTED OTHERWISE
 - B) FRAMEWORK TO BE ALL WELDED CONSTRUCTION WITH CONTINUOUS 1/8" - 3/16" FILLET WELDS THROUGHOUT. ALL WELDS TO BE GROUND AND OR SANDED SMOOTH WHERE CONTACT WITH FABRIC COVER OCCURS.
 - C) ALL STEEL FRAMEWORK TO BE POWDER COATED
 - 1) COLOR: BLACK
- 2) FABRIC:
 - A) MANUFACTURE: SUNBRELLA FIRE-SIST.
 - B) COLOR: BURGUNDY #8931, BLACK #8908
 - C) STATE OF CALIFORNIA STATE FIRE MARSHAL REGISTERED VALVES FOR FLAME SPREAD AND SMOKE DENSITY IS CLASS A OR CLASS 1-BUILDING MATERIAL
 - D) THREAD: 138 & 92 PREMOFAST POLYESTER TO CLOSELY MATCH FABRIC.
- 3) FASTENERS:
 - A) FRAMEWORK TO BUILDING: USE 3/8 X 3" LAG SCREW WITH 3/8" WASHER THROUGH Z-CLIP INTO EXISTING WOOD CONSTRUCTION.
 - B) COVER TO FRAMEWORK:
 - 1) TOP: SEW 1/4 POLYESTER ROPE INTO 1" FLAT ROPE HEM ALONG TOP OF COVER, SLIDE INTO ALUMINUM WALL EXTRUSION.
 - 2) FRONT & ENDS: SEW 1" WIRE POCKET HEM ALONG BACK OF COVER, WRAP AROUND TO INSIDE OF FRAMEWORK AND FASTEN WITH 1/8" X 1 1/2" TEK SCREWS@O.C. TO ACHIEVE TAUT FIT.
 - 3) ENDS @ BACK: SEW 1" TEK TABS ALONG BACK OF COVER, WRAP AROUND TO INSIDE OF FRAMEWORK AND FASTEN WITH 1/8" X 1 1/2" TEK SCREWS @O.C. TO ACHIEVE TAUT FIT.
- 4) USE CLEAR CONSTRUCTION GRADE SILICONE CAULK ALONG JOINT BETWEEN AWNING AND EXTERIOR SURFACE BUILDING FACADE, AND AT ALL BUILDING PENETRATIONS TO ENSURE WEATHER TIGHT SEAL.

REVISIONS	DATE	BY

Capital Casino
 411 N. 16th Street
 Sacramento, CA

GPS SPECIALTY CONSTRUCTION INC.
 203 B KENROY LANE ROSEVILLE, CA 95678
 TELEPHONE: 916-786-3330 FAX: 916-786-0604
 CONTRACTOR LICENSE# 731186 B & D - 03

GPS SPECIALTY CONSTRUCTION INC. does not represent that these plans or the specifications in connection therewith are suitable, whether or not modified for any other site than the one they were prepared. GPS SPECIALTY CONSTRUCTION INC. disclaims responsibility for these plans and specifications if they were used in whole or in part at any other site. All drawings and written material appearing herein constitute the original and unpublished work of GPS SPECIALTY CONSTRUCTION INC. and the same may not be duplicated, used, or dictated without written consent of GPS SPECIALTY CONSTRUCTION INC.

DATE: 06/08/04
 SCALE: NOTED
 JOB: NOTED
 DRAWN: M.K.
 SHEET: 3
 OF 3 SHEETS



JOB COPY

CITY OF SACRAMENTO CALIFORNIA

PLANNING AND
BUILDING DEPARTMENT

1231 I STREET, ROOM 200
SACRAMENTO, CA 95814-2998

PHONE 916-264-5381

FAX 916-264-5543

STAFF LEVEL PROJECT REVIEW

DR Number: DR04-235
Address: 411 N. 16TH St.
Description: New Awnings
Staff Contact: Ryan Sandwick, 808-8497

Applicant/Owner: Doug Hawkins
Date Filed: 08-08-04
Date Approved: 08-23-04
APN: 001-0144-032

STAFF ACTION AND CONDITIONS OF APPROVAL:

Staff has reviewed the proposed project, and approves it with the following conditions of approval:

1. New storefront system to match existing framing and glass as drawn on approved plans.
2. Awning approved as drawn w/ signage requiring a separate permit.
3. Awning to match color and material per submitted sample.
4. All other notes and drawings on the final plans as submitted by the applicant are deemed conditions of approval. Any changes to the final set of plans stamped by Design Review staff shall be subject to review and approval prior to any changes.
5. The scope of work is limited to the above listed items. Any changes are subject to Design Review staff approval.

Ryan Sandwick
Design Review

ALL SIGN INSTALLATIONS ARE SUBJECT TO FIELD INSPECTION



ISSUED

SEP 03 2004

Sacramento Building Division