

CITY OF SACRAMENTO

Permit No: 9808518

1231 I Street, Sacramento, CA 95814

Insp Area: 1

Site Address: 730 K ST SAC

Sub-Type: NOTHR

Parcel No: 0060096010

Housing (Y/N): N

CONTRACTOR

PATS CANVAS COMPANY
4102 WAYSIDE LN
CARMICHAEL CA 95608

OWNER

ROY VAN VIET TRUSTS A/B
175 PEPPER AV
BURLINGAME CA 94010

ARCHITECT

Nature of Work: REPLACING EXISTING ALUMINUM AWNING WITH NEW CANVAS AWNING.

CONSTRUCTION LENDING AGENCY: I hereby affirm under penalty of perjury that there is a construction lending agency for the performance of the work for which this permit is issued (Sec. 3097, Civ. C).

Lender's Name Lender's Address

LICENSED CONTRACTORS DECLARATION: I hereby affirm under penalty of perjury that I am licensed under provisions of Chapter 9 (commencing with section 7000) of Division 3 of the Business and Professions Code and my license is in full force and effect.

License Class C61 License Number 446-454 Date 8-31-98 Contractor Signature [Signature]

OWNER-BUILDER DECLARATION: I hereby affirm under penalty of perjury that I am exempt from the contractors License Law for the following reason (Sec. 7031.5, Business and Professions Code; any city or county which requires a permit to construct, alter, improve, demolish, or repair any structure, prior to its issuance, also requires the applicant for such permit to file a signed statement that he or she is licensed pursuant to the provisions of the Contractors License Law (Chapter 9 (commencing with Section 7000) of Division 8 of the Business and Professions Code) or that he or she is exempt therefrom and the basis for the alleged exemption. Any violation of Section 7031.5 by any applicant for a permit subjects the applicant to a civil penalty of not more than five hundred dollars (\$500.00);

I, as a owner of the property, or my employees with wages as their sole compensation, will do the work, and the structure is not intended or offered for sale (Sec. 7044, Business and Professional Code: The Contractors License Law does not apply to an owner of property who builds or improves thereon, and who does such work himself or herself or through his/her own employees, provided that such improvements are not intended or offered for sale. If, however, the building or improvement is sold within one year of completion, the owner-builder will have the burden of proving that he/she did not build or improve for the purpose of sale.)

I, as owner of the property, am exclusively contracting with licensed contractors to construct the project (Sec. 7044, Business and Professions Code: The Contractors License Law does not apply to an owner of property who builds or improves thereon, and who contracts for such projects with a contractor(s) licensed pursuant to the Contractors License Law).

I am exempt under Sec. B & PC for this reason:

Date Owner Signature

IN ISSUING THIS BUILDING PERMIT, the applicant represents, and the city relies on the representation of the applicant, that the applicant verified all measurements and locations shown on the application or accompanying drawings and that the improvement to be constructed does not violate any law or private agreement relating to permissible or prohibited locations for such improvements. This building permit does not authorize any illegal location of any improvement or the violation of any private agreement relating to location of improvements.

I certify that I have read this application and state that all information is correct. I agree to comply with all city and county ordinances and state laws relating to building construction and hereby authorize representative(s) of this city to enter upon the abovementioned property for inspection purposes.

Date 8-31-98 Applicant/Agent Signature [Signature]

WORKER'S COMPENSATION DECLARATION: I hereby affirm under penalty of perjury one of the following declarations: I have and will maintain a certificate of consent to self-insure for workers' compensation as provided for by Section 3700 of the Labor Code, for the performance of work for which the permit is issued.

I have and will maintain workers' compensation insurance, as required by Section 3700 of the Labor Code, for the performance of the work for which this permit is issued. My workers' compensation insurance carrier and policy number are:

Carrier CLARNDON NATIONAL ERS. Policy Number OIKK 0000 821

(This section need not be completed if the permit is for \$100 or less) I certify that in the performance of the work for which this permit is issued, I shall not employ any person in any manner so as to become subject to the workers' compensation laws of California and agree that if I should become subject to the workers' compensation provisions of Section 3700 of the Labor Code, I shall forthwith comply with those provisions.

Date 8-31-98 Applicant Signature [Signature]

WARNING: FAILURE TO SECURE WORKER'S COMPENSATION COVERAGE IS UNLAWFUL AND SHALL SUBJECT AN EMPLOYER TO CRIMINAL PENALTIES AND CIVIL FINES UP TO ONE HUNDRED THOUSAND DOLLARS (\$100,000) IN ADDITION TO THE COST OF COMPENSATION, DAMAGES AS PROVIDED FOR IN SECTION 3706 OF THE LABOR CODE, INTEREST AND ATTORNEY'S FEE.

THIS PERMIT SHALL EXPIRE BY LIMITATION IF WORK IS NOT COMMENCED WITHIN 180 DAYS.

MEMORANDUM

Sacramento Fire Department

To: BUILDING DEPARTMENT

Date: 10-5-98

From: Gordon Duncan,
Fire Marshal

Subject: FIRE SYSTEM INSPECTION

A final inspection of the newly installed fire system at:

730 K ST

has been conducted by Inspector R. LAFOREST

on 10-2-98.

98-08518-C
Permit Number

150 SQ FT
Square Footage

New Annular
Type Inspection

The system is acceptable by this department.



By: Ross L. Woodman,
Fire Prevention Officer II

TI-134
F. D. Reference Number

Finalized
BI 10-5-98
No P/m, Elect

SITE PLAN

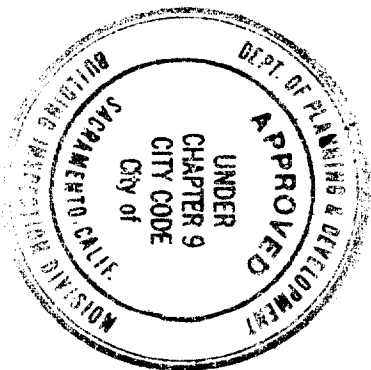

This set of plans and specifications must be kept on the job at all times and it is unlawful to make any changes or alterations from the same without written permission from the Building Inspection Division.

The approval of this plan and specifications SHALL NOT be held to permit or approve the violation of any City Ordinance or State Law.

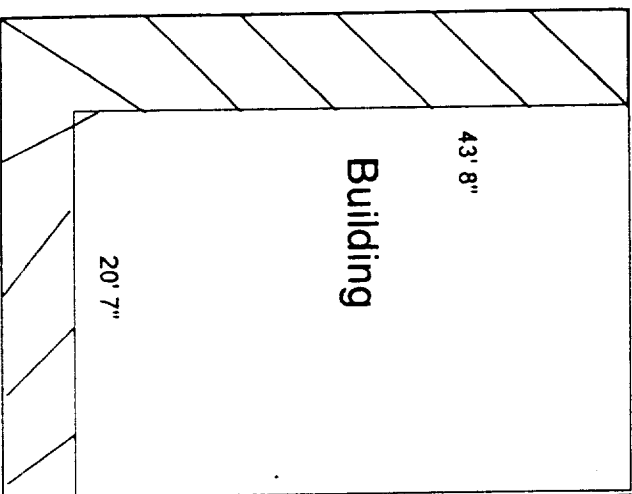

APPROVED
P. Zell 8/31/98
 SACRAMENTO
 FIRE DEPARTMENT

SEE ATTACHED Awnings
 INFORMATION FROM
 SUBBERS

Pats Canvas Company
 4102 Wayside Lane
 Carmichael, CA 95608
 916 485-6565
 Cont. License #466-454

ISSUED

AUG 31 1998

CITY OF SACRAMENTO
 DEVELOPMENT SERVICES DIV
 K Mini-Mart
 730 K Street
 Sacramento, CA

John Tang
 08298-114
 8-31-98

K Street

006-0096.010

View from K Street

20' 7"

K Mini-Mart Market & Deli

8' 11"

15' 4"

21'

8'

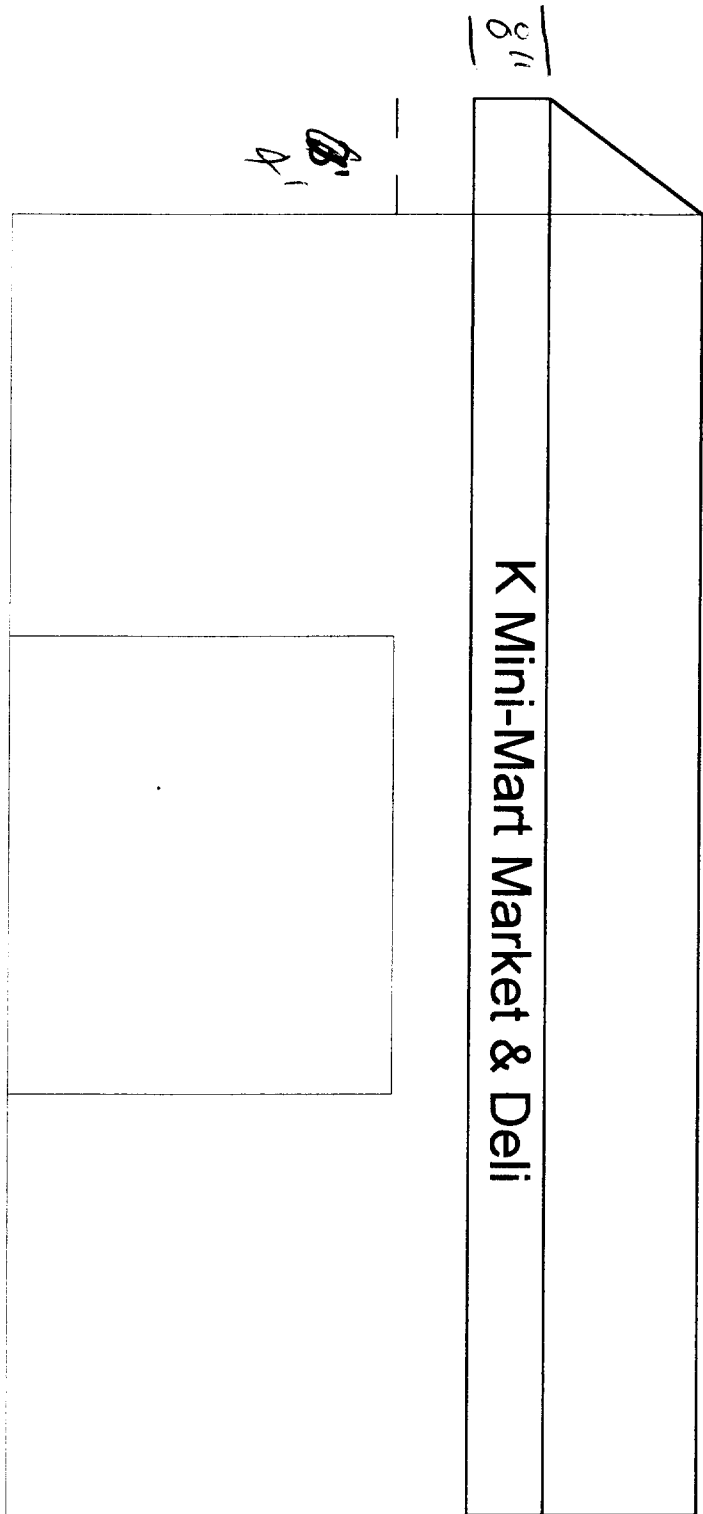

View from 8th Street

43' 8"

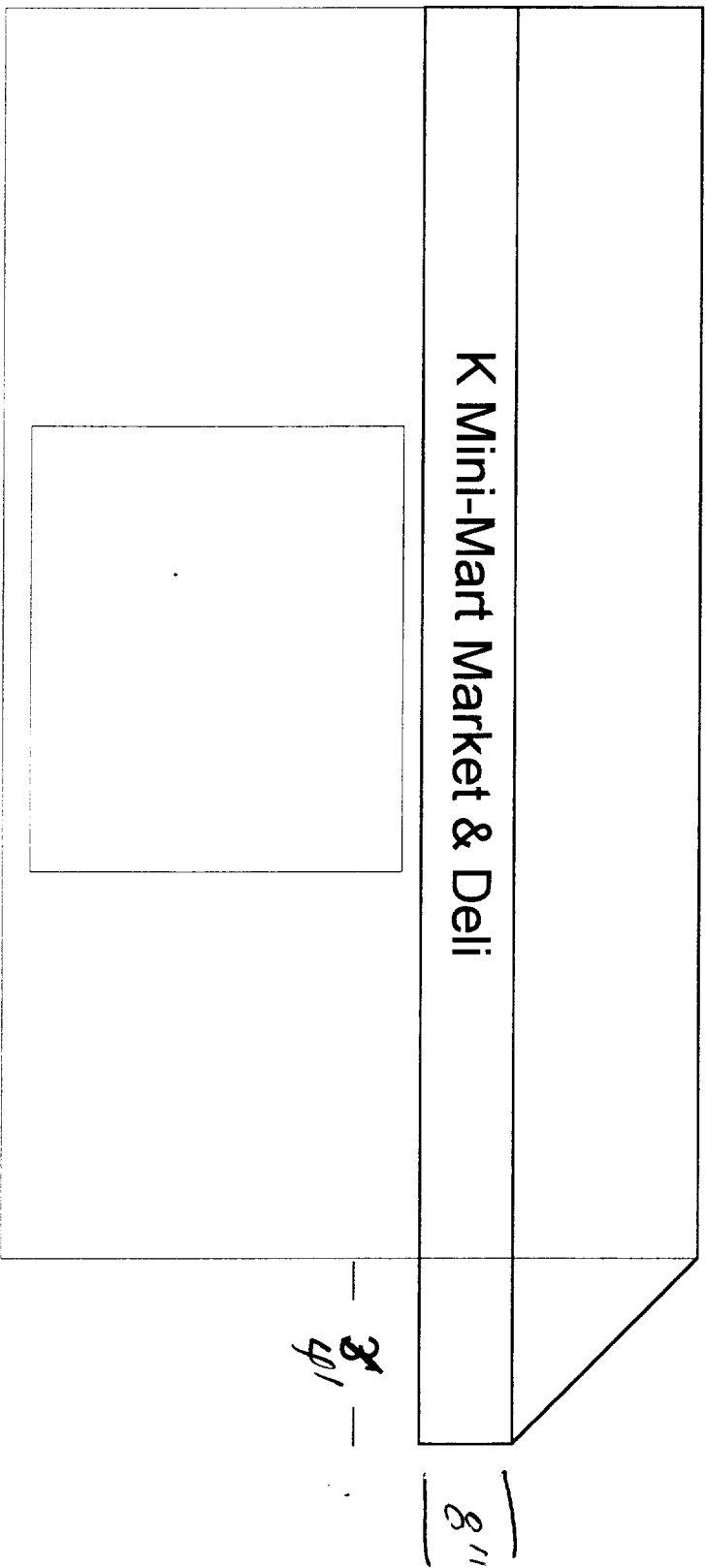

Z Bracket will be attached to the wall using #14 x 2" Lag bolts.
Z Brackets will be placed at back typically 4' on center.
Z Bracket is 1 1/2" wide, 2 1/4" high and 1/16" thick.
Pipe is 1" steel conduit.

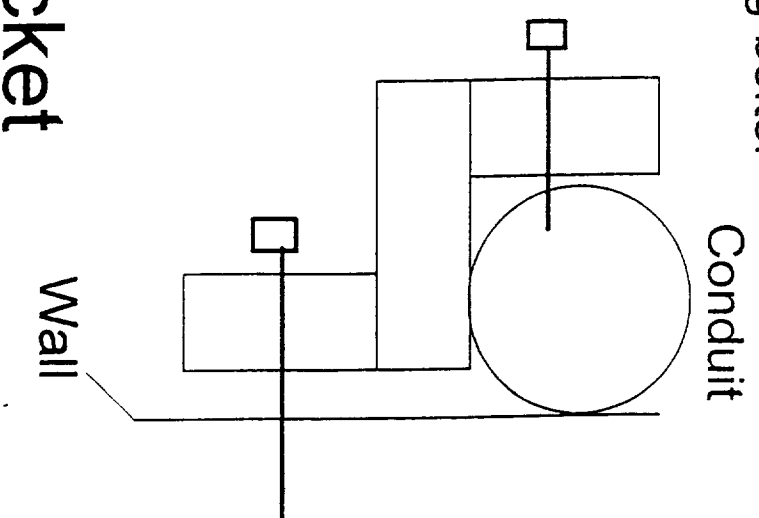

CONNECTION DETAIL

Z Bracket

Pat's Canvas Company
4102 Wayside Lane
Carmichael, CA 95608
916 485-6565
Cont. License #466-454

K Mini Mart
703 K Street
Sacramento, CA

TYPICAL CONNNECTION DETAIL

3' ON CENTER TYPICAL SPACING BETWEEN BOWS

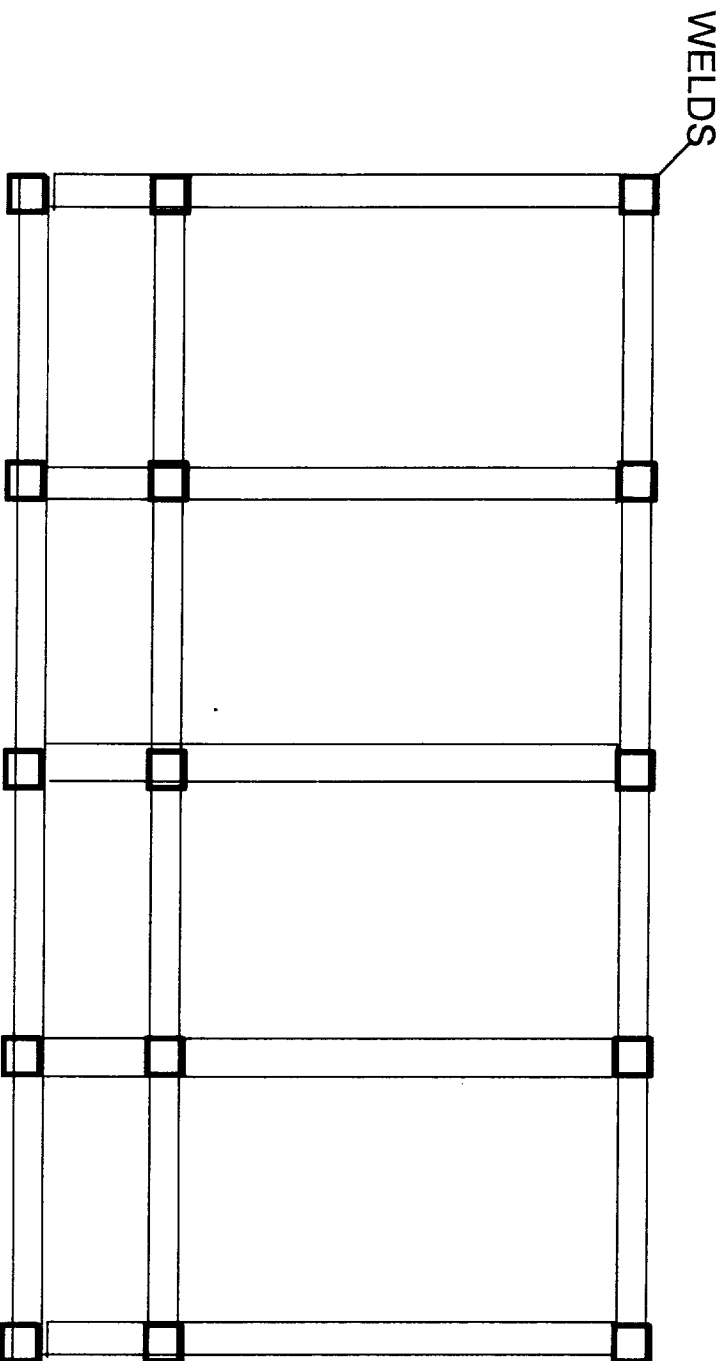



Generic Classification	Solution Dyed Modacrylic	Flame Resistance (FR)	Fabric does not melt drip and is inherently flame retardant passing the following FR requirements: <ul style="list-style-type: none"> •California State Fire Marshall's Test Procedure #801, Title 19, Registration #F368.01 •NFPA 701. •ASTM E-84-84 – Values for flame spread and smoke density is Class A or Class 1 building material. •F.A.A. 25.853(b) interior aircraft textiles and furnishings. •FMVSS302: Auto, bus, train. •CPAI-84: Tent walls and roof. •New York Board of Standards 294-40-SR. •UFAC: Upholstered furniture. •NFPA 1975 – Fireman's station uniform (FTMS 5903-191) and institutional blankets. •UL 214 Certification (U.S.) •CAN/UL 5109 Certification (Canada). •Outside North America –Consult Glen Raven for Specifications.
Description	Woven fabric made of 100% SEF/FR® Self-extinguishing fibers. These are modacrylic solution dyed fibers with a fluorocarbon finish.		
Weight	Approximately 9.25 oz. per square yard. 314 grams per square meter.		
Width	60 inches or 152.4 cm.		
Color	Very resistant to ultraviolet rays and color degradation (see warranty). Most colors tested up to 1500 hours in fadeometer with minimal or no change. Fade resistant to most chemicals.		
Durability/ Average Life Span	5-10 years. (Depends on climate and proper use of fabric.)		
Underside	Same as top surface, both sides alike.		
Surface	Plain Weave. Excellent breathability.	Mildew Resistant	Excellent. Fabric will not support growth of mildew. Mildew growing on foreign matter attached to fabric is easily removed.
Transparency Level	Light shades translucent for good illuminated use.	Chemical Resistance	Fabric highly resistant to acids, alkalis, and solvents.
Abrasion Resistance	Good.	Water Repellency	Excellent.
Flexibility	Excellent in both hot and very cold conditions. Will not crack or peel.	Oil Resistance	Good.
Fabric Identification	Contrasting marker yarn in selvage gives positive identification.	Sewability	Excellent.
		Heat Sealing	Can be heat sealed using sealing tape and heat source such as radio frequency bar type welder.

FIVE YEAR LIMITED WARRANTY FOR SUNBRELLA FIRESIST®

This warranty is valid only if its accompanying certificate is completed and mailed within 10 days of installation.

What is Covered?

This warranty covers the fabric becoming unserviceable because of loss of color or strength from normal exposure conditions including sunlight, mildew, rot and atmospheric chemicals. It does not cover labor and installations supplied by the dealer.

How Long is the Coverage Period?

The warranty coverage runs for 5 years from the date of original installation.

What Will Glen Raven Do?

Glen Raven will supply new fabric free to replace the fabric which becomes unserviceable.

How Can You Get Service?

Call the dealer from whom you purchased the product to inspect the installation. The dealer will contact Glen Raven and secure replacement fabric for you.

How Does State Law Apply?

This warranty gives you specific legal rights and you may also have other rights which vary from state to state.



FR97-545



Glen Raven Mills, Inc.
1831 N. Park Avenue
Glen Raven, NC 27217
910-227-6211
Fax: 910-229-4039





NEW FANCY STRIPE

Style #8705-Hemlock Tweed Fancy Stripe



NEW STYLES – 6 BAR STRIPES

Style #8710-Teal Blue/Natural; Style #8703-Crimson Red/Natural; Style #8701- Arctic Blue/Natural; Style #8702-Sunburst Yellow/Natural; and Style #8737-Forest Green/Natural.

SUNBRELLA FIRESIST®:

- Inherently flame retardant fabric.
- Woven from 100% modacrylic fiber.
- 60" wide, 9.25 ounces per square yard.
- Put up on 50-yard rolls; 200-yard cases.
- Meets most fire codes for exterior and interior fabric use.
- Fire retardancy is inherent – cannot be washed out.
- Will not drip melt.
- Very color fast to sunlight and strong chemicals.
- Strength and color guaranteed for five years.
- Excellent mildew resistance.
- Fabric breathes for cooler covered area.
- Handles easily in all weather. Will not crack or peel.



NEW FANCY STRIPE

Style #8717-Royal Blue Fancy Stripe