

CONSTRUCTION LENDING AGENCY

I hereby affirm under penalty of perjury that there is a construction lending agency for the performance of the work for which this permit is issued (Sec. 3097, Civ.C.).

Lenders Name _____
 Lenders Address _____

LICENSED CONTRACTORS DECLARATION

I hereby affirm under penalty of perjury that I am licensed under provisions of Chapter 9 (commencing with Section 7000) of Division 3 of the Business and Professions Code and my license is in full force and effect.

License Class C-10 Lic. Number 303019
 Contractor Carl Cook
 Date 7/2/02 (Signature)

OWNER - BUILDER DECLARATION

I hereby affirm under penalty of perjury that I am exempt from the Contractors License Law for the following reason (Sec. 7031.5, Business and Professions Code: Any city or county which requires a permit to construct, alter, improve, demolish, or repair any structure, prior to its issuance, also requires the applicant for such permit to file a signed statement that he or she is licensed pursuant to the provisions of the Contractors License Law (Chapter 9 (commencing with Section 7000) of Division 8 of the Business and Professions Code) or that he or she is exempt therefrom and the basis for the alleged exemption. Any violation of Section 7031.5 by any applicant for a permit subjects the applicant to a civil penalty of not more than five hundred dollars (\$500.00):

I, as owner of the property, or my employees with wages as their sole compensation, will do the work, and the structure is not intended or offered for sale (Sec. 7044, Business and Professions Code: The Contractors License Law does not apply to an owner of property who builds or improves thereon, and who does such work himself or herself or through his or her own employees, provided that such improvements are not intended or offered for sale. If, however, the building or improvement is sold within one year of completion, the owner-builder will have the burden of proving that he or she did not build or improve for the purpose of sale.)

I, as owner of the property, am exclusively contracting with licensed contractors to construct the project (Sec. 7044, Business and Professions Code: The Contractors License Law does not apply to an owner of property who builds or improves thereon, and who contracts for such projects with a contractor(s) licensed pursuant to the Contractors License Law).

I am exempt under Sec. _____ B & P C for this reason _____
 Date _____ Owner _____ (Signature)

In issuing this building permit, the applicant represents, and the City relies on the representation of the applicant, that the applicant verified all measurements and locations shown on the application or accompanying drawings and that the improvement to be constructed does not violate any law or private agreement relating to permissible or prohibited locations for such improvements. This building permit does not authorize any illegal location of any improvement or the violation of any private agreement relating to location of improvements.

I certify that I have read this application and state that all information is correct. I agree to comply with all city and county ordinances and state laws relating to building construction and hereby authorize representative of this city to enter upon the abovementioned property for inspection purposes.
 Date 7/2/02 Signature of Applicant or Agent Carl Cook

SITE ADDRESS

1300 El Camino Ave.

ASSESSOR PARCEL NO.

227-0972-005

ADDRESS

P.O. Box 15100 Sac. Ca.

PERMIT NO. 02209144

NAME OF APPLICANT

Superior Self Storage

ZIP CODE

95851

LICENSED CONTRACTOR

Pacific Neon

PHONE NO.

927 9270527

BUSINESS OWNER

Superior Self Storage

SIGN INFORMATION

- ATTACHED
- ILLUMINATED
- INDIVIDUAL LETTERS
- METAL
- PLASTIC
- WOODEN
- INTERIOR / ELECT.
- NON-ILLUMINATED
- PAINTED ON BUILDING
- POLE
- MONUMENT
- PROJECTING
- SINGLE FACED
- BILLBOARD / SUBDIVISION
- LOGO
- DOUBLE FACED
- VINYL/GATOR FOAM
- RE-FACE

SIGN COPY Superior Self Storage

S-22173

CITY OF SACRAMENTO BUILDING INSPECTION DIVISION
 PERMIT SERVICES 264-7619

WORKERS' COMPENSATION DECLARATION

I hereby affirm under penalty of perjury one of the following declarations:

I have and will maintain a certificate of consent to self-insure for workers' compensation as provided for by Section 3700 of the Labor Code, for the performance of work for which the permit is issued.

I have and will maintain workers' compensation insurance, as required by Section 3700 of the Labor Code, for the performance of the work for which this permit is issued. My workers' compensation insurance carrier and policy number are:
 Carrier State Fund
 Policy Number 478-87

(This section need not be completed if the permit is for one hundred dollars (\$100) or less) I certify that in the performance of the work for which this permit is issued, I shall not employ any person in any manner so as to become subject to the workers' compensation laws of California and agree that if I should become subject to the workers' compensation provisions of Section 3700 of the Labor Code, I shall forthwith comply with those provisions.
 Date: 7/2/02 Applicant: Carl Cook (Signature)

WARNING: FAILURE TO SECURE WORKERS' COMPENSATION COVERAGE IS UNLAWFUL AND SHALL SUBJECT AN EMPLOYER TO CRIMINAL PENALTIES AND CIVIL FINES UP TO ONE HUNDRED THOUSAND DOLLARS (\$100,000) IN ADDITION TO THE COST OF COMPENSATION. DAMAGES AS PROVIDED FOR IN SECTION 3706 OF THE LABOR CODE, INTEREST AND ATTORNEY'S FEES.

THIS PERMIT SHALL EXPIRE BY LIMITATION IF WORK AUTHORIZED IS NOT COMMENCED WITHIN 180 DAYS.

INSP. AREA

4

(A) HEIGHT 6' (B) LENGTH 8
 (A X B) SIGN AREA 48
 POLE SIZE _____ FOOTING SIZE _____
 STREET FRONTAGE (FT) _____
 OCCUPANCY FRONTAGE (FT) _____

ENGINEERING REQUIRED? YES NO APPROVED BY _____
 DESIGN REVIEW REQUIRED? YES NO APPROVED BY _____
 SPECIAL PERMIT REQUIRED? YES NO # _____
 VARIANCE REQUIRED? YES NO # _____
 LOCATED IN PUD? YES NO WHICH PUD? _____

SIGN VALUATION
 A. TYPE OF SIGN Monument
 B. \$ _____ PER SQ. FT. X _____ SQ. FT. = \$ _____
 APPROVED BY MS DATE 7/2/02
 DENIED BY _____ DATE _____

FINAL INSPECTIONS
 BUILDING INSPECTOR MS DATE 7/26/02
 ELECTRICAL INSPECTOR MS DATE 7/26/02

| FEES: | DATE | RECEIVED | AMOUNT |
|-----------------------|------|----------|--------|
| SIGN APPLICATION FEE | | | |
| SIGN PERMIT FEE | | | |
| ELECTRICAL SIGN FEE | | | |
| CITY BUSINESS LICENSE | | | |
| OTHER | | | |
| TOTAL \$ | | | |

CONSTRUCTION LENDING AGENCY

I hereby affirm under penalty of perjury that there is a construction lending agency for the performance of the work for which this permit is issued (Sec. 3097, Civ. C).

Lenders Name _____
Lenders Address _____

LICENSED CONTRACTORS DECLARATION

I hereby affirm under penalty of perjury that I am licensed under provisions of Chapter 9 (commencing with Section 7000) of Division 3 of the Business and Professions Code and my license is in full force and effect.

License Class C-10 Lic. Number 303019
Date 7/2/02 Contractor Carl Cook
(Signature)

OWNER - BUILDER DECLARATION

I hereby affirm under penalty of perjury that I am exempt from the Contractors License Law for the following reason (Sec. 7031.5, Business and Professions Code: Any city or county which requires a permit to construct, alter, improve, demolish, or repair any structure, prior to its issuance, also requires the applicant for such permit to file a signed statement that he or she is licensed pursuant to the provisions of the Contractors License Law (Chapter 9 (commencing with Section 7000) of Division 8 of the Business and Professions Code) or that he or she is exempt therefrom and the basis for the alleged exemption. Any violation of Section 7031.5 by any applicant for a permit subjects the applicant to a civil penalty of not more than five hundred dollars (\$500.00):

I, as owner of the property, or my employees with wages as their sole compensation, will do the work, and the structure is not intended or offered for sale (Sec. 7044, Business and Professions Code: The Contractors License Law does not apply to an owner of property who builds or improves thereon, and who does such work himself or herself or through his or her own employees, provided that such improvements are not intended or offered for sale. If, however, the building or improvement is sold within one year of completion, the owner-builder will have the burden of proving that he or she did not build or improve for the purpose of sale.)

I, as owner of the property, am exclusively contracting with licensed contractors to construct the project (Sec. 7044, Business and Professions Code: The Contractors License Law does not apply to an owner of property who builds or improves thereon, and who contracts for such projects with a contractor(s) licensed pursuant to the Contractors License Law).

I am exempt under Sec. _____ B & P C for this reason _____

Date _____ Owner _____ (Signature)
In issuing this building permit, the applicant represents, and the City relies on the representation of the applicant, that the applicant verified all measurements and locations shown on the application or accompanying drawings and that the improvement to be constructed does not violate any law or private agreement relating to permissible or prohibited locations for such improvements. This building permit does not authorize any illegal location of any improvement or the violation of any private agreement relating to location of improvements.

I certify that I have read this application and state that all information is correct. I agree to comply with all city and county ordinances and state laws relating to building construction and hereby authorize representative of the City to enter upon the abovementioned property for inspection purposes.

Date 7/2/02 Signature of Applicant or Agent Carl Cook

SITE ADDRESS 1800 El Camino Ave SUITE _____ INSP. AREA 4

ASSESSOR PARCEL NO. 277-0032-005 PERMIT NO. 0210103

LICENSED CONTRACTOR NAME OF APPLICANT Pacific Neon ADDRESS P.O. Box 15100 Sac. Ca. ZIP CODE 95851 PHONE NO. 927 0527

BUSINESS OWNER Superior Self Storage SIGN INFORMATION

ATTACHED INTERIOR / ELECT. SINGLE FACED
 ILLUMINATED NON-ILLUMINATED BILLBOARD / SUBDIVISION
 INDIVIDUAL LETTERS PAINTED ON BUILDING LOGO
 METAL POLE DOUBLE FACED
 PLASTIC MONUMENT VINYL/CATOR FOAM
 WOODEN PROJECTING RE-FACE

SIGN COPY Superior Self Storage
S-02174

CITY OF SACRAMENTO PERMIT SERVICES
BUILDING INSPECTION DIVISION 264-7619

WORKER'S COMPENSATION DECLARATION

I hereby affirm under penalty of perjury one of the following declarations:

I have and will maintain a certificate of consent to self-insure for workers' compensation as provided for by Section 3700 of the Labor Code, for the performance of work for which the permit is issued.

I have and will maintain workers' compensation insurance, as required by Section 3700 of the Labor Code, for the performance of the work for which this permit is issued. My workers' compensation insurance carrier and policy number are:

Carrier State Fund
Policy Number 478-87

(This section need not be completed if the permit is for one hundred dollars (\$100) or less) I certify that in the performance of the work for which this permit is issued, I shall not employ any person in any manner so as to become subject to the workers' compensation laws of California and agree that if I should become subject to the workers' compensation provisions of Section 3700 of the Labor Code, I shall forthwith comply with those provisions.

Date: 7/02/02 Applicant: Carl Cook
(Signature)

WARNING: FAILURE TO SECURE WORKERS' COMPENSATION COVERAGE IS UNLAWFUL AND SHALL SUBJECT AN EMPLOYER TO CRIMINAL PENALTIES AND CIVIL FINES UP TO ONE HUNDRED THOUSAND DOLLARS (\$100,000) IN ADDITION TO THE COST OF COMPENSATION. DAMAGES AS PROVIDED FOR IN SECTION 3706 OF THE LABOR CODE, INTEREST AND ATTORNEY'S FEES.

THIS PERMIT SHALL EXPIRE BY LIMITATION IF WORK AUTHORIZED IS NOT COMMENCED WITHIN 180 DAYS.

| | | | |
|-------------------------|--------------------|--------------------------|-------------------|
| (A) HEIGHT | <u>2</u> | (B) LENGTH | <u>17</u> |
| (A X B) SIGN AREA | <u>34</u> | FOOTING SIZE | |
| POLE SIZE | | STREET FRONTAGE (FT) | <u>87</u> |
| OCCUPANCY FRONTAGE (FT) | | OFFICE USE ONLY | |
| ENGINEERING REQUIRED? | YES NO | APPROVED BY | |
| DESIGN REVIEW REQUIRED? | YES NO | SPECIAL PERMIT REQUIRED? | YES NO |
| VARIANCE REQUIRED? | YES NO | LOCATED IN PUD? | YES NO WHICH PUD? |
| SIGN VALUATION | | | |
| A. TYPE OF SIGN | <u>cabined</u> | SQ. FT. = \$ | |
| B. \$ PER SQ. FT. X | | DATE | <u>7/26/02</u> |
| APPROVED BY | <u>MP</u> | DATE | <u>7/26/02</u> |
| DENIED BY | | DATE | |
| FINAL INSPECTIONS | | | |
| BUILDING INSPECTOR | <u>[Signature]</u> | DATE | <u>4-26-05</u> |
| ELECTRICAL INSPECTOR | <u>[Signature]</u> | DATE | <u>4-26-05</u> |
| SIGN INSPECTOR | | DATE | |
| FEES: | | RECEIVED | |
| SIGN APPLICATION FEE | | DATE | <u>7/3 25</u> |
| SIGN PERMIT FEE | | AMOUNT | |
| ELECTRICAL SIGN FEE | | | |
| CITY BUSINESS LICENSE | | | |
| OTHER | | | |
| TOTAL \$ | | | |

PROVIDE A MINIMUM OF
10' FEET SIGN SETBACK
FROM PROPERTY LINE



CITY OF SACRAMENTO
DESIGN REVIEW
PROJECT NO.: 25-156
APPROVED BY: *Luis Saldan*
APPROVAL DATE: 7/18/02

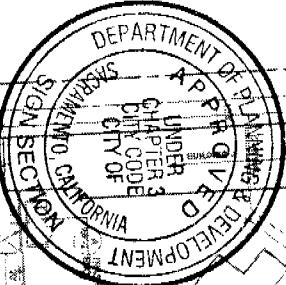
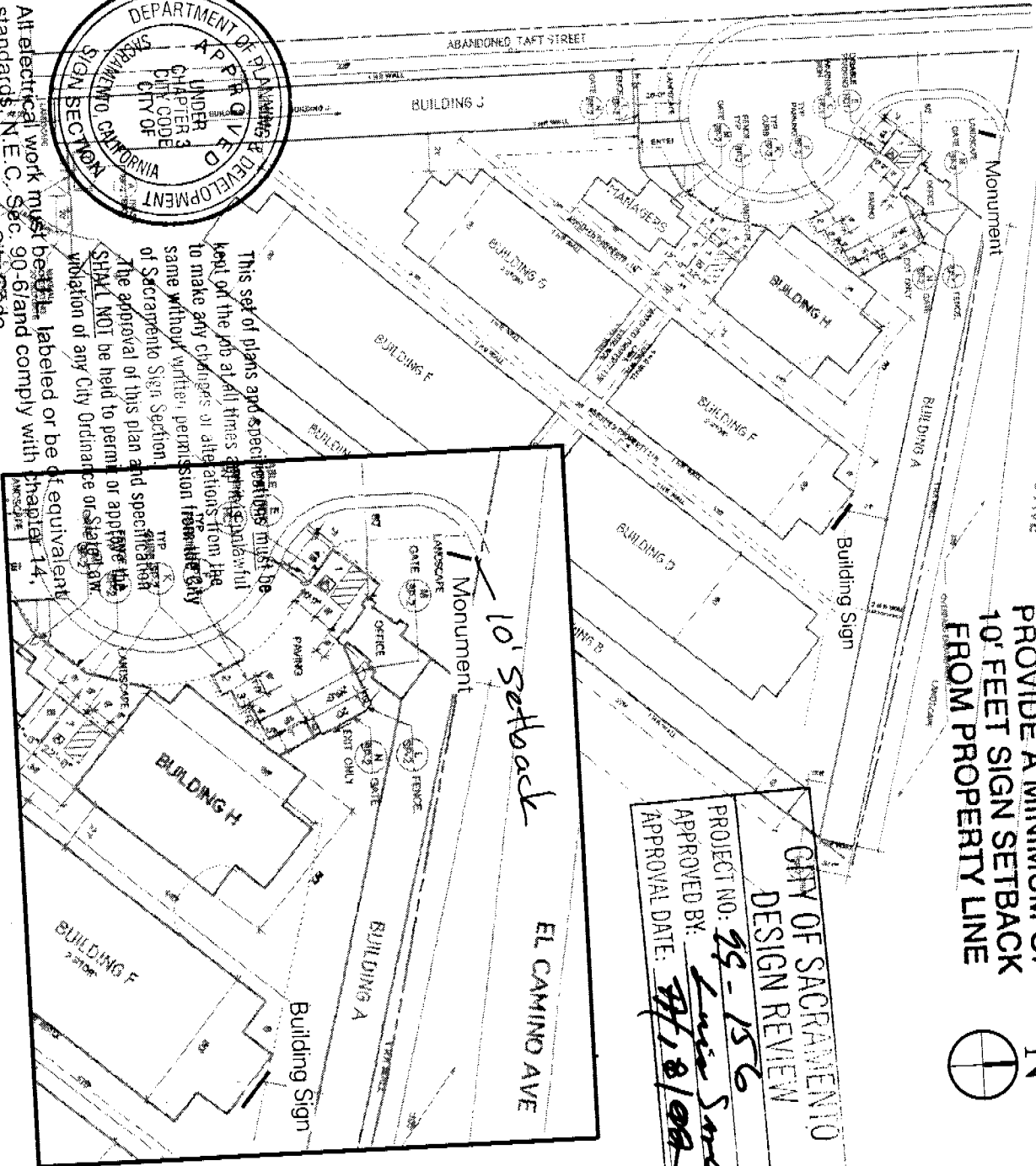

This set of plans and specifications must be kept on the job at all times and approved in full to make any changes or alterations from the same without written permission from the City of Sacramento Sign Section. The approval of this plan and specifications SHALL NOT be held to permit violation of any City Ordinance or State law.

All electrical work must be done in accordance with standards N.E.C. Sec. 90-6 and comply with Div. 2 of Sacramento City Code.

EQUIPMENT MUST BE USED AS DESIGN INTENDED
ALL SIGN INSTALLATIONS ARE SUBJECT TO FIELD INSPECTIONS



P.O. BOX 15100
SACRAMENTO CA, 95851
PH: 916.927.0527
FAX: 916.927.2414
WWW.PACIFICNEON.COM
COPYRIGHT ©2002

Client: Superior Self Storage
Address: 1300 El Camino Avenue Sacramento, CA
Account: Franz Deutsch
Project No: 02-7368
Date: 14 May 2002

Client Approval:

| Revision | Date |
|----------|------|
| A | |
| B | |
| C | |
| Final | |

Production Approval:
CITY COPY
Drawing
3

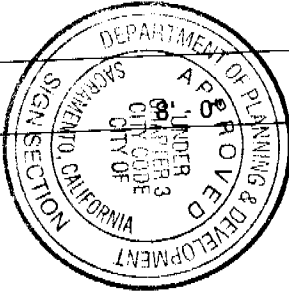

All electrical work must be U.L. labeled or be of equivalent standards, N.E.C. Sec. 90-6/and comply with chapter 14, Div. 2 of Sacramento City Code

EQUIPMENT MUST BE USED AS DESIGN INTENDED

ALL SIGN INSTALLATION PART SUBJECT TO FIELD INSPECTIONS

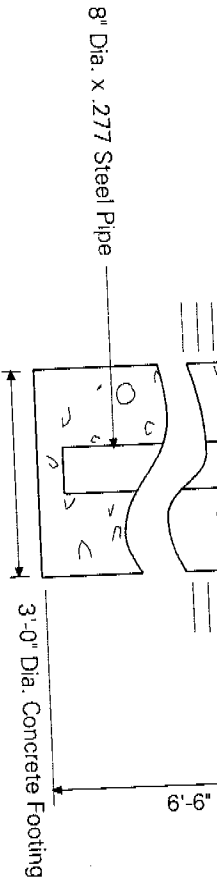
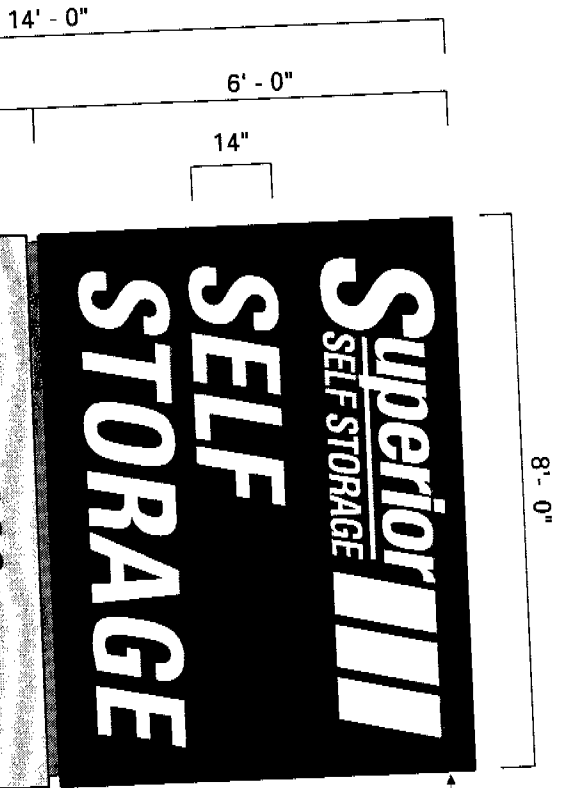

FOOTING INSPECTION REQUIRED

A D/F Illuminated Monument
Scale 3/8" = 1' - 0"

Specifications

- 1) Aluminum Extrusion Cabinet with Rout Faces Backed with White 015 SG Acrylic. Illuminate with Fluorescent Lamps.
- Background Painted Dark Green Matthews 22112, Satin Finish (Rb Roof Fern Green Ph. 909 875 8529)
- 2) Aluminum Base Paint to Match Final Building Specifications, Texcoat Finish.
- 3) FCO Letters Painted Dark Green Matthews 22112, Satin Finish.

CITY OF SACRAMENTO
DESIGN REPORT

PROJECT NO: DR 55-154
APPROVED BY: [Signature]
APPROVAL DATE: 2/18/02

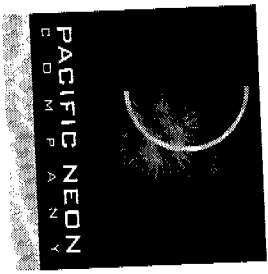

P.O. BOX 15100
SACRAMENTO CA, 95851
PH: 916.927.0527
FAX: 916.927.2414
WWW.PACIFICNEON.COM
COPYRIGHT ©2002

Client: Superior Self Storage
Address: 1300 El Camino Avenue Sacramento, CA
Account: Franz Deutsch
Project No: 02-7368
Date: 14 May 2002

| Client Approval: | Revision: | Date |
|------------------|-----------|----------|
| [Signature] | B | 6.10.02 |
| [Signature] | C | 6.26.002 |
| Final | | |

Production Approval:

1



APPROVED

Typical D/F Cabinet Display Installation

THE APPROVAL OF ALL ELECTRICAL WORK IS SUBJECT TO FIELD INSPECTIONS.

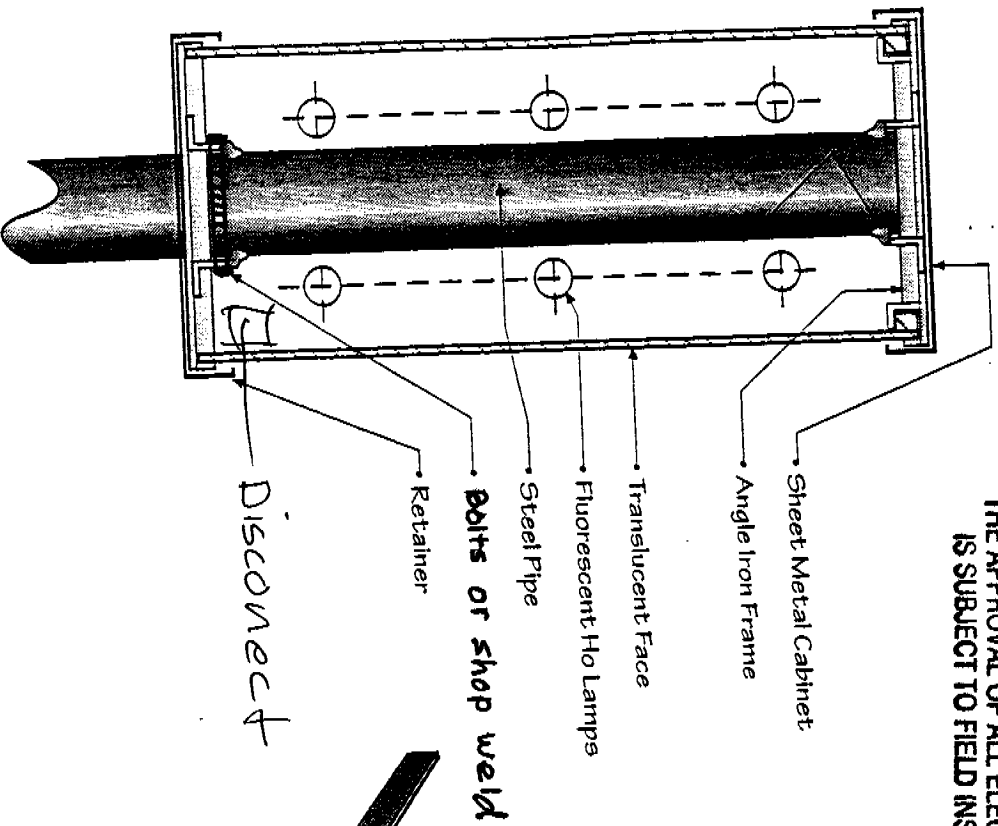

Cabinet To Pipe Attachment - Typical

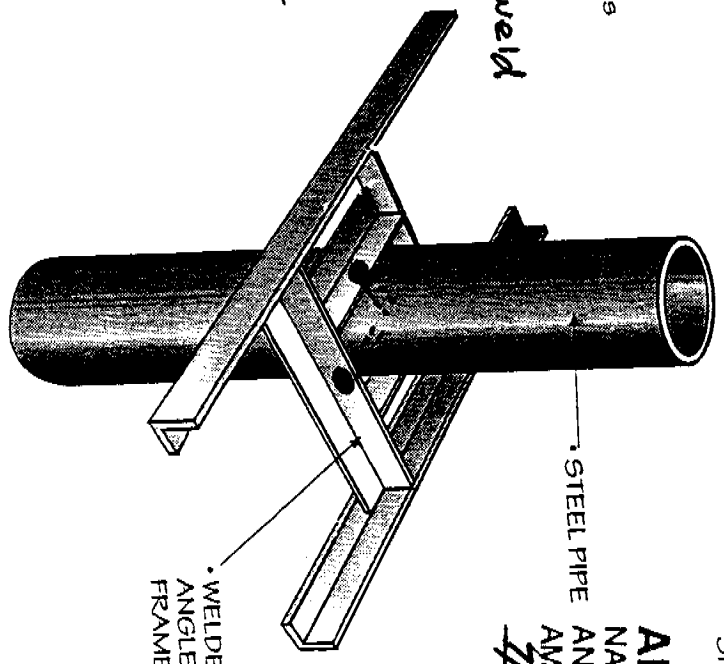

ILLUMINATED D/F CABINET INSTALLATION

SECTION DETAIL AT LEFT IS REPRESENTATIVE OF A TYPICAL ILLUMINATED CABINET DISPLAY INSTALLATION.

WALL MATERIAL AND/OR ELECTRICAL ACCESS MAY DIFFER FROM ILLUSTRATION.

PLEASE REFER TO ENCLOSED AND/OR ATTACHED DETAILS, ORIGINAL ARCHITECTURAL INFORMATION OR FIELD VERIFICATION FOR ACTUAL ON SITE WORKING CONDITIONS

APPROVED PER 1996
 NATIONAL ELECTRICAL CODE
 AND CITY OF SACRAMENTO
 AMENDMENTS
Thompson Kelly
 ELECTRICAL DIVISION

QTY: VARIOUS
DATE: 7 AUG 96

ACCOUNT: 96-0000

LOCATION: VARIOUS

FIG: 1 OF 1

1576 SIERRA AVE., SACRAMENTO, CA 95815 - 916.927.0627 FAX 916.927.2414 © 1996

Pacific Neon Company

Celebrating 50th Years, 1946-1996

NOTE: ILLUSTRATION IS AS ACCURATE AS POSSIBLE BASED ON INFORMATION PROVIDED. WORK IS FOR GENERAL ELEMENTS ONLY. DO NOT USE FOR FINAL ARCHITECTURAL

Building F - North Elevation
Scale 3/32" = 1' - 0"

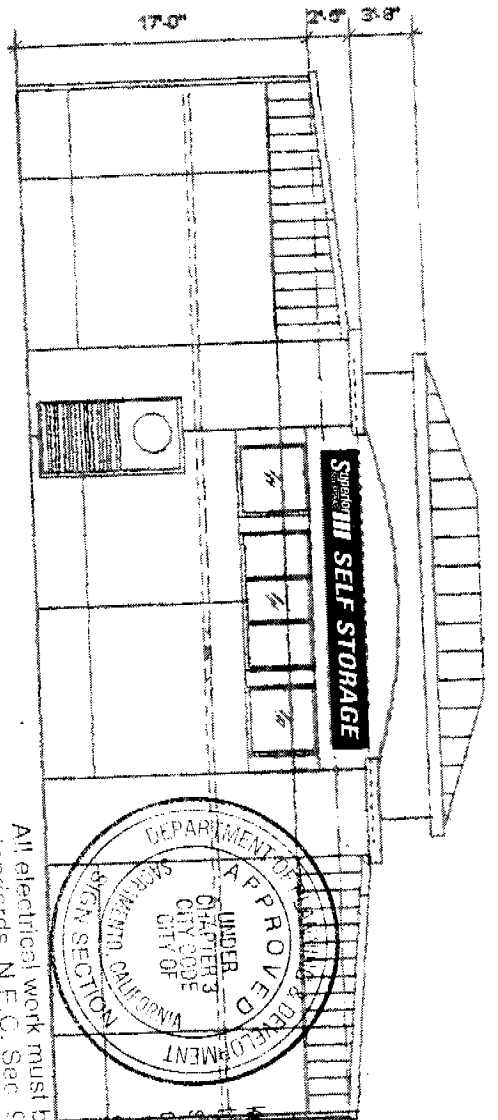

24"
Superior SELF STORAGE

1
17' - 0"

B S/F Illuminated Cabinet
Scale 3/8" = 1' - 0" THE APPROVAL OF ALL ELECTRICAL WORK IS SUBJECT TO FIELD INSPECTIONS.

S/F Illuminated Building Sign
1) Aluminum Extrusion Cabinet with Rout Faces Backed with White 015 SG Acrylic. Illuminate with Fluorescent Lamps. Background Painted Dark Green Matthews 22112, Satin Finish (Rb Roof Fern Green Ph. 909 875 8529)

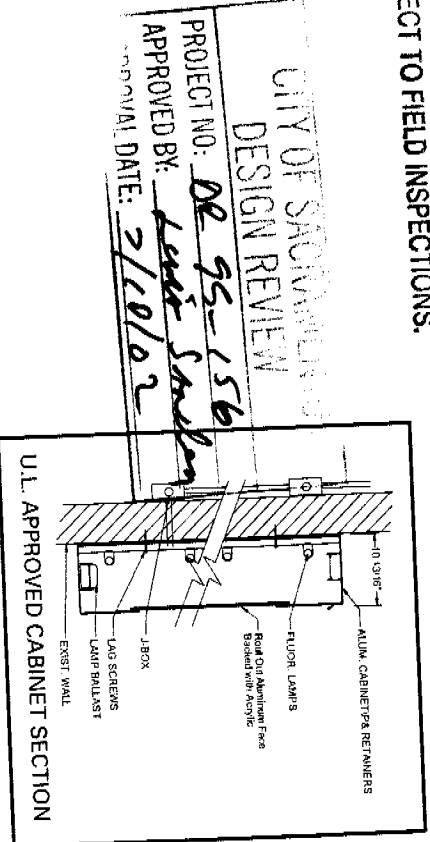

All electrical work must be U.L. listed and conform to all applicable standards, N.E.C. Sec. 90-Grand centrally within the City of Sacramento City Code. EQUIPMENT MUST BE U.L. LISTED AND BE SUBJECT TO FIELD INSPECTIONS ARE SUBJECT TO FIELD INSPECTIONS.

This set of plans and specifications is intended for the use of the contractor and is not to be used for any other purpose. The contractor shall be responsible for obtaining all necessary permits and approvals. The contractor shall be responsible for obtaining all necessary permits and approvals. The contractor shall be responsible for obtaining all necessary permits and approvals.

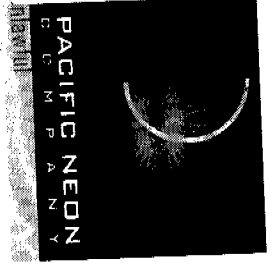

P.O. Box 15100
SACRAMENTO CA, 95851
PH: 916.927.0527
FAX: 916.927.2414
WWW.PACIFICNEON.COM
COPYRIGHT ©2002

Client: Superior Self Storage
Address: 1300 El Camino Avenue
Sacramento, CA

Account: Franz Deutsch
Project No: 02-7368
Date: 14 May 2002

| Revision | Date |
|----------|---------|
| A | 6.10.02 |
| B | |
| C | |

Client Approval: _____
Production Approval: _____

Drawing: _____

2





Typical Cabinet Display Installation

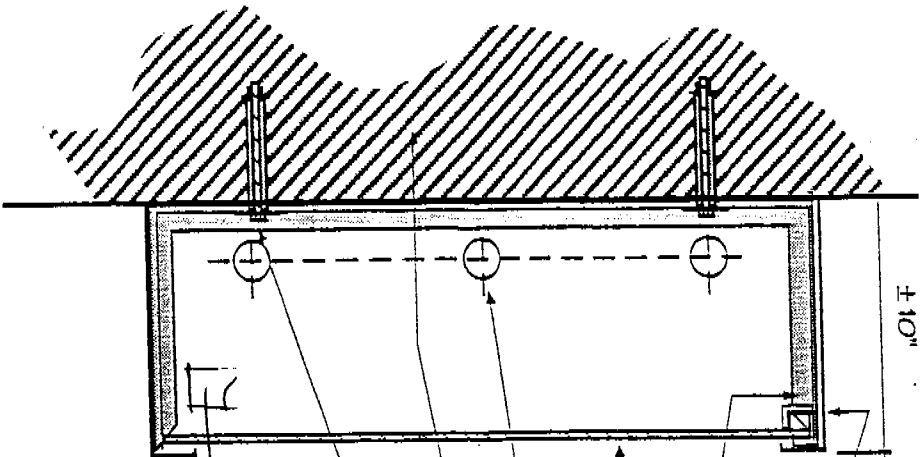

Disconnect

THE APPROVAL OF ALL ELECTRICAL WORK IS SUBJECT TO FIELD INSPECTIONS.

ILLUMINATED S/F CABINET INSTALLATION

SECTION DETAIL AT LEFT IS REPRESENTATIVE OF A TYPICAL ILLUMINATED CABINET DISPLAY INSTALLATION.

WALL MATERIAL AND/OR ELECTRICAL ACCESS MAY DIFFER FROM ILLUSTRATION.

PLEASE REFER TO ENCLOSED AND/OR ATTACHED DETAILS, ORIGINAL ARCHITECTURAL INFORMATION OR FIELD VERIFICATION FOR ACTUAL ON SITE WORKING CONDITIONS

Cabinet To Wall Attachment - Typical

Q1111: VARIOUS
DATE: 12 JULY 96

ATTN: 96-0000

LOC: VARIOUS

REF: 1 OF 1

NOTE: ILLUSTRATION IS AS ACCURATE AS POSSIBLE BASED ON INFORMATION PROVIDED. LAYOUT IS FOR GENERAL ELEMENTS ONLY. DO NOT USE FOR FINAL ARCHITECTURAL.

Calculating With Plans - 1946-1996

Pacific Neon Company

1516 SUI CA AVE., SHERMAN, CA 95901 • 916.827.0521 FAX 916.927.2114 ©1996