

CITY OF SACRAMENTO
1231 I Street
Sacramento, CA 95814

SIGN PERMIT

O.B.
U ZONE

PERMIT #: 9716071

JOB ADDRESS: 2595 CAPITAL OAKS DR

ASSESSORS PARCEL NO: 225-0230-080

DATE: 11/26/97

CONTRACTOR: PACIFIC NEON

OWNER: GOLDEN GATE UNIV.

PHONE #: 927 0527

PHONE #:

APPLICANT: PACIFIC NEON

DBA:

<input checked="" type="checkbox"/> ATTACHED	<input type="checkbox"/> INTERIOR / ELECT	<input type="checkbox"/> SINGLE FACED	(A) HEIGHT _____ (B) LENGTH _____
<input checked="" type="checkbox"/> ILLUMINATED	<input type="checkbox"/> NON-ILLUMINATED	<input type="checkbox"/> BILLBOARD / SUBDIVISION	(A X B) SIGN AREA 221 #
<input checked="" type="checkbox"/> INDIVIDUAL LETTERS	<input type="checkbox"/> PAINTED ON BUILDING	<input type="checkbox"/> LOGO	POLE SIZE _____ FOOTING SIZE _____
<input checked="" type="checkbox"/> METAL	<input type="checkbox"/> POLE	<input type="checkbox"/> DOUBLE FACED	STREET FRONTAGE (FT) _____
<input checked="" type="checkbox"/> PLASTIC	<input type="checkbox"/> MONUMENT	<input type="checkbox"/> VINYL / GATOR FOAM	OCCUPANCY FRONTAGE (FT) _____
<input type="checkbox"/> WOODEN	<input type="checkbox"/> PROJECTING	<input type="checkbox"/> RE-FACE	PUD _____
SIGN COPY: GOLDEN GATE UNIVERSITY			SIGN TAG #: 5-19761

Pa.# J4 11/26/97
\$75.00

CONSTRUCTION LENDING AGENCY

I hereby affirm under penalty of perjury that there is a construction lending agency for the performance of the work for which this permit is issued (Sec. 3097, Civ.C).

Lenders Name _____
Lenders Address _____

LICENSED CONTRACTORS DECLARATION

I hereby affirm under penalty of perjury that I am licensed under provisions of Chapter 9 (commencing with Section 7000) of Division 3 of the Business and Professions Code and my license is in full force and effect.

License Class C-10
License Number 303019 Date 11/26/97
Contractor Carl Cook (Signature)

OWNER - BUILDER DECLARATION

I hereby affirm under penalty of perjury that I am exempt from the contractors License Law for the following reason (Sec. 7031.5, Business and Professions Code: any city or county which requires a permit to construct, alter, improve, demolish, or repair any structure, prior to its issuance, also requires the applicant for such permit to file a signed statement that he or she is licensed pursuant to the provisions of the Contractors License Law (Chapter 9 (commencing with Section 7000) of Division 3 of the Business and Professions Code) or that he or she is exempt therefrom and the basis for the alleged exemption. Any violation of Section 7031.5 by any applicant for a permit subjects the applicant to a civil penalty of not more than five hundred dollars (\$500.00);

I, as a owner of the property, or my employees with wages as their sole compensation, will do the work, and the structure is not intended or offered for sale (Sec. 7044, Business and Professional Code: The Contractors Law does not apply to an owner of property who builds or improves thereon, and who does such work himself or herself or through his or her own employees, provided that such improvements are not intended or offered for sale. If, however, the building or improvement is sold within one year of completion, the owner-builder will have the burden of proving that he or she did not build or improve for the purpose of sale.)

I, as owner of the property, am exclusively contracting with licensed contractors to construct the project (Sec. 7044, Business and Professions Code: The contractors License Law does not apply to an owner of property who builds or improves thereon, and who contracts for such projects with a contractor(s) licensed pursuant to the Contractors License Law).

I am exempt under Sec. _____ Date _____
B & P C for this reason: _____
Owner _____ (Signature)

In issuing this building permit, the applicant represents, and the city relies on the representation of the applicant, that the applicant verified all measurements and locations shown on the application or accompanying drawings and that the improvement to be constructed does not violate any law or private agreement relating to permissible or prohibited locations for such improvements. This building permit does not authorize any illegal location of any improvement or the violation of any private agreement relating to location of improvements.

I certify that I have read this application and state that all information is correct. I agree to comply with all city and county ordinances and state laws relating to building construction and hereby authorize representatives of the city to enter upon the abovementioned property for inspection purposes.

11/26/97 Carl Cook (Signature of Applicant or Agent)

CITY OF SACRAMENTO
PAID \$1

WORKER'S COMPENSATION DECLARATION

I hereby affirm under penalty of perjury one of the following declarations: BUILDING INSPEC.

I have and will maintain a certificate of consent to self-insure for workers' compensation as provided for by Section 3700 of the Labor Code, for the performance of work for which the permit is issued.

I have and will maintain workers' compensation insurance, as required by Section 3700 of the Labor Code, for the performance of the work for which this permit is issued. My workers' compensation insurance carrier and policy number are:

Carrier STATE FUND
Policy Number 478-97

(This section need not be completed if the permit is for one hundred dollars (\$100) or less) I certify that in the performance of the work for which this permit is issued, I shall not employ any person in any manner so as to become subject to the workers' compensation laws of California and agree that if I should become subject to the workers' compensation provisions of Section 3700 of the Labor Code, I shall forthwith comply with those provisions.

Date 11/26/97 Applicant: Carl Cook (Signature)

WARNING: FAILURE TO SECURE WORKER'S COMPENSATION COVERAGE IS UNLAWFUL AND SHALL SUBJECT AN EMPLOYER TO CRIMINAL PENALTIES AND CIVIL FINES UP TO ONE HUNDRED THOUSAND DOLLARS (\$100,000) IN ADDITION TO THE COST OF COMPENSATION, DAMAGES AS PROVIDED FOR IN SECTION 3706 OF THE LABOR CODE, INTEREST AND ATTORNEY'S FEE.

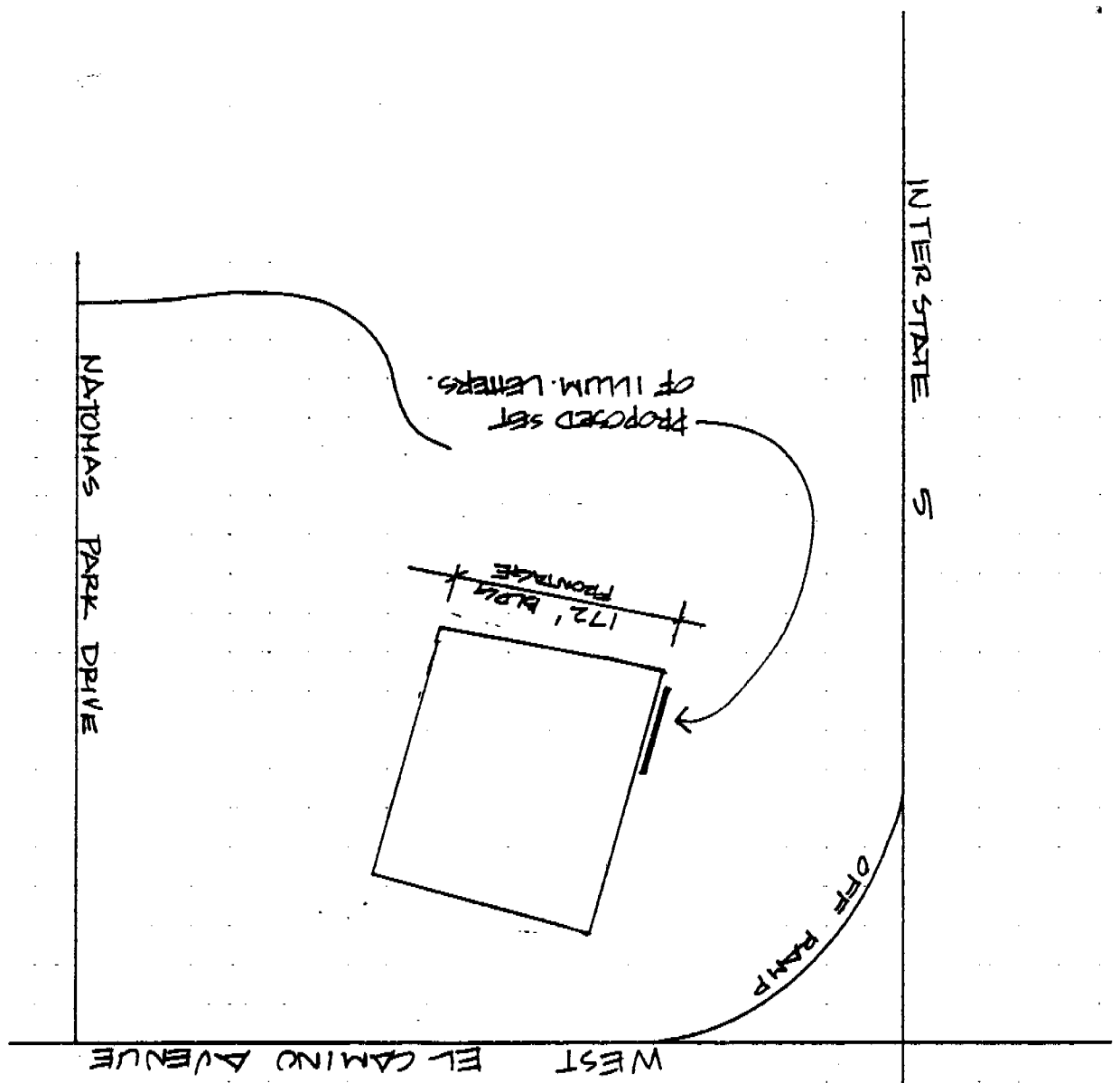



 SITE PLAN
 NO SCALE

FILE COPY

PacificNeonCompany

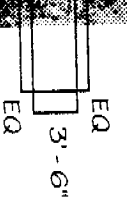

--- ALIGN



ILLUMINATED LETTERS

PRELIMINARY 8 OCTOBER 1997
 SHOP DRAWING 5 NOVEMBER 1997
 REVISED SHOP DRAWING 14 NOVEMBER 1997

SCALE: 1/8" = 1'-0"

SPECIFICATIONS:
 FABRICATE AND INSTALL ONE (1) SET
 OF HALO ILLUMINATED LETTERS

LETTERS:
 3" ALUMINUM RETURNS WITH CLEAR
 POLYCARBONATE (LEXAN) BACKS,
 RETURNS PAINTED TO MATCH
 PANTONE 647 BLUE, GLOSS FINISH

**FACES TO BE ALUMINUM PAINTED
 TO MATCH PANTONE 647 BLUE
 GLOSS FINISH.**

**ILLUMINATION:
 15MM WHITE NEON 30MA**

NOTE:
 VERIFY ALL DIMENSIONS

This set of plans and specifications must be kept on the job at all times and it is unlawful to make any changes or alterations from the same without written permission from the City of Sacramento Sign Section.

The approval of this plan and specification SHALL NOT be held to permit or approve the violation of any city ordinance or state law.

All electrical work must be U.L. labeled or be of equivalent standards, N.E.C. Sec. 90-6/and comply with chapter 14, Div. 2 of Sacramento City Code.

**EQUIPMENT MUST BE USED AS DESIGN INTENDED
 ALL SIGN INSTALLATIONS ARE SUBJECT TO FIELD INSPECTIONS**

2595

LIUMI: CAPITAL OAKS DRIVE, SACRAMENTO, CA

MR: 10F1

1515 SIDA AVE., SACRAMENTO, CA 95815 - 916 927 0527 FAX 916 927 2414 ©1997

PacificNeonCompany

Specialties & Solutions SINCE 1948
 NOTE: THIS DRAWING IS PRELIMINARY FOR GRAPHIC ELEMENTS AND NOT INTENDED FOR ACTUAL FABRICATION. FABRICATION TECHNIQUES VARY AND CHANGES MAY OCCUR. ILLUSTRATION IS AS ACCURATE AS POSSIBLE BASED ON INFORMATION PROVIDED.

3'-6"
GOLDEN GATE UNIVERSITY
 FILE COPY

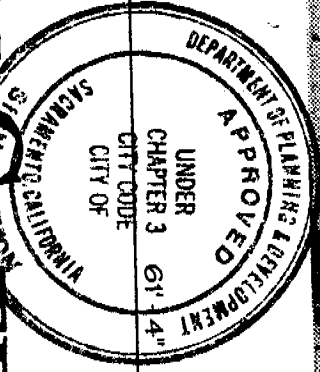

LIUMI: GOLDEN GATE UNIVERSITY
 ACUMI: GARY YUKE 97-1446
 MII: 8 OCTOBER 1997 / 5 NOVEMBER 1997 / 14 NOVEMBER 1997



Typical Halo Letter / PK Installation

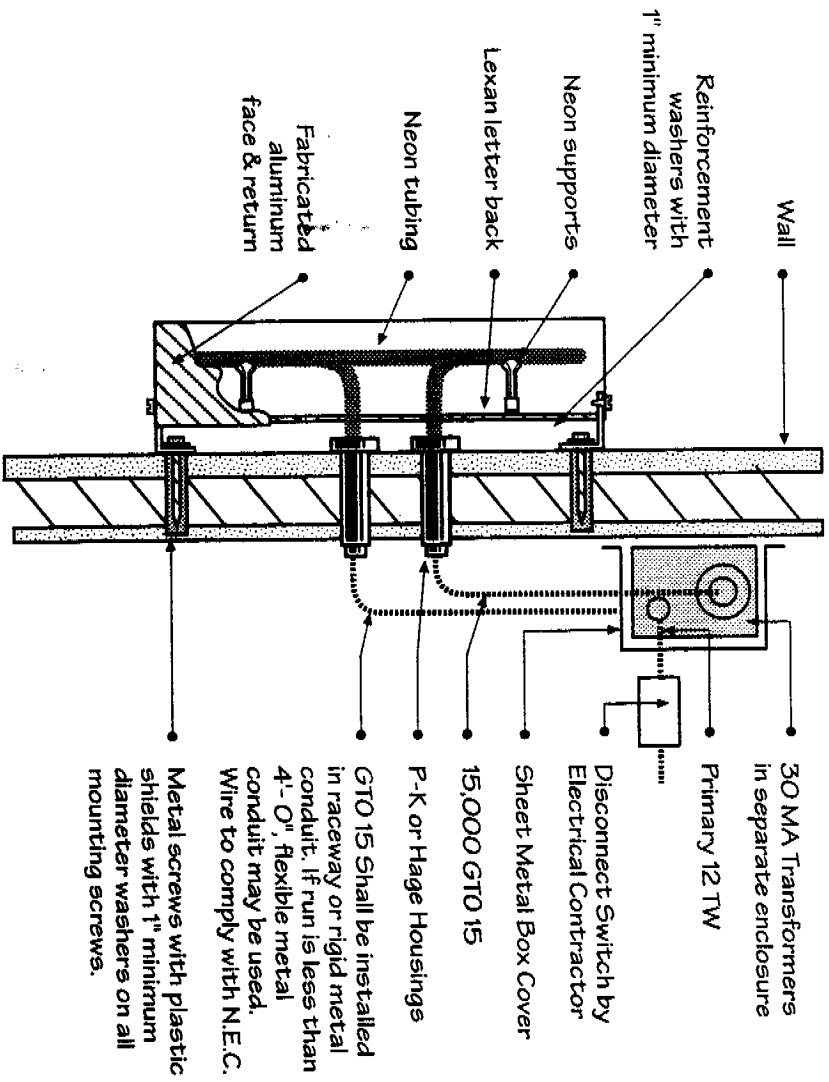

ILLUMINATED HALO LETTER PK INSTALL

NOTE: Section drawing at left represents a typical UL approved installation of a standard neon illuminated channel letter.

Wall or fascia material and/or actual electrical access may differ from that depicted in illustration.

Please refer to enclosed details, original architectural information, as built data, or field verification for actual on site working conditions.

Individually Illuminated Halo Letter with P-K Housings

ULIII: VARIOUS
DATE: 30 JULY 96

ACTUUM: 96-0000

ULIUM: VARIOUS

DATE: 1 OF 1

NOTE: ILLUSTRATION IS AS ACCURATE AS POSSIBLE BASED ON INFORMATION PROVIDED. LAYOUT IS FOR GRAPHIC ELEMENTS ONLY. DO NOT USE FOR FINAL MEASUREMENTS.

Celebrating 75th Years, 1916-1995

Pacific Neon Company

1575 SUICAWAY, SACRAMENTO, CA 95816 • 916.927.0527 FAX 916.927.2414 © 1995

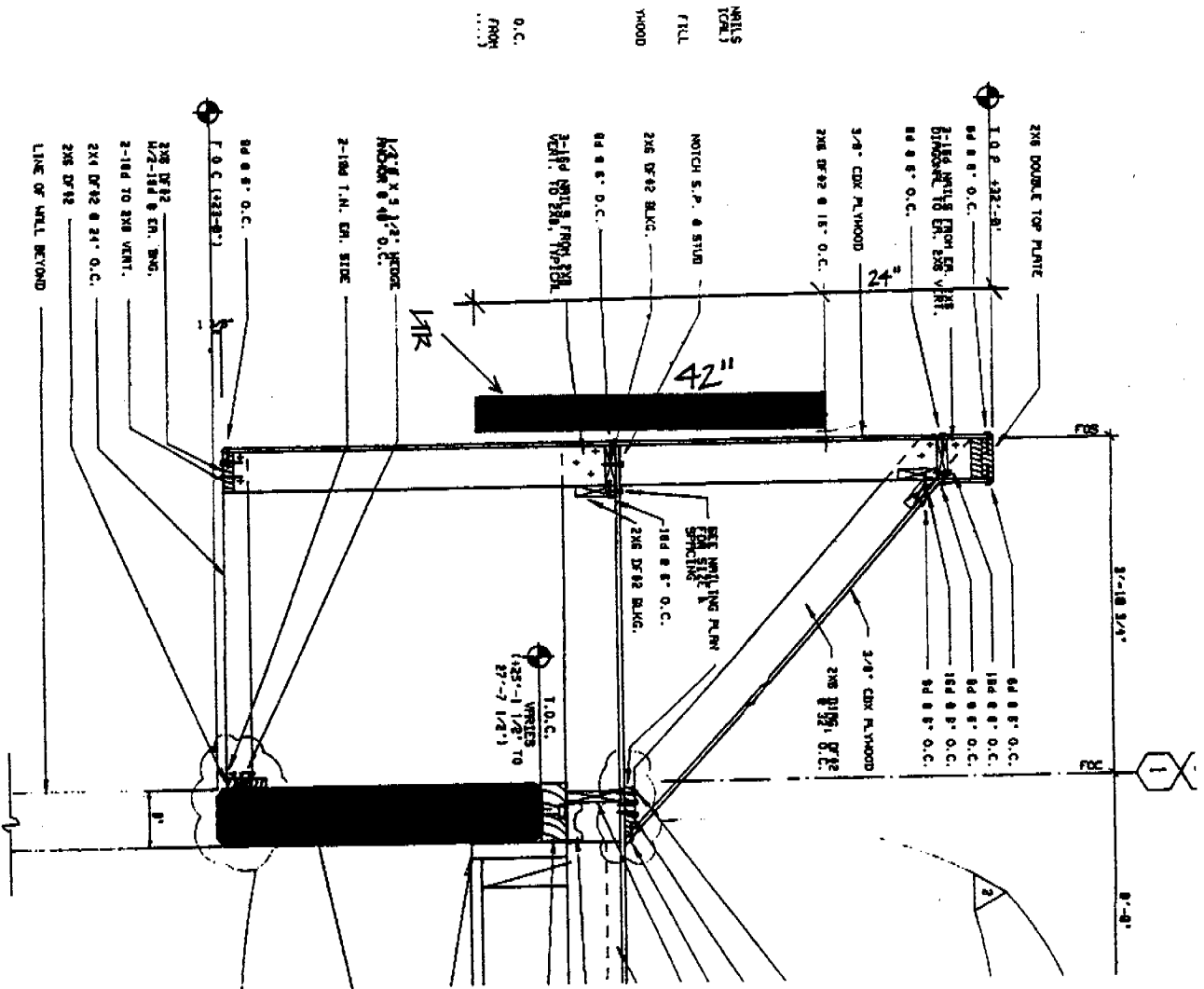

NAILS
 (TOP &
 FROM
 O.C.
 FROM
 ...

PacificNeonCompany