

CITY OF SACRAMENTO

Permit No: 9803778

1231 I Street, Sacramento, CA 95814

Insp Area: 2

Site Address: 5330 REXLEIGH DR SAC

Sub-Type: NSFR

Parcel No: 1171240004

Housing (Y/N): N

CONTRACTOR

CALIFORNIA HOMES
3031 W. MARCH LANES #133 s
STOCKTON 95219

OWNER

R E DEVELOPMENT CORPOR
3031 W MARCH LN 133-S
STOCKTON CA 95219

ARCHITECT

Nature of Work: NEW SINGLE FAMILY DWELLING UNIT- MP # 1704 - 7 ROOMS

CONSTRUCTION LENDING AGENCY : I hereby affirm under penalty of perjury that there is a construction lending agency for the performance of the work for which this permit is issued (Sec. 3097, Civ. C).

Lender's Name Lender's Address

LICENSED CONTRACTORS DECLARATION: I hereby affirm under penalty of perjury that I am licensed under provisions of Chapter 9 (commencing with section 7000) of Division 3 of the Business and Professions Code and my license is in full force and effect.

License Class B License Number 488794 Date 3/31/2000 Contractor Signature [Signature]

OWNER-BUILDER DECLARATION: I hereby affirm under penalty of perjury that I am exempt from the contractors License Law for the following reason (Sec. 7031.5, Business and Professions Code; any city or county which requires a permit to construct, alter, improve, demolish, or repair any structure, prior to its issuance, also requires the applicant for such permit to file a signed statement that he or she is licensed pursuant to the provisions of the Contractors License Law (Chapter 9 (commencing with Section 7000) of Division 8 of the Business and Professions Code) or that he or she is exempt therefrom and the basis for the alleged exemption. Any violation of Section 7031.5 by any applicant for a permit subjects the applicant to a civil penalty of not more than five hundred dollars (\$500.00);

I, as a owner of the property, or my employees with wages as their sole compensation, will do the work, and the structure is not intended or offered for sale (Sec. 7044, Business and Professional Code: The Contractors License Law does not apply to an owner of property who builds or improves thereon, and who does such work himself or herself or through his/her own employees, provided that such improvements are not intended or offered for sale. If, however, the building or improvement is sold within one year of completion, the owner-builder will have the burden of proving that he/she did not build or improve for the purpose of sale.)

I, as owner of the property, am exclusively contracting with licensed contractors to construct the project (Sec. 7044, Business and Professions Code: The Contractors License Law does not apply to an owner of property who builds or improves thereon, and who contracts for such projects with a contractor(s) licensed pursuant to the Contractors License Law).

I am exempt under Sec. B & PC for this reason:

Date Owner Signature

IN ISSUING THIS BUILDING PERMIT, the applicant represents, and the city relies on the representation of the applicant, that the applicant verified all measurements and locations shown on the application or accompanying drawings and that the improvement to be constructed does not violate any law or private agreement relating to permissible or prohibited locations for such improvements. This building permit does not authorize any illegal location of any improvement or the violation of any private agreement relating to location of improvements.

I certify that I have read this application and state that all information is correct. I agree to comply with all city and county ordinances and state laws relating to building construction and hereby authorize representative(s) of this city to enter upon the above mentioned property for inspection purposes.

Date 6/17/98 Applicant/Agent Signature [Signature]

WORKER'S COMPENSATION DECLARATION: I hereby affirm under penalty of perjury one of the following declarations:

I have and will maintain a certificate of consent to self-insure for workers' compensation as provided for by Section 3700 of the Labor Code, for the performance of work for which the permit is issued.

I have and will maintain workers' compensation insurance, as required by Section 3700 of the Labor Code, for the performance of the work for which this permit is issued. My workers' compensation insurance carrier and policy number are:

Carrier Golden Eagle Policy Number NWC:476870-00

(This section need not be completed if the permit is for \$100 or less) I certify that in the performance of the work for which this permit is issued, I shall not employ any person in any manner so as to become subject to the workers' compensation laws of California and agree that if I should become subject to the workers' compensation provisions of Section 3700 of the Labor Code, I shall forthwith comply with those provisions.

Date 6/17/98 Applicant Signature [Signature]

WARNING: FAILURE TO SECURE WORKER'S COMPENSATION COVERAGE IS UNLAWFUL AND SHALL SUBJECT AN EMPLOYER TO CRIMINAL PENALTIES AND CIVIL FINES UP TO ONE HUNDRED THOUSAND DOLLARS (\$100,000) IN ADDITION TO THE COST OF COMPENSATION, DAMAGES AS PROVIDED FOR IN SECTION 3706 OF THE LABOR CODE, INTEREST AND ATTORNEY'S FEE.

THIS PERMIT SHALL EXPIRE BY LIMITATION IF WORK IS NOT COMMENCED WITHIN 180 DAYS.

ENGEL INSULATION, INC.

CALIFORNIA CONTRACTOR'S LICENSE #745646

460 Roseville Road • Roseville, CA 95678

(916) 786-2088 / (916) 969-6191

THIS IS TO CERTIFY THAT INSULATION HAS BEEN INSTALLED IN CONFORMANCE WITH CURRENT ENERGY REGULATIONS. CALIFORNIA ADMINISTRATIVE CODE, TITLE 24, STATE OF CALIFORNIA, IN THE BUILDING LOCATED AT:

TRACT _____ LOT 41174
STREET _____ CITY ROSEVILLE

EXTERIOR WALLS:

MANUFACTURER _____ THICKNESS 2 1/2" R-VALUE 13

CEILING AREA: BATTS

MANUFACTURER _____ THICKNESS 1 1/2" R-VALUE 7

CEILINGS: BLOWN IN

MANUFACTURER _____ THICKNESS _____ R-VALUE _____

SQUARE FOOTAGE _____ NUMBER OF BAGS USED _____

FLOOR AREA:

MANUFACTURER _____ THICKNESS _____ R-VALUE _____

EXTERIOR KNEEWALL:

MANUFACTURER _____ THICKNESS _____ R-VALUE _____

INTERIOR KNEEWALL:

MANUFACTURER _____ THICKNESS _____ R-VALUE _____

APPLIED CAULK & SEALANT TO ALL EXTERIOR
OPENINGS & PENETRATIONS

YES _____ NO _____

GENERAL CONTRACTOR _____
CALIFORNIA CONTRACTORS
LICENSE # _____

DATE _____

SIGNATURE _____

DATE _____

INSULATION CONT SIGNATURE _____

TITLE _____

DATE _____

COUNTY SANITATION DISTRICT NO. 1
 SACRAMENTO REGIONAL COUNTY SANITATION DISTRICT
SEWER IMPACT FEE
 PERMIT AND CALCULATION SHEET

APPLICATION NO: _____

BLDG PERMIT NO: _____

GENERAL INFORMATION

THIS PERMIT GOOD ONLY WHEN
 VALIDATED BY THE CASHIER

THIS PERMIT TO CONNECT EXPIRES
 ONE YEAR FROM DATE OF ISSUANCE

FEE CALCULATION		BUILDING USE	
INSPECTION		RESIDENTIAL	SF <input type="checkbox"/> MF <input type="checkbox"/>
CSD-1		COMMERCIAL USE	UNITS
SRCSD			
CONSTRUCTION			
IN-LIEU			
TOTAL FEE			

APN: _____

DESCRIPTION/
 SUBDIVISION

LOT _____

PROPERTY ADDRESS

OWNER

MAILING ADDRESS

CITY-STATE-ZIP

PHONE _____

ADDITIONAL FEES MAY BE DUE OR CHARGED. IN EFFECT REPLACEMENT SEWER IMPACT _____

APPLICANT SIGNATURE _____

CONSOLIDATED UTILITY BILLING FEE (MUT) _____

ACCT _____

DATE _____

BY _____

Certification of Compliance

School District Development Fees

(Print or Type) If Printing, press hard for four copies

PART I To be completed by the APPLICANT

OWNER'S NAME _____

OWNER'S ADDRESS _____

PROJECT ADDRESS _____

PARCEL NUMBER _____ LOT NO. _____

SUBDIVISION NAME _____

NUMBER OF UNITS _____

Upon payment of the fees listed below, a 90-day approval period commences upon which the applicant paying the fees may protest such fees. Any failure to file such protest within the 90-day period shall result in forfeiture of any rights to challenge such fees, through litigation or otherwise.

APPLICANT'S SIGNATURE _____

TITLE OF APPLICANT _____

DATE _____ PHONE NUMBER _____

PART II To be completed by BUILDING DEPARTMENT

PLAN IDENTIFICATION NUMBER _____

BUILDING TYPE _____

RESIDENTIAL () APARTMENT/CONDOMINIUM () COMMERCIAL/INDUSTRIAL ()

SQUARE FEET OF CHARGEABLE BUILDING AREA _____

SIGNATURE _____

TITLE _____ DATE _____

PART III To be completed by SCHOOL DISTRICT

SCHOOL DISTRICT _____

DISTRICT CERTIFICATION NO. _____

EXEMPT	COMMENTS	
--------	----------	--

RESIDENTIAL APT/CONDO	SQ FT X \$	= \$
-----------------------	------------	------

COMMERCIAL/INDUSTRIAL	SQ FT X \$	= \$
-----------------------	------------	------

OTHER FEE TYPE	SQ FT X \$	= \$
----------------	------------	------

TOTAL FEES COLLECTED	= \$
----------------------	------

This Certification covers only the amount of square footage indicated above. Any additions or corrections to the square footage for this project will require an amendment to the Certificate of Compliance.

As the authorized school district official, I hereby certify that the requirements of Government Code Section 65995 and any other authorized requirements have been complied with by the above signed applicant.

AUTHORIZED SCHOOL DISTRICT OFFICIAL

PAID

SIGNATURE _____

TITLE _____ DATE _____

Original: School District 1st copy: School District 2nd copy: Building Department 3rd copy: Applicant

PP-1 A

CITY OF SACRAMENTO
DEPARTMENT OF PLANNING AND DEVELOPMENT
BUILDING INSPECTIONS DIVISION

1231 I Street • Room 200 • Sacramento, CA 95814 • Phone (916)264-7619

**SCHOOL DISTRICT
MASTER PLAN FILE**

CONTRACTOR CALIFORNIA HOMES

SUBDIVISION NAME ARLINGTON PK CREEKSIDE #4 APN # 117-124-004

CONTRACTOR LIC. NO. _____ PLAN NO. 1704

SINGLE FAMILY DUPLEX _____ HALF PLEX _____ ROW HOUSE _____

0 LOT LINE _____

SQUARE FEET OF HABITABLE AREA 1704

SCHOOL DISTRICT E.G. U.S.D.

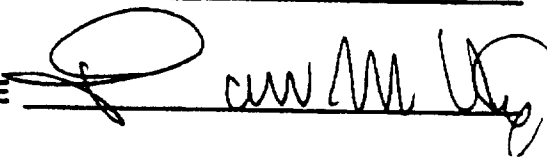
AUTHORIZED SIGNATURE 

TITLE B.I. III

DATE 12-6-95



INSTALLATION CARD
WESTERN ONE KOTE STUCCO SYSTEM
WESTERN STUCCO PRODUCTS CO. INC.



Address _____

ICBO Evaluation Service, Inc.
Report No. 3899

Date of Job Completion _____

Plastering Contractor

Name BERNARD LATH AND PLASTERING

Address: 10041 S. PRIEST RD FRENCH CAMP, CALIF 95231

Telephone Number (209) 982-4607

Approved Contractor License Number as
issued by Western Stucco Products #352

This is to certify that the plastering system on the building exterior at the above address has been installed in accordance with the evaluation report specified above and the manufacturer's instructions.

[Signature]
Signature of authorized representative of plastering contractor

_____ Date

This card must be presented to the building inspector after completion of work and before final inspection.

NO 001247

FIGURE NO. 3



ICBO Evaluation Service, Inc.

5360 WORKMAN MILL ROAD • WEATHER, CALIFORNIA 90721-2090

A subsidiary corporation of the International Conference of Building Officials

EVALUATION REPORT

Copyright © 1997 ICBO Evaluation Service, Inc.

ER-400

Reissued May, 1998

Filing Category: EXTERIOR COATINGS (1060)

OMEGA DIAMOND WALL, THORO ONE COAT, AND SENERGY ONE COAT INSULATING EXTERIOR STUCCO SYSTEMS

OMEGA PRODUCTS INTERNATIONAL, INC.
282 SOUTH ANITA
ORANGE, CALIFORNIA 92666

HARRIS SPECIALTY CHEMICALS INC.
10245 CENTURION PARKWAY NORTH
JACKSONVILLE, FLORIDA 32256

1.0 SUBJECT

Omega Diamond Wall, Thoro One Coat, and Senergy One Coat Insulating Exterior Stucco System

2.0 DESCRIPTION

2.1 General

The Omega Diamond Wall, Thoro One Coat, and Senergy One Coat Insulating Exterior Stucco Systems are proprietary mixtures of portland cement, sand, fibers, water, and proprietary ingredients reinforced with wire fabric or lath and applied to substrates of gyp panel, polystyrene (EPS) insulation board, Fome One board, structural panels, fiberboard, and gypsum sheathing. The systems are installed on exterior walls of wood or steel stud construction.

2.2 Materials

2.2.1 Concentrate. A factory prepared mixture of type I portland cement complying with ASTM C 150, type III or Type IV portland cement, and proprietary additives. The mixture is packaged in 80 pound net weight bags. Approximately 1 1/2 bags (117 to 200 lbs.) of concentrate and two 160 and 200 gallon (15.7 and 24.3 gallon) buckets product 100 and 91.5 (109 kg) of sand are added to each bag on the field and mixing is done in accordance with manufacturer's recommendations. As an alternate to the Diamond Wall PM system, approval is granted for the Omega Diamond Wall PM Admix 500 (see half of the water required). The Diamond Wall PM system requires the proportions specified in Section 2.2.1 of this report.

2.2.2 Sand. Must be clean and free from deleterious amounts of loam, clay, silt, soluble salts and organic matter. Sampling and testing must comply with ASTM C 143 or C 897. Sand must be graded according to ASTM C 143 or C 897, and is shown in the following table:

RETAINED ON U.S. STANDARD SIEVE	PERCENT RETAINED BY WEIGHT (2 Percent)	
	Min	Max
75	0	5
150	0	10
300	0	15
600	0	25
1000	0	40
2000	0	75
425	100	100

2.2.3 Insulation Board

2.2.3.1 Expanded Polystyrene (EPS) Insulation Board. EPS board has a nominal density of 1.5 pounds per cubic foot (24 kg/m³), Class I flame spread rating and a smoke developed rating not to exceed 10. It must comply with ASTM C 120, thickness 1 1/2 to 2 1/2 inch and reinforced with galvanized wire fabric or lath complying with code and approved for use on panels. See Figure 1 for wall details. EPS boards must have manufacturer's approval and be certified by ICC-ES or the National Evaluation Service. See Section 2.6 for board identification.

2.2.3.2 Extruded Polystyrene (XEPS) Insulation Board. The board has a minimum nominal density of 1.5 pounds per cubic foot (24 kg/m³). See Section 2.1.5.1 for other details and requirements.

2.2.3.3 Fome-Cor Fume One board is described in Evaluation Report ER-3336.

2.2.4 Lath

2.2.4.1 Wire Fabric Lath. Minimum No. 20 gage 1 inch (25 mm) galvanized steel woven wire fabric lath must be self-lathing or lathed when applied over all substrates except extruded polystyrene board. Self-lathing lath for coating must comply with the following requirements:

1. The maximum lath coating thickness shall be 1/4 inch.
2. Furring strips, must be provided at a maximum of 12 inches (305 mm) wide at each bay. The spacing must be perpendicular to the panel, and must be 2 mm minimum from the surface of the installation.

2.2.4.2 Metal Lath. Lath per ASTM Tech. 12-B for the code, flange and self-lathing requirements are as set forth in wall detail lath.

2.2.5 Gypsum Sheathing Board. Water resistant gypsum sheathing complying with ASTM C 139.

2.2.6 Fiberboard. Minimum 5/8 inch thick (16 mm) asphalt or preglazed fiberboard complying with ANSI A-194.1 or large fiber density sheathing.

2.2.7 Wood Structural Panels. Minimum 5/8 inch thick (16 mm) panels with exterior glue for studs spaced 16 inches (406 mm) on center and minimum 3/8 inch thick (9.5 mm) panels with exterior glue for studs spaced 24 inches (610 mm) on center. Plywood complying with IRC Standard 23.2. Oriented strand board complying with IRC Standard 23.3.

2.2.8 Caulking. Acrylic latex caulking must comply with ASTM C 844.

2.2.9 Weather resistive Barrier. Minimum Grade D kraft barrier paper complying with IRC Standard 14.1.1 or asphalt saturated felt complying with UL Standard Specification 55-A-1983 is required. The weather resistive barrier is placed over all substrates except EPS board where the barrier may be attached to the board. Asphalt felt of the barrier complies with Section 14.1.1 of the code. When applied over any wood based sheathing, the barrier must be a minimum two layers of Grade D barrier paper as set forth in Section 14.1.1 of the code.

Evaluation reports of ICBO Evaluation Service, Inc. are issued solely to provide information to Class A members of ICBO, utilizing the code upon which the report is based. Evaluation reports are not to be construed as representing aesthetics or any other attributes not specifically addressed nor as an endorsement or recommendation of the subject report.

This report is based upon independent tests or other technical data submitted by the applicant. The ICBO Evaluation Service, Inc. is not liable for the results of the tests.

tion 2506.4 of the code, or one layer of EPS or XEPS as described in Section 2 2 3.1 or 2 2 3.2 over one layer of Grade D building paper having a minimum water resistance of 60 minutes.

2 2 10. Fibers: Glass fibers, Type E, 1 1/2 inch (37 mm) long or 3/8 inch (9.5 mm) BASF aramid fibers for short term benefits during installation.

2 2 11. Admixtures: Proprietary pigments included to improve quality of coating mixture.

2 2 12. Miscellaneous: All four corners and corner reinforcement must be galvanized steel or approved plastic.

2 3. Installation

2 3 1. General: The exterior cementitious coating is applied by hand troweling or machine spraying in one coat to a minimum 3/8 inch (9.5 mm) thickness. The lath must be embedded in the final coating thickness and therefore cannot be exposed. Concrete water based paint may be applied after 48 hours of curing in shade and dry part after 10 days of curing. Fasteners for lath are placed at a minimum of 1 inch (25 mm) into wood framing. Flashing and corner reinforcement materials and weep screeds must be installed according to the attached details. See Figure 2. The coating is applied at ambient air temperatures ranging from 40°F to 110°F (4°C to 43°C) on applicators approved by Omega Products International, Inc. (Omega Specialty Chem Systems). The weather resistive barrier is not applied as set forth in Section 2 2 9. An installation card as noted in Figure 2 must be on the jobsite with the name of the applicator and the product to be used before any weather resistive barrier or exterior sheathing is installed. Also see Section 4.6 of this report.

2 3 2. Application over Open Framing

2 3 2.1. EPS and XEPS Insulation Board: The weather-resistive barrier is placed over open studs spaced 24 inches (610 mm) on center, maximum. The EPS or XEPS board described in Section 2 2 3.1 or 2 2 3.2 is then placed with galvanized staples or roofing nails. Vertical butt joints must be staggered at least one stud space between adjacent courses and must occur directly over studs.

The lath is then applied tightly over the polystyrene board and fastened through the board to wood studs using No. 11 gage galvanized roofing nails No. 16 gage staples spaced 6 inches (152 mm) on center with a minimum 1 inch (25 mm) penetration. Staples must have a minimum crown width of 1/8 inch (3.1 mm). For staple spacing with various wood species and staple gages, see Table 3. Care must be taken to avoid overdriving fasteners. The Omega One Coat Wall Three Coat and Sengry One Coating system may also be applied to minimum No. 20 gage (0.0359 inch (0.91 mm)) steel studs spaced 24 inches (610 mm) on center. No. 20 gage (0.0359 inch (0.91 mm)) wall lath is applied tightly over the polystyrene board and is fastened through the board and weather-resistive barrier to the metal studs with minimum No. 8 screws having a 3/8 inch (9.5 mm) pan head at 7 inches (178 mm) on center to an edge and track. The lath is applied with 2 inch (51 mm) end and side gaps. Screws must penetrate the studs a minimum of 1/2 inch (12.7 mm). Wall bracing in accordance with Section 2326.11.3 or 2326.11.4 of the code, or an approved alternate, is required. Square wall corners and parapet corners are covered with metal corner reinforcement. For round wall, butt, nose and parapet corners, metal reinforcement is optional when construction is according to Figure 2. Weep screeds are installed when construction is in accordance with Section 2506.5 of the code. Galvanized steel 1 1/2 inch (38 mm) J shaped trim pieces are installed at other areas where beams are exposed. All windows and doors flashing described are installed according to Section 1402.2 of the code is required. Butting, caulking and approved metal edges must be caulked. Holes for pipes, electrical panels and other penetrations of substrate surfaces, except those caused by fasteners, must also be caulked. The coating is applied after caulking as described in Section 2 3 1.

2 3 2.2. Fome Cor Board: The Fome Cor board is applied in accordance with Section 2 2 3.1 or 2 2 3.2 of the code.

through the Fome Cor to the studs with 1 inch crown (25 mm) No. 16 gage staples, or, of sufficient leg length, to penetrate studs a minimum of 1 inch (25 mm). The coating is applied as described in Section 2 3 1 to a minimum 3/8 inch (9.5 mm) thickness. Alternately, the base coat is a minimum 1/4 inch thick (6.35 mm) and is cured according to Section 2 2 3. The minimum 1/8 inch finish coat is then applied over the cured base coat. Additional installation requirements are as noted in Section 2 3 2.1.

2 3 3. Application over Solid Backing

2 3 3.1. Fiberboard: Minimum 1/2 inch thick (12.7 mm) fiberboard is installed directly to wood studs spaced 24 inches (610 mm) on center, maximum. The fiberboard is temporarily held in place with corrosion-resistant staples or roofing nails. Two layers of Grade D building paper or one layer of EPS or XEPS as described in Section 2 2 3.1 or 2 2 3.2 over one layer of Grade D building paper having a minimum water resistance of 60 minutes is applied over the fiberboard before the lath. The lath is then attached to the studs through the sheathing with fasteners and coatings described in Section 2 3 2.1 with the exception of Table 3.1.0 of the code, which never shall be used. All wall joints shall be in accordance with the code. Exposed sheathing edges are protected with screeds. Holes in the substrate surface are caulked and the coating applied in accordance with Section 2 3 1. The fiberboard lath and coating may be applied to minimum No. 20 gage (0.0359 inch (0.91 mm)) steel studs spaced 24 inches (610 mm) on center, maximum, provided the fasteners and attachment are as set forth in Section 2 3 2.1 for steel studs.

2 3 3.2. Gypsum Sheathing: Minimum 1/2 inch thick (12.7 mm) water-resistant core gypsum sheathing is installed directly over wood studs spaced 24 inches (610 mm) on center, maximum. Gypsum sheathing is fastened in accordance with Table 25.6 of the code. A weather-resistive barrier is applied over the gypsum sheathing before lath or optional insulation board. The lath is then attached to studs through the sheathing with fasteners and coatings as described for insulation board in Section 2 3 2 of this report. All wall joints must be braced in accordance with the code. Exposed sheathing edges are protected with screeds. Holes in the substrate surface are caulked and the coating applied as described in Sections 2 3 1 and 2 3 2.

Application to minimum No. 20 gage (0.0359 inch (0.91 mm)) steel studs at a maximum of 24 inches (610 mm) on center is permitted, provided No. 8 gage, Type S, drywall screws with 1 inch diameter (25 mm) washer for No. 8 self-tapping, pan head screws with a minimum 3/8 inch (9.5 mm) head diameter is installed at the same spacing as nails or staples in wood studs.

2 3 3.3. Wood Structural Panels: Panels are applied directly to wood studs under the conditions set forth in Section 2 2 7 of the report and Table 23.1.1.1 of the code. The weather-resistive barrier, wire fabric lath and coating are applied as described in Section 2 3 3.1 for fiberboard. Fasteners to minimum No. 20 gage (0.0359 inch (0.91 mm)) steel studs spaced 24 inches (610 mm) on center, maximum, is also as described in Section 2 3 3.1 for fiberboard.

2 4. One-hour Fire-resistive Assembly

2 4 1. First Assembly

2 4 1.1. Interior Face: One layer of 5/8 inch thick (15.9 mm) Type X wallboard, water-resistive barrier board or steel base is applied parallel to or at right angles to the interior face of 2 by 4 wood studs spaced 24 inches (610 mm) on center, maximum. The wallboard is attached with Gd coated nails 1 1/4 inches (38 mm) long with 1/2 inch diameter (12.7 mm) heads, at 7 inches (178 mm) on center to studs, plates and blocking. All wallboard joints must be backed with minimum 2 by 4 wood framing lathed and treated with joint compound. Fastener heads must also be treated with joint compound.

2 4 1.2. Exterior Face: One layer of minimum 5/8 inch thick (15.9 mm) Type X water-resistant core gypsum sheathing 48 inches (1219 mm) wide is applied parallel to studs with No. 11 gage galvanized

nated to top and bottom plates at 6 inches (152 mm) on center. A weather-resistant barrier is required over the sheathing. The lath and wall coating are then applied as described in Section 2.3.2.

2.4.2 Second Assembly

2.4.2.1 Interior Face One layer of 5/8 inch-thick (15.9 mm) Type X gypsum wallboard is applied horizontally to the interior face of wood studs spaced 16 inches (406 mm) on center in a running bond. The wallboard is fastened to studs with 5/8 gypsum wallboard nails having a minimum 11/64-inch diameter (6 mm) heads at 8 inches (203 mm) on center to studs, plates and sills. All wallboard joints must be backed with minimum 2-by-4 wood framing taped and treated with joint compound. Fastener heads must also be treated with joint compound. Mineral wool insulation (bat) R-13, 3 5/8 inches (92 mm) thick and having a minimum 1.97 pcf (31.56 kg) density, are placed in the cavities between studs, and secured to studs.

2.4.2.2 Exterior Face A weather-resistant barrier is applied over the exterior face of wood studs in accordance with Section 2.2.4. One inch-thick (25 mm), 1.5 pcf (24 kg/m³) density EPS board is applied in accordance with Section 2.3.2, followed by 1 inch (25 mm) by No. 20 gage woven wire lath. The lath is fastened through the EPS board to studs and plates with No. 11 gage galvanized roofing nails, 2 inches (51 mm) long and having 3/8-inch diameter (9.5 mm) heads at 6 inches (152 mm) on center. Lath overlaps are a minimum of 2 inches (51 mm). The Diamond Wall mixture, with glass fibers, and is then applied to the lath in accordance with Section 2.3.1.

2.5 Noncombustible Construction

With foam plastic, the studs system may be installed as follows. In exterior walls required to be noncombustible construction:

2.5.1 Interior Finish One layer of 5/8 inch-thick (15.9 mm) Type X gypsum wallboard, complying with ASTM C 36, is applied vertically to steel framing with all edges blocked. Fasteners are No. 8 by 1 1/2 inch long (32 mm) bugle head screws fastened to board joints at 8 inches (203 mm) on center and intermediate locations at 12 inches (305 mm) on center. All joints are taped and treated with joint compound. Intermediate fasteners are treated with compound.

2.5.2 Steel Framing Maximum 3 5/8 inch-deep (92 mm), minimum No. 20 gage (0.0359 inch (0.91 mm)) steel studs, spaced 16 inches (406 mm) on center, maximum.

2.5.3 Openings Wall openings are framed with minimum 2 by 4 (51 mm x 102 mm) thick (32 mm) aluminum or steel framing.

2.5.4 Exterior Finish One layer of minimum 1/2 inch-thick (12.7 mm) sheathing, complying with ASTM C 79-92, is applied horizontally to the steel framing with No. 8 by 1 1/4 inch-long (32 mm) bugle head screws spaced 8 inches (203 mm) on center at all framing locations.

2.5.5 Stud Cavity When studs are to be pasted in place, the cavity between each stud level must be blocked with thermal insulation. The thermal insulation (ER-233) is fit into each stud cavity at the top. The insulation has a minimum nominal 4-pound per cubic foot (64 kg/m³) density, is 4 inches (95 mm) thick and is approximately 9 inches (229 mm) wide. To fit within a stud cavity, the insulation is cut long enough to achieve a friction fit.

2.5.6 Stucco System Where a weather-resistant barrier is required, the studs system includes application of one layer of Pyro-Kure 60 vapor retarder, manufactured by Fortifiber. Pyro-Kure vapor retarder has a maximum flame spread of 25 and a maximum smoke developed rating of 30, and qualifies as a Type 1, Grade A weather-resistive barrier, in accordance with JRC Standard 14-1. The vapor retarder is installed over the sheathing in accordance with Section 402.1 of the code. Expanded polystyrene insulation board with a minimum 1.5 pound per cubic foot (24 kg/m³) density is installed 1-inch (25 mm) thickness horizontally in running bond to the sheathing. Reinforcement consists of 1-inch (25 mm) by No. 20 gage galvanized steel self fasteners spaced 16 inches (406 mm) on center.

head self-drilling screws spaced 8 inches (203 mm) on center to framing members. The stucco with glass fibers is applied at 3/8-inch (9.5 mm) minimum thickness in accordance with Section 2.3 of this report.

2.5.7 Without Foam Plastic For walls required to be of noncombustible construction, Diamond Wall with glass fibers is applied over gypsum sheathing and steel studs in accordance with Section 2.3.3.2 of this report.

2.6 Shear Wall

A shear wall providing wall bracing required by Section 2326.11 of the code may be constructed using the Diamond Wall System. The individual shear walls must have a height-to-length ratio comply with Section 2511.4 of the code. Wall framing is minimum 2-by-studs spaced 16 or 24 inches (406 or 610 mm) on center. Fome-Co sheathing recognized in Evaluation Report ER-3335 is applied to framing with 3 inch (76 mm) horizontal weather laps and 6 inch (140 mm) vertical laps, and is spot-fastened into place. The 1 1/2-inch (38 mm) hexagonal opening by No. 11 gage woven wire lath is then applied over Fome-Co and fastened to all framing members at 6 inches (152 mm) on center with No. 16 gage corrosion resistant staples having a 1-inch crown. The staple legs must be a minimum of 1 1/4 inches (32 mm) long and long enough to penetrate framing at least 1 inch (25 mm). The lath is overlapped a minimum of 2 inches (51 mm). Lath overlaps should be offset from Fome-Co overlaps. The Diamond Wall Coating is applied in two coats, in accordance with Section 2.3.1. The base coat is a minimum of 1/2 inch (12.7 mm) thick, and is cured in accordance with Section 2.7.3. The finish coat is a minimum of 1/8 inch (3.2 mm) thick and is applied after proper curing of the base coat.

The allowable racking shear for walls is 170 pcf (2451 N/m²).

2.7 Miscellaneous

2.7.1 Inspection Requirements Building department inspectors are required on lath installation prior to application of the coating as noted in Section 108.5.5 of the code.

The Diamond Wall PM System requires special inspections. In accordance with Section 1701 of the code, for field batching and mixing of components. As an alternative, when approved by the building official, continuous field inspection of all batching and mixing operations by an authorized inspector, trained and approved by Omega Products Corporation, may be used. The authorized inspector must be independent of the plastering contractor. A declaration as noted in Figure 4 shall be completed and signed in duplicate for presentation to the building owner and the building official with the plastering contractor's installation card.

2.7.2 Control Joints Control joints must be installed as specified by the architect, designer, builder or exterior coating manufacturer, and in accordance with the details, conventional three coat plastering details must be used.

2.7.3 Curing Moist curing must be provided for 24 hours after coating applications.

2.7.4 Soffits The system may be applied to soffits, provided the coating is applied over metal lath complying with Table 25-B of the code in lieu of wire fabric lath. Metal lath fastening must comply with Table 25-C, except the fastener length must be increased by the thickness of any substrate.

2.7.5 Sills The system may be applied to sills at locations such as windows and other similar areas. Sills with depths of 6 inches (152 mm) or less may have the coating and lath applied to any substrate permitted in this report, provided the coating, lath, weather-resistive barrier and substrate are installed in accordance with the appropriate section of this report. Sills with depths exceeding 6 inches (152 mm) must have substrates of solid wood or plywood. The substrate is fastened in accordance with Table 25-C of the code.

2.8 Identification.

The factory prepared mix is delivered to the jobsite in labeled, 80-pound (36 kg), water resistive bags with labels bearing the following information:

1. Name and address of manufacturer and the evaluation report number (ICBO ES ER 4004)
2. Identification of components
3. Weight of packaged mix
4. Storage instructions
5. Maximum amount of water and other components that may be added and conditions that must be considered in determining actual amounts added
6. Curing instructions

Polystyrene foam plastic insulation boards are identified in accordance with their respective ICBO ES or NER evaluation reports. Additionally, the board density must be noted. When applied to walls required to be noncombustible construction, each board along one edge, and one board in each package on both faces, must be identified with the foam plastic evaluation report number, the name "Omega Diamond Wall" and the evaluation report number (ER 4004)

3.0 EVIDENCE SUBMITTED

Data in accordance with the ICBO ES Acceptance Criteria for Cementitious Exterior Wall Coatings¹, dated April 1994, data in accordance with UBC Standard 26.4 and reports of racking shear tests.

4.0 FINDINGS

That the Omega Diamond Wall, Thoro One Coat, and Senergy One Coat Insulating Exterior Stucco Systems described in this report comply with the 1994 Uniform Building Code², subject to the following conditions:

- 4.1 The materials and methods of installation comply with this report and the manufacturer's instructions.
- 4.2 Installation is by contractors approved by the manufacturer.

4.3 The system may be installed on walls required to be of non-combustible construction in accordance with Section 2.5.

4.4 The system is recognized as a one-hour fire-resistive assembly when it complies with Section 2.4 of this report. The design stress for the system described in Section 2.4.1 is limited to 0.78 F_v/c, and the maximum stress may not exceed 0.78 F_v/c at a maximum *l*/*d* ratio of 33.

Loads applied to the one-hour fire-resistive wall assembly described in Section 2.4.2 may not exceed the following, whichever is least:

- 1,100 pounds per stud (4893 N)
- Design stress of 0.78 F_v/c in accordance with Section 2307.3 of the code.
- Design stress of 0.78 F_v/c at a maximum *l*/*d* ratio of 33, in accordance with Section 2307.3 of the code.

4.5 The interior of the building is separated from the foam plastic insulation board with a thermal barrier complying with Section 2602 of the code, such as 1/2-inch (12.7 mm) regular gypsum wallboard applied in accordance with Table 25-G of the code.

4.6 An installation card, as shown in Figure 3, is left at the jobsite for the owner and a copy filed with the building department.

4.7 For the Diamond Wall PM System, inspections are required in accordance with Section 2.7.1 of this report. A declaration as shown in Figure 4 is left with the owner, and a copy is filed with the building official.

4.8 The allowable wind load on the system with wood or steel studs 24 inches (610 mm) on center, maximum, is 35 psf (1676 Pa) positive or negative. Supporting framing must be adequate to resist the required wind loads.

1996 Accumulative Supplement: This report is unaffected by the supplement.

This report is subject to re-examination in two years.

TABLE 1—STAPLE SPACING¹ (inches)

WOOD SPECIES	SPECIFIC GRAVITY	STAPLE GAGE				
		16	15	14	13	12
Douglas fir, slash	0.50	6	6	6	6	6
Douglas fir, south	0.46	5	5	6	6	6
Western hemlock	0.47	5	6	6	6	6
Western hemlock, south	0.43	5	6	6	6	6
Hem fir, south	0.46	5	5	6	6	6
Hem fir	0.43	4	4	5	6	6
Spruce pine, fir	0.42	4	4	5	5	6
Western wood	0.36	3	3	3	4	4

¹For SI units = 25.4 mm

²When plywood sheathing is part of the exterior wall, the spacing of the staples may be:

- ³3/8-inch-thick plywood staple spacing = 5 inches on center
- ⁴1/2-inch-thick plywood staple spacing = 4 inches on center

Total penetration is through plywood and wood framing. Intermediate framing fastener spacing must be same as panel perimeter spacing.

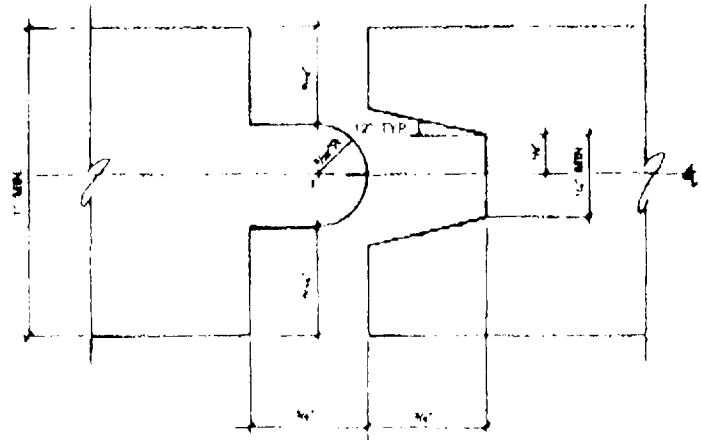
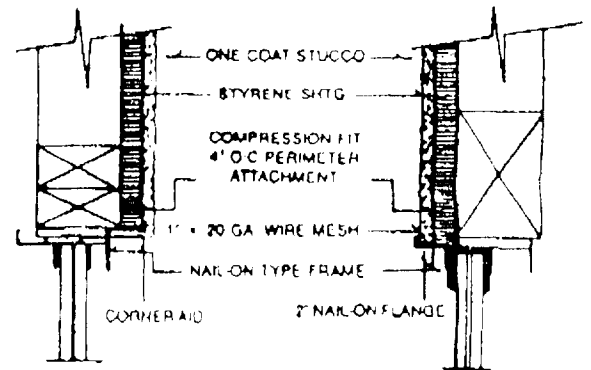
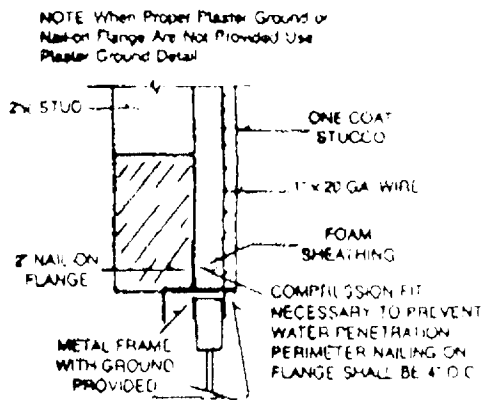
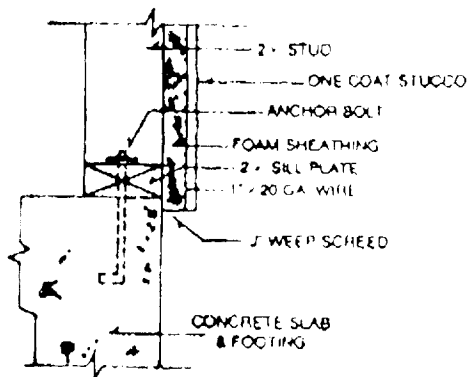

FIGURE 1—TONGUE AND GROOVE



SLIDING DOOR

COMPRESSION FIT-METAL FRAME



SILL FLASHING

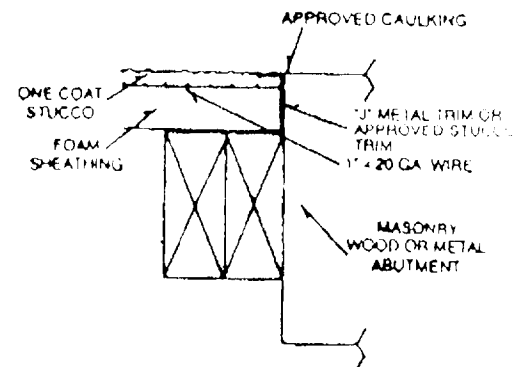

PLASTER GROUND

For Sill Lin. = 25.4 mm

NOTES: 1. WHEN USING SHEATHING OTHER THAN FOAM, THESE DETAILS SHALL APPLY IF OTHER THAN 1\"/>

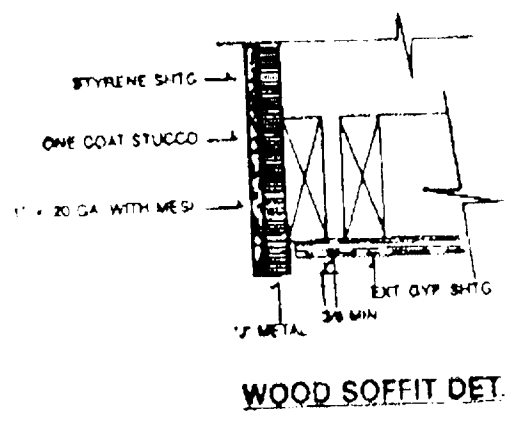

WOOD SOFFIT DET.

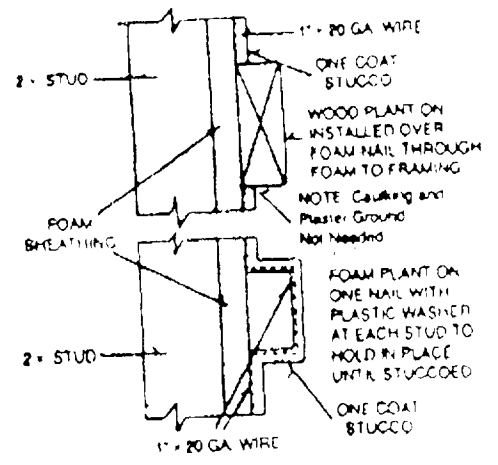

PLANT ON

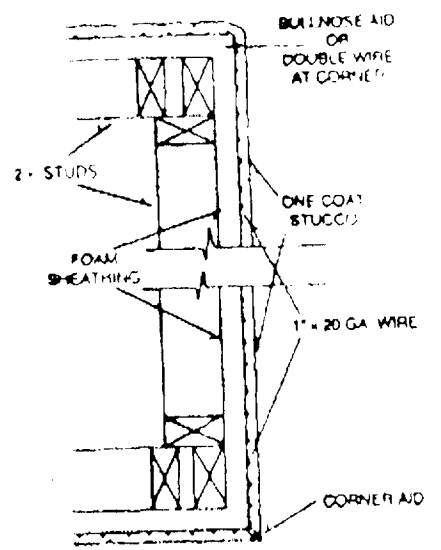

SQUARE CORNER - BULLNOSE CORNER

NOTE: Parapet Cap Should Be Bullnosed or Sloped
Foam Sheathing on Top & Roofside of Parapet
Optional When Foam is Omitted Use Approved Solid Backer

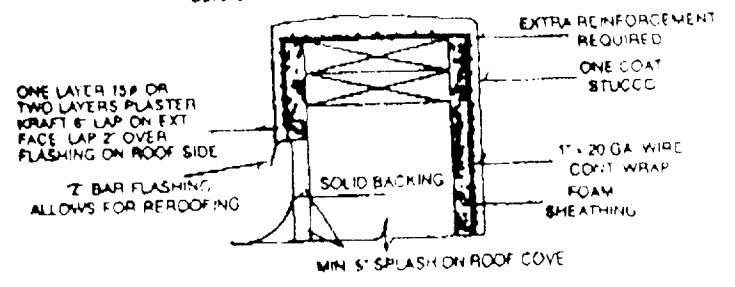

PARAPET & FLASHING DETAIL

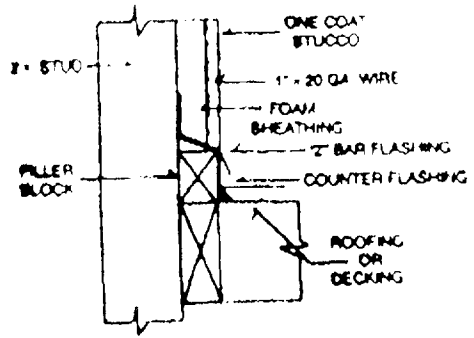

GABLE OR DECK FLASHING

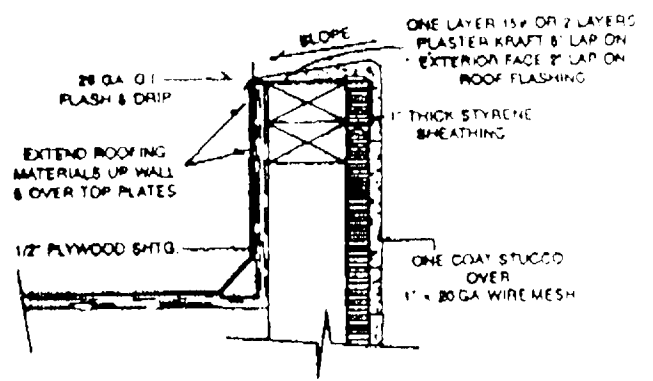

WOOD FRAME DOUBLE FACED PARAPET

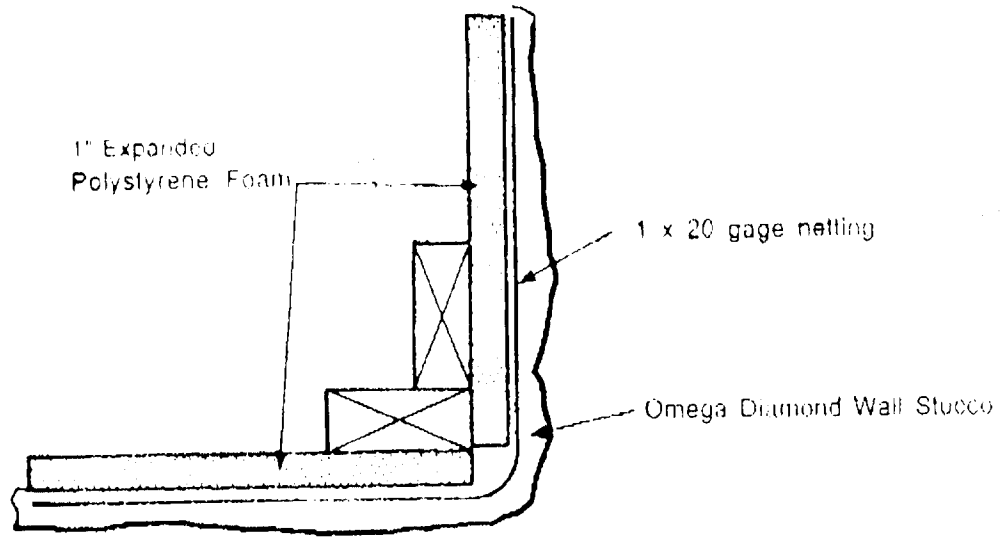

For ST-111-5-25-1 mm

FIGURE 2—DETAILS FOR ONE-COAT STUCCO—(Continued)

INSTALLATION CARD
 (Coating system Trade Name)
 (Name of coating manufacturer)

Job Address

ICBO Evaluation Service, Inc
 Report No. _____

Date of Job Completion _____

Plastering Contractor

Name: _____

Address: _____

Telephone No. () _____

Approved contractor number as issued by the coating manufacturer _____

This is to certify that the exterior coating system on the building exterior at the above address has been installed in accordance with the evaluation report specified above and the manufacturer's instructions

 Signature of authorized representative of plastering contractor

 Date

This installation card must be presented to the building inspector after completion of work and before final inspection

FIGURE 3

Omega Products International, Inc
282 S Anita
Orange CA 92868
(714) 935-0900

DECLARATION

Date:

Project Address:

The batching and mixing of all components of the exterior wall coating at the address noted above have been continuously inspected. The field batching and mixing have been found to comply with current Evaluation Report ER-4004 approved plans.

Authorized inspector's signature

Authorized inspector's name (print)

Employer's name

Employer's address

Telephone Number:

*This certifies that the above noted inspector, approved by Omega Products Corp., was authorized to inspect the project on site, and was trained to properly discharge his duties.

Signature of authorized officer of reporting body

Signature of inspector

Date:

*Signature of authorized inspector must be an employee of evaluation report holder.

California Homes

3031 West March Lane
Stockton, California 95219

Suite 133-South
Corp. Office (209) 951-5444

ARLINGTON PARK; CREEKSIDE

SACRAMENTO, CALIFORNIA

PHASE #4

LOT #4

APN 117-124-004

SCALE: 1"-20'

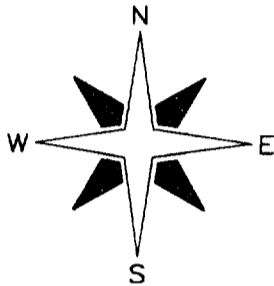

CALVINE ROAD

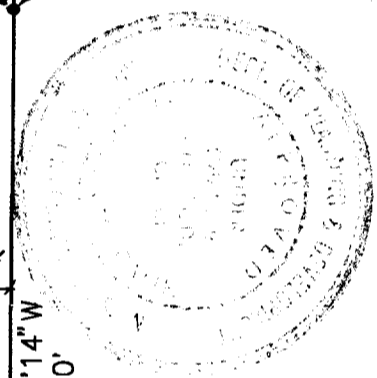
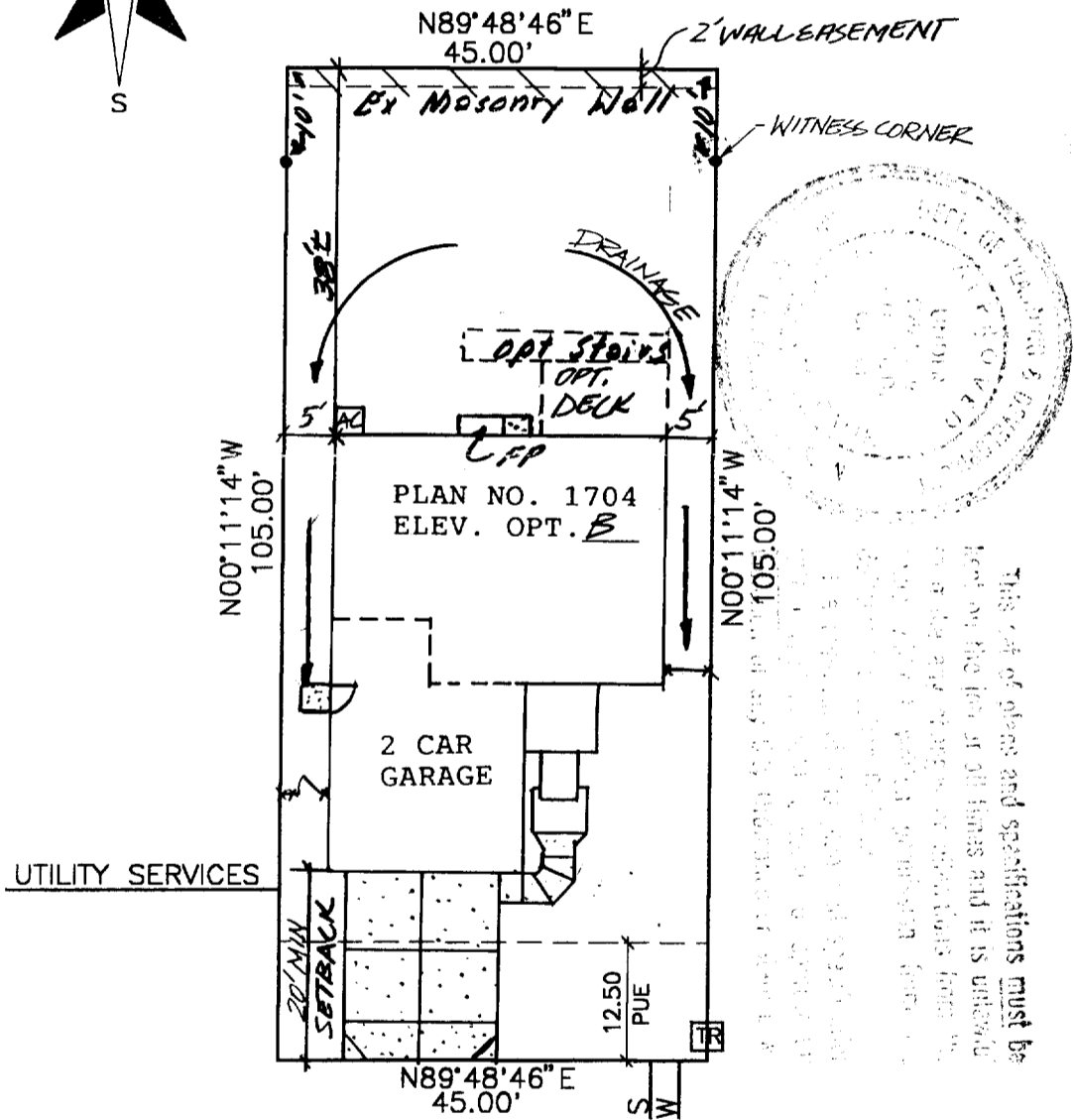

This set of plans and specifications must be read in full at all times and it is understood that any change or alteration from the original design shall be made in writing and signed by the architect and the engineer. The engineer is not responsible for any changes made to the plans or specifications after the date of the original design.

5330 REXLEIGH DR.

MEASUREMENTS ARE APPROXIMATE. CALIFORNIA HOMES RESERVES THE RIGHT TO ALTER WITHOUT PRIOR WRITTEN NOTICE OR OBLIGATIONS.

FINISHED FLOOR SHALL BE 18" MINIMUM ABOVE TOP OF CURB

ALTERATIONS TO GRADING

THE GRADING AND DRAINAGE IS REQUIRED TO CONFORM WITH THE UNIFORM BUILDING CODE AND LOCAL AGENCY REQUIREMENTS. AT FINAL INSPECTION, THE LOCAL AGENCY INSPECTS THE GRADING AND DRAINAGE FOR COMPLIANCE WITH LOCAL DRAINAGE REQUIREMENTS. CALIFORNIA HOMES IS NOT RESPONSIBLE FOR CHANGES MADE TO THE GRADING OR DRAINAGE SWALES.

SHOULD YOU WISH TO CHANGE THE DRAINAGE PATTERN DUE TO LANDSCAPING OR OTHER REASONS, BE SURE THAT A PROPER DRAINAGE METHOD IS RETAINED.

WITHSIGNING BELOW, I INDICATE THAT I UNDERSTAND THE IMPORTANCE OF MAINTAINING A PROPER GRADING AND DRAINAGE SYSTEM.

HOMEOWNER _____

DATE _____

RVD
4/24/98

COUNTY SANITATION DISTRICT NO. 1 SACRAMENTO REGIONAL COUNTY SANITATION DISTRICT

SEWER IMPACT FEE

PERMIT AND CALCULATION SHEET

APPLICATION NO:	BLDG PERMIT NO: <u>City</u>
GENERAL INFORMATION	<p style="text-align: center;">THIS PERMIT GOOD ONLY WHEN VALIDATED BY THE CASHIER <u>2/21/98</u></p> <p> <input type="checkbox"/> CITY OF SACRAMENTO <input type="checkbox"/> TRAFFIC 687002 04/17/98 <input type="checkbox"/> REGIONAL SANIT DISTRICT 687001 04/17/98 </p> <p style="text-align: center;">THIS PERMIT TO CONNECT EXPIRES ONE YEAR FROM DATE OF ISSUANCE</p>

FEE CALCULATION		BUILDING USE	
INSPECTION		RESIDENTIAL SF <input checked="" type="checkbox"/>	MF <input type="checkbox"/>
CSD-1	<u>265</u>	COMMERCIAL USE	UNITS
SRCSD	<u>2336</u>		
CONSTRUCTION			
IN-LIEU			
TOTAL FEE <u>2,601</u>			

APN: 117-1249064

DESCRIPTION/SUBDIVISION Alameda Park Subdivision LOT: 1

PROPERTY ADDRESS 5330 Rexleigh

OWNER John & Jane Smith

MAILING ADDRESS 5330 Rexleigh

CITY-STATE-ZIP Sacramento CA 95817 PHONE (916) 554-1111

ADDITIONAL FEES MAY BE DUE IF CHANGES IN USE INCREASE SEWER IMPACT.

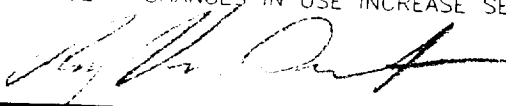
APPLICANT SIGNATURE 

CONSOLIDATED UTILITY BILLING USE ONLY

ACCT _____ INPUT _____ START _____

Certification of Compliance

School District Development Fees

(Print or Type) If Printing, press hard for four copies

PART I To be completed by the APPLICANT

OWNER'S NAME REI Development - AIA California Homes
 OWNER'S ADDRESS 3071 W. March Ave Suite # 100 San Francisco CA 94112
 PROJECT ADDRESS 5330 Rexleigh Dr.
 PARCEL NUMBER 117-129-004 LOT NO. 4
 SUBDIVISION NAME Ardenwood Park Condominium Unit 4
 NUMBER OF UNITS One

Upon payment of the fees listed below, a 90-day approval period commences upon which the applicant paying the fees may protest such fees. Any failure to file such protest within the 90-day period shall result in forfeiture of any rights to challenge such fees, through litigation or otherwise.

APPLICANT'S SIGNATURE [Signature]
 TITLE OF APPLICANT _____
 DATE 6/15/98 PHONE NUMBER 3099/921-5000

PART II To be completed by BUILDING DEPARTMENT

PLAN IDENTIFICATION NUMBER 1704
 BUILDING TYPE
 RESIDENTIAL (X) APARTMENT/CONDOMINIUM () COMMERCIAL/INDUSTRIAL ()
 SQUARE FEET OF CHARGEABLE BUILDING AREA _____
 SIGNATURE _____
 TITLE _____ DATE _____

PART III To be completed by SCHOOL DISTRICT

SCHOOL DISTRICT 52015
 DISTRICT CERTIFICATION NO. 1172
 EXEMPT _____ COMMENTS _____

RESIDENTIAL/APT/CONDO	<u>1704</u>	SQ FT X \$	<u>1.93</u>	= \$	<u>3288.72</u>
COMMERCIAL/INDUSTRIAL		SQ FT X \$		= \$	
OTHER FEE TYPE	<u>1704</u>	SQ FT X \$	<u>1.34</u>	= \$	<u>2283.36</u>
TOTAL FEES COLLECTED	<u>1704</u>	<u>3.27</u>		= \$	<u>5572.08</u>

This Certification covers only the amount of square footage indicated above. Any additions or corrections to the square footage for this project will require an amendment to the Certificate of Compliance.

As the authorized school district official, I hereby certify that the requirements of Government Code Section 65995 and any other authorized requirements have been complied with by the above signed applicant.

AUTHORIZED SCHOOL DISTRICT OFFICIAL

SIGNATURE [Signature] DATE 6-15-98
 TITLE _____