

CITY OF SACRAMENTO
1231 I Street, Sacramento, CA 95814

Permit No: 0010540
Insp Area: 2

Site Address: 10 BEAUCANON CT SAC
Parcel No: 117-1360-056 JACINTO VILLAGE LOT 56

Sub-Type: NSFR
Housing (Y/N): N

CONTRACTOR
BEAZER HOMES
3009 DOUGLAS BL #150
ROSEVILLE CA 95661

OWNER

ARCHITECT

Nature of Work: NSFR MP1232 5 RMS

CONSTRUCTION LENDING AGENCY : I hereby affirm under penalty of perjury that there is a construction lending agency for the performance of the work for which this permit is issued (Sec. 3097, Civ. C).

Lender's Name _____ Lender's Address _____

LICENSED CONTRACTORS DECLARATION: I hereby affirm under penalty of perjury that I am licensed under provisions of Chapter 9 (commencing with section 7000) of Division 3 of the Business and Professions Code and my license is in full force and effect.

License Class B License Number 724191 Date 9/18/00 Contractor Signature Sheyff Van Maeren

OWNER-BUILDER DECLARATION: I hereby affirm under penalty of perjury that I am exempt from the contractors License Law for the following reason (Sec. 7031.5, Business and Professions Code; any city or county which requires a permit to construct, alter, improve, demolish, or repair any structure, prior to its issuance, also requires the applicant for such permit to file a signed statement that he or she is licensed pursuant to the provisions of the Contractors License Law (Chapter 9 (commencing with Section 7000) of Division 8 of the Business and Professions Code) or that he or she is exempt therefrom and the basis for the alleged exemption. Any violation of Section 7031.5 by any applicant for a permit subjects the applicant to a civil penalty of not more than five hundred dollars (\$500.00).

_____, I, as a owner of the property, or my employees with wages as their sole compensation, will do the work, and the structure is not intended or offered for sale (Sec. 7044, Business and Professional Code: The Contractors License Law does not apply to an owner of property who builds or improves thereon, and who does such work himself or herself or through his/her own employees, provided that such improvements are not intended or offered for sale. If, however, the building or improvement is sold within one year of completion, the owner-builder will have the burden of proving that he/she did not build or improve for the purpose of sale.)

_____, I, as owner of the property, am exclusively contracting with licensed contractors to construct the project (Sec. 7044, Business and Professions Code: The Contractors License Law does not apply to an owner of property who builds or improves thereon, and who contracts for such projects with a contractor(s) licensed pursuant to the Contractors License Law).

_____, I am exempt under Sec. _____ B & PC for this reason: _____

Date _____ Owner Signature _____

IN ISSUING THIS BUILDING PERMIT, the applicant represents, and the city relies on the representation of the applicant, that the applicant verified all measurements and locations shown on the application or accompanying drawings and that the improvement to be constructed does not violate any law or private agreement relating to permissible or prohibited locations for such improvements. This building permit does not authorize any illegal location of any improvement or the violation of any private agreement relating to location of improvements.

I certify that I have read this application and state that all information is correct. I agree to comply with all city and county ordinances and state laws relating to building construction and hereby authorize representative(s) of this city to enter upon the abovementioned property for inspection purposes.

Date 9/18/00 Applicant/Agent Signature Sheyff Van Maeren

WORKER'S COMPENSATION DECLARATION: I hereby affirm under penalty of perjury one of the following declarations:

_____, I have and will maintain a certificate of consent to self-insure for workers' compensation as provided for by Section 3700 of the Labor Code, for the performance of work for which the permit is issued.

I have and will maintain workers' compensation insurance, as required by Section 3700 of the Labor Code, for the performance of the work for which this permit is issued. My workers' compensation insurance carrier and policy number are:

Carrier LIBERTY MUTUAL INS CO. Policy Number WA2-651-004147-080 Exp Date 4/1/2001

_____, (This section need not be completed if the permit is for \$100 or less) I certify that in the performance of the work for which this permit is issued, I shall not employ any person in any manner so as to become subject to the workers' compensation laws of California and agree that if I should become subject to the workers' compensation provisions of Section 3700 of the Labor Code, I shall forthwith comply with those provisions.

Date 9/18/00 Applicant Signature Sheyff Van Maeren

WARNING: FAILURE TO SECURE WORKER'S COMPENSATION COVERAGE IS UNLAWFUL AND SHALL SUBJECT AN EMPLOYER TO CRIMINAL PENALTIES AND CIVIL FINES UP TO ONE HUNDRED THOUSAND DOLLARS (\$100,000) IN ADDITION TO THE COST OF COMPENSATION, DAMAGES AS PROVIDED FOR IN SECTION 3706 OF THE LABOR CODE, INTEREST AND ATTORNEY'S FEE.

THIS PERMIT SHALL EXPIRE BY LIMITATION IF WORK IS NOT COMMENCED WITHIN 180 DAYS.

RESIDENTIAL BUILDING PERMIT APPLICATION

New Construction Addition Remodels Other

Project Address: 10 Beaucamon Assessor Parcel # 117-136-056
Lot 56

OWNER INFORMATION:

| | |
|--|--|
| Legal Property Owner: <u>Beazer Homes</u> | Phone # <u>773-3888</u> |
| Owner Address: <u>3009 Douglas Blvd. 150</u> | City <u>Roseville</u> State <u>CA</u> Zip <u>95661</u> |

CONTRACTOR INFORMATION:

| | | | |
|---------------------------------|-----------------------|-------------------------|----------------------|
| Contractor: <u>Beazer Homes</u> | Lic. # <u>B724191</u> | Phone # <u>773-3888</u> | Fax# <u>773-0425</u> |
|---------------------------------|-----------------------|-------------------------|----------------------|

PROJECT INFORMATION:

| | | | |
|--|-------------------------------------|-------------------------|---------------------|
| Land Use Zone _____ | Occupancy Group _____ | Construction Type _____ | Fed Code _____ |
| No. of stories: <u>1</u> | No. of rooms: _____ | Street width: _____ | |
| 1 st Floor Area <u>1232</u> | 2 nd Floor Area <u>0</u> | Basement <u>0</u> | Roof Material _____ |

| | | |
|--------------------------------|-----------------------|-------------|
| AREA IN SQUARE FOOT OF: | EXISTING | NEW |
| | Dwelling/Living _____ | <u>1232</u> |
| | Garage/Storage _____ | <u>426</u> |
| | Decks/Balconies _____ | <u>0</u> |
| | Carports _____ | <u>0</u> |

SCOPE OF WORK: NEW SFD

FOR OFFICE USE ONLY

| | | |
|---|---|--|
| <input type="checkbox"/> Information above complete | <input type="checkbox"/> AR Flood Waiver required | <input type="checkbox"/> Planning Approval |
| <input type="checkbox"/> Violation files checked | <input type="checkbox"/> Flood Elevation Certificate Required | <input type="checkbox"/> Design Review Approval |
| <input type="checkbox"/> Standard setbacks | <input type="checkbox"/> Water Development Infill Area | <input type="checkbox"/> Special Fee Districts Apply : _____ |
| <input type="checkbox"/> County Sewer | | |

NEW STRUCTURES & ADDITIONS

*THE FOLLOWING MUST BE PROVIDED IN ORDER TO SUBMIT FOR PLAN REVIEW

| | |
|---|---|
| <input type="checkbox"/> 2 COMPLETE PLANS, LEGIBLE & DRAWN TO SCALE | * Plans to include: site plan, floor plan, elevations, roof/ceiling plan, foundation and structural framing details, and structural calculations for non-conforming structures. |
| <input type="checkbox"/> 3 SETS IF PROJECT IS IN A DESIGN REVIEW AREA | |
| <input type="checkbox"/> Title 24 Energy Compliance documentation | <input type="checkbox"/> 11" x 17" copy of floor plan for County Assessor |
| <input type="checkbox"/> Grading and Erosion Control Questionnaire | <input type="checkbox"/> Plan Review Fees |

Date: _____ Received by: (staff) _____

| |
|--------------------------|
| ACTIVITY/PERMIT # |
|--------------------------|

KWIKKOTE
STUCCO SYSTEM
INSTALLATION CARD

20985
Beazer Homes
Beliefleur Lot 56
10 Beaucanon Court Sacramento

Stucco System Trade Name: KWIK KOTE
Name Stucco Manufacturer: KWIK KOTE CORP
ICBO Evaluation Service, Inc. Report No. 3607
Date of Job Completion _____

Stucco Contractor Kenyon Plastering, Inc.
Name John W. Kenyon, III
Address P.O. Box 2077
North Highlands, CA 95660
Telephone # (916) 349-8191

Approved Contractor Number as issued by the Stucco Manufacturer: 1

This is to certify that the stucco system on the building exterior at the above address had been installed in accordance with the evaluation report specified above and the manufacturer's instructions.

Signature of authorized representative of Installer: _____

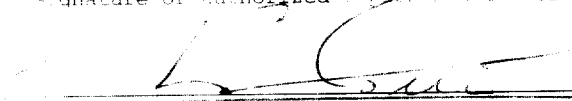

Date: 2-25-01

Builder Copy

CERTIFICATION OF INSULATION

PART I GENERAL
PART II AREAS INSULATED

| | |
|--|---|
| ADDRESS OR TRACT BEZER BELLE FLEUR | SACRAMENTO INSULATION CONTRACTORS <input checked="" type="checkbox"/> P.O. BOX 854, WEST SACRAMENTO, CA 95691 LIC. #202026 <input type="checkbox"/> 1309 MELODY ROAD, MARYSVILLE, CA 95901 LIC. #202026 <input type="checkbox"/> P.O. BOX 9651, FRESNO, CA 93793-9651 LIC. #202026 <input type="checkbox"/> P.O. BOX 1631, RENO, NV 89505 LIC. #10675 <input type="checkbox"/> 3326 A PONDEROSA WAY, LAS VEGAS, NV 89118 LIC. #10675 DATE INSULATION COMPLETED 2/12/01 |
|--|---|

| WALLS | | CEILINGS | | | FLOORS | |
|-----------------------------|-------------------|-----------------------------|-------------------|---------------------------------------|-----------------------------|-------------------|
| SQUARE FEET) | | SQUARE FEET) | | | (SQUARE FEET) | |
| TYPE OF INSULATION | | TYPE OF INSULATION | | | TYPE OF INSULATION | |
| MATERIAL: FIBERGLASS | | MATERIAL: FIBERGLASS | | | MATERIAL: FIBERGLASS | |
| FORM: BATTS | | FORM: BATTS & BLOW | | | FORM: BATTS | |
| MANUFACTURER'S PRODUCT I.D. | | MANUFACTURER'S PRODUCT I.D. | | | MANUFACTURER'S PRODUCT I.D. | |
| MANUFACTURER | | MANUFACTURER | | | MANUFACTURER | |
| OCF | | OCF | | | OCF | |
| R-VALUE INSTALLED | APPLIED THICKNESS | R-VALUE INSTALLED | APPLIED THICKNESS | MIN. INSTALLED WEIGHT PER SQUARE FOOT | R-VALUE INSTALLED | APPLIED THICKNESS |
| 13 | 3 5/8 | 38 | 12 1/4 | | | |
| | | 38 | 14 3/4 | | | |

KNEE WALLS IF R-VALUE IS OTHER THAN WALLS ABOVE

| | | | |
|----------------------|-------------|---------|-------------------|
| MATERIAL: FIBERGLASS | FORM: BATTS | R-VALUE | MANUFACTURER: OCF |
|----------------------|-------------|---------|-------------------|

AIR INFILTRATION SEALANT

| | |
|----------------|-------------------------|
| MATERIAL: FLAM | MANUFACTURER: W R GRACE |
|----------------|-------------------------|

THIS IS TO CERTIFY THAT INSULATION AND/OR SEALANT HAS BEEN INSTALLED IN CONFORMANCE WITH APPLICABLE CODES, MATERIAL STANDARDS AND REGULATIONS.

| | | |
|---|------------------|-----------------|
| SIGNATURE - INSULATION CONTRACTOR <i>Bill Gray</i> | TITLE MANAGER | DATE 1-24-01 |
| SIGNATURE - GENERAL CONTRACTOR | TITLE | DATE |

REMARKS

| ROUTING/APPROVAL | | INITIALS |
|------------------|---|----------|
| President | ✓ | |
| | | |
| | | |

THIS PLOT PLAN IS NOT FOR SALES PURPOSES. THIS PLOT PLAN IS FOR THE PURPOSES OF INDICATING COMPLIANCE WITH ZONING SET BACKS, GENERAL DRAINAGE DIRECTION, AND APPROXIMATE UTILITY CONNECTION. ALL OTHER DATA SHOWN HEREON IS CONCEPTUAL. THIS PLOT PLAN DOES NOT REFLECT AS-BUILT CONDITION. RETAINING WALLS ARE OPTIONAL AND MAY OR MAY NOT BE CONSTRUCTED.

BEAUCANON CT.

- W — WATER METER BOX
- E — ELECTRICAL BOX
- ⊕ — UTILITY RISERS
- — SEWER CLEANOUT
- T — TRANSFORMER

FRONT YARD
VARIABLE
SETBACK
15'-26'(TYP)

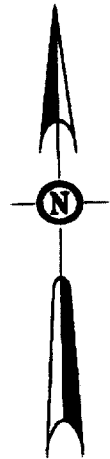

SCALE: 1"=20'

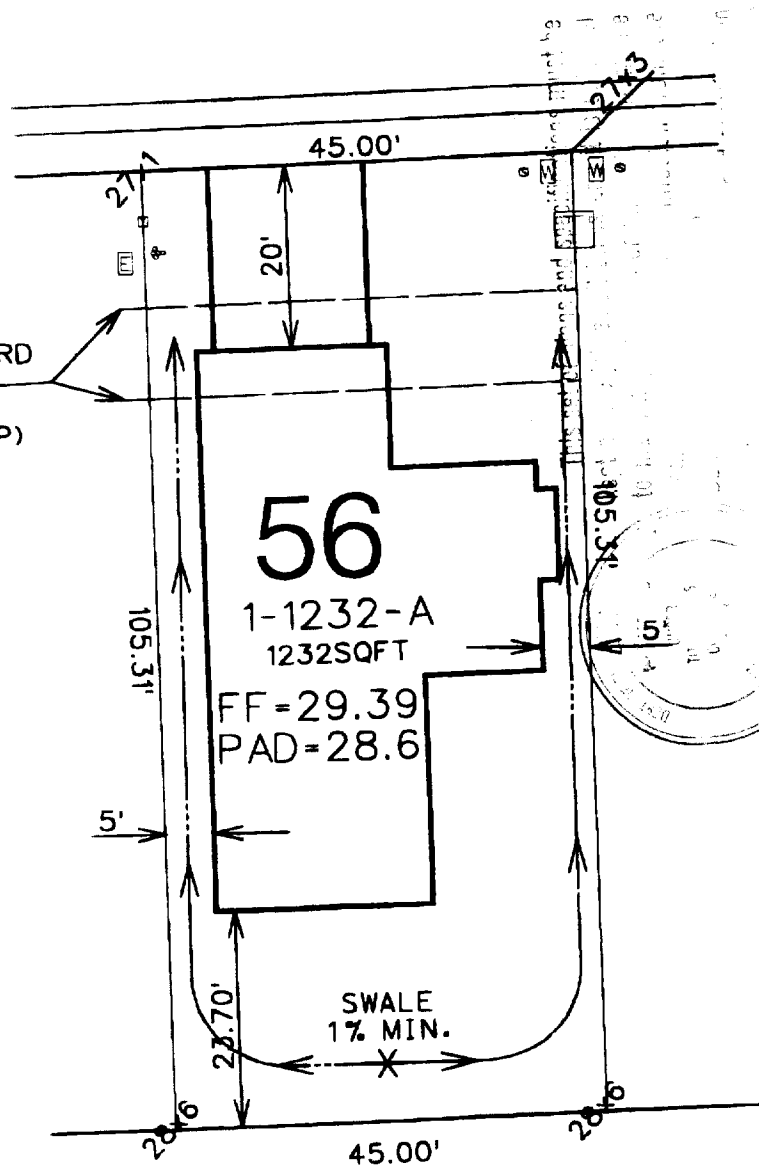

4739 SQUARE FEET

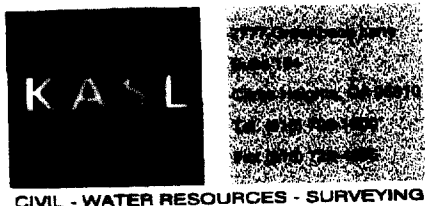

CIVIL - WATER RESOURCES - SURVEYING

PLOT PLAN FOR
LOT 56
JACINTO VILLAGE SOUTH
A.P.N. 117-1360-056
ADDRESS:
COUNTY: SACRAMENTO

SCALE: 1"=20'
DATE: 08-28-00
REVISED:
DRAWN BY: PRA
CHK'D. BY: LK
W.O. 0435-01