

CITY OF SACRAMENTO
1231 I Street, Sacramento, CA 95814

Permit No: 0010868
Insp Area: 4

Site Address: 2049 MOONSTONE WY SAC
Parcel No: 225-1410-038
N

Sub-Type: NSFR
NORTHPOINTE PARK UNIT 7-2 LOT 38
Housing (Y/N):

CONTRACTOR
CENTEX HOMES
3300 DOUGLAS BLVD
STE 210 95661

OWNER

ARCHITECT

Nature of Work: NSFR MP1603 7 RMS 2 STORY

CONSTRUCTION LENDING AGENCY : I hereby affirm under penalty of perjury that there is a construction lending agency for the performance of the work for which this permit is issued (Sec. 3097, Civ. C).

Lender's Name N/A Lender's Address _____

LICENSED CONTRACTORS DECLARATION: I hereby affirm under penalty of perjury that I am licensed under provisions of Chapter 9 (commencing with section 7000) of Division 3 of the Business and Professions Code and my license is in full force and effect.

License Class B License Number 724094 Date 9/25/00 Contractor Signature Debbie Stowers

OWNER-BUILDER DECLARATION: I hereby affirm under penalty of perjury that I am exempt from the contractors License Law for the following reason (Sec. 7031.5, Business and Professions Code; any city or county which requires a permit to construct, alter, improve, demolish, or repair any structure, prior to its issuance, also requires the applicant for such permit to file a signed statement that he or she is licensed pursuant to the provisions of the Contractors License Law (Chapter 9 (commencing with Section 7000) of Division 8 of the Business and Professions Code) or that he or she is exempt therefrom and the basis for the alleged exemption. Any violation of Section 7031.5 by any applicant for a permit subjects the applicant to a civil penalty of not more than five hundred dollars (\$500.00):

I, as a owner of the property, or my employees with wages as their sole compensation, will do the work, and the structure is not intended or offered for sale (Sec. 7044, Business and Professional Code: The Contractors License Law does not apply to an owner of property who builds or improves thereon, and who does such work himself or herself or through his/her own employees, provided that such improvements are not intended or offered for sale. If, however, the building or improvement is sold within one year of completion, the owner-builder will have the burden of proving that he/she did not build or improve for the purpose of sale.)

I, as owner of the property, am exclusively contracting with licensed contractors to construct the project (Sec. 7044, Business and Professions Code: The Contractors License Law does not apply to an owner of property who builds or improves thereon, and who contracts for such projects with a contractor(s) licensed pursuant to the Contractors License Law).

I am exempt under Sec. _____ B & PC for this reason: _____

Date _____ Owner Signature _____

IN ISSUING THIS BUILDING PERMIT, the applicant represents, and the city relies on the representation of the applicant, that the applicant verified all measurements and locations shown on the application or accompanying drawings and that the improvement to be constructed does not violate any law or private agreement relating to permissible or prohibited locations for such improvements. This building permit does not authorize any illegal location of any improvement or the violation of any private agreement relating to location of improvements.

I certify that I have read this application and state that all information is correct. I agree to comply with all city and county ordinances and state laws relating to building construction and herby authorize representative(s) of this city to enter upon the abovementioned property for inspection purposes.

Date 9-25-00 Applicant/Agent Signature Debbie Stowers

WORKER'S COMPENSATION DECLARATION: I hereby affirm under penalty of perjury one of the following declarations:

I have and will maintain a certificate of consent to self-insure for workers' compensation as provided for by Section 3700 of the Labor Code, for the performance of work for which the permit is issued.

I have and will maintain workers' compensation insurance, as required by Section 3700 of the Labor Code, for the performance of the work for which this permit is issued. My workers' compensation insurance carrier and policy number are:

Carrier AMER. GUAR. & LIAB. INS. Policy Number WC8322096-02 Exp Date 10/01/2000

(This section need not be completed if the permit is for \$100 or less) I certify that in the performance of the work for which this permit is issued, I shall not employ any person in any manner so as to become subject to the workers' compensation laws of California and agree that if I should become subject to the workers' compensation provisions of Section 3700 of the Labor Code, I shall forthwith comply with those provisions.

Date 9-25-00 Applicant Signature Debbie Stowers

WARNING: FAILURE TO SECURE WORKER'S COMPENSATION COVERAGE IS UNLAWFUL AND SHALL SUBJECT AN EMPLOYER TO CRIMINAL PENALTIES AND CIVIL FINES UP TO ONE HUNDRED THOUSAND DOLLARS (\$100,000) IN ADDITION TO THE COST OF COMPENSATION, DAMAGES AS PROVIDED FOR IN SECTION 3706 OF THE LABOR CODE, INTEREST AND ATTORNEY'S FEE.

THIS PERMIT SHALL EXPIRE BY LIMITATION IF WORK IS NOT COMMENCED WITHIN 180 DAYS.

New Construction

Addition

Remodels

Other

0010868

Project Address: 2049 Moonstone Avenue

Assessor Parcel # 225-1410-038

Lot 33

OWNER INFORMATION:

Legal Property Owner: Centex Homes Phone # 736-8693
 Owner Address: 3700 Douglas Blvd # 150 City Roseville State CA Zip 95661

CONTRACTOR INFORMATION:

Contractor: Centex Homes Lic. # 734094 Phone # 736-8693 Fax# 736-6802

PROJECT INFORMATION:

Land Use Zone RIA Occupancy Group R3 Construction Type VN Fed Code 1A
 No. of stories: 2 No. of rooms: _____ Street width: _____
 1st Floor Area 871 2nd Floor Area 732 Basement _____ Roof Material _____

AREA IN SQUARE FOOT OF:	EXISTING	NEW
Dwelling/Living	_____	<u>1603</u>
Garage/Storage	_____	<u>437</u>
Decks/Balconies	_____	_____
Carports	_____	_____

SCOPE OF WORK: MP 1203 New Home Construction

FOR OFFICE USE ONLY

- Information above complete
- Violation files checked
- Standard setbacks
- County Sewer
- AR Flood Waiver required
- Flood Elevation Certificate Required
- Water Development Infill Area
- Planning Approval
- Design Review Approval
- Special Fee Districts Apply : _____

NEW STRUCTURES & ADDITIONS

❖ THE FOLLOWING MUST BE PROVIDED IN ORDER TO SUBMIT FOR PLAN REVIEW

- 2 COMPLETE PLANS, LEGIBLE & DRAWN TO SCALE
- 3 SETS IF PROJECT IS IN A DESIGN REVIEW AREA
- Title 24 Energy Compliance documentation
- Grading and Erosion Control Questionnaire
- Plans to include: site plan, floor plan, elevations, roof/ceiling plan, foundation and structural framing details, and structural calculations for non-conforming structures.
- 11" x 17" copy of floor plan for County Assessor
- Plan Review Fees

Date: _____

Received by: (staff) _____

ACTIVITY/PERMIT # _____

Note to Buyer: This plot plan is provided as a general layout of the property. All information on this plan, including but not limited to tree locations and sizes, setback dimensions, driveway grades, and wall heights and locations, are approximate and may vary or change without prior notice.

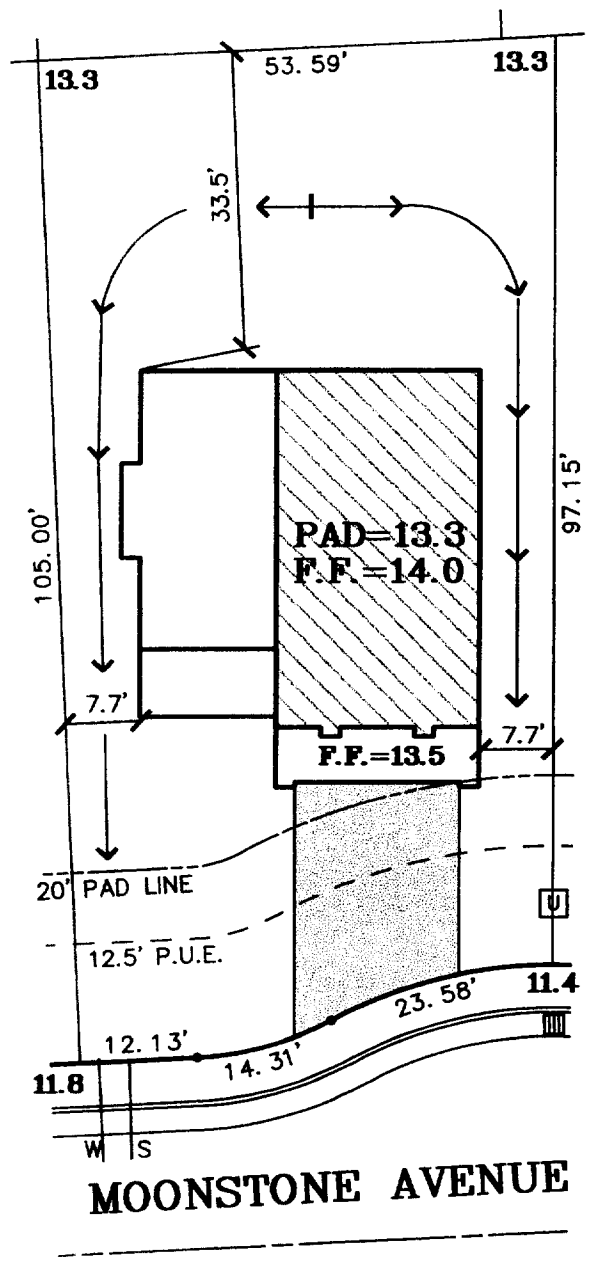

This set of plans and specifications must be kept on the job at all times and it is unlawful to make any changes or alterations from the same without written permission from the Building Inspection Division.
 The approval of this plan and specification SHALL NOT be held to permit or authorize any violation of any City Ordinance or State Law.

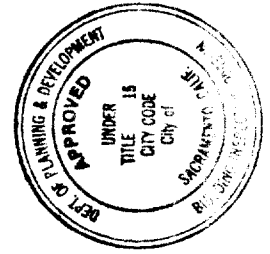

LOT 38
PLAN 1603A RIGHT
A.P.N.:
ADDRESS: 2049 MOONSTONE AVENUE
LOT AREA: 5,211 SF
LOT COVERAGE: 27%

READ AND APPROVED
 Plan 1603 Land Development SA 9/5
 Elevation A Const. Manager _____
 Orientation G-RIGHT Sales Appr. _____
 Color 2 Field Manager _____

The Spink Corporation
 2590 VENTURE OAKS WAY
 SACRAMENTO, CA. 95833

CENTEX HOMES
 3700 Douglas Boulevard
 Suite 150
 Roseville, Ca. 95661

NORTHPOINTE PARK
UNIT NO. 7 PHASE 2
 City of Sacramento, California

office: (916) 786-8693
 fax: (916) 786-6802

Scale: 1"=20'

August 17, 2000