

**CITY OF SACRAMENTO**  
1231 I Street, Sacramento, CA 95814

**Permit No: 0009707**  
**Insp Area: 4**

**Site Address: 9 RIVERSCAPE CT SAC**  
Parcel No: 274-0550-021 SHOREBIRD UNIT 1 LOT 21

Sub-Type: NSFR  
Housing (Y/N): N

CONTRACTOR  
CITATION NORTHERN  
597 CENTER AVE STE. 150  
MARTINEZ CA. 94553

OWNER

ARCHITECT

**Nature of Work: MP2161 2 STORY 9 ROOM SFR**

**CONSTRUCTION LENDING AGENCY :** I hereby affirm under penalty of perjury that there is a construction lending agency for the performance of the work for which this permit is issued (Sec. 3097, Civ. C).

Lender's Name \_\_\_\_\_ Lender's Address \_\_\_\_\_

**LICENSED CONTRACTORS DECLARATION:** I hereby affirm under penalty of perjury that I am licensed under provisions of Chapter 9 (commencing with section 7000) of Division 3 of the Business and Professions Code and my license is in full force and effect.

License Class B License Number 547764 Date 8-24-00 Contractor Signature 

**OWNER-BUILDER DECLARATION:** I hereby affirm under penalty of perjury that I am exempt from the contractors License Law for the following reason (Sec. 7031.5, Business and Professions Code; any city or county which requires a permit to construct, alter, improve, demolish or repair any structure, prior to its issuance, also requires the applicant for such permit to file a signed statement that he or she is licensed pursuant to the provisions of the Contractors License Law (Chapter 9 (commencing with Section 7000) of Division 8 of the Business and Professions Code) or that he or she is exempt therefrom and the basis for the alleged exemption. Any violation of Section 7031.5 by any applicant for a permit subjects the applicant to a civil penalty of not more than five hundred dollars (\$500.00);

\_\_\_\_ I, as a owner of the property, or my employees with wages as their sole compensation, will do the work, and the structure is not intended or offered for sale (Sec. 7044, Business and Professional Code: The Contractors License Law does not apply to an owner of property who builds or improves thereon, and who does such work himself or herself or through his/her own employees, provided that such improvements are not intended or offered for sale. If, however, the building or improvement is sold within one year of completion, the owner-builder will have the burden of proving that he/she did not build or improve for the purpose of sale.)

\_\_\_\_ I, as owner of the property, am exclusively contracting with licensed contractors to construct the project (Sec. 7044, Business and Professions Code: The Contractors License Law does not apply to an owner of property who builds or improves thereon and who contracts for such projects with a contractor(s) licensed pursuant to the Contractors License Law).

\_\_\_\_ I am exempt under Sec. \_\_\_\_\_ B & PC for this reason: \_\_\_\_\_  
Date \_\_\_\_\_ Owner Signature \_\_\_\_\_

**CITY OF SACRAMENTO**  
AUG 24 2000

**IN ISSUING THIS BUILDING PERMIT,** the applicant represents, and the city relies on his representation of the applicant that the applicant verified all measurements and locations shown on the application or accompanying drawings and that the improvement to be constructed does not violate any law or private agreement relating to permissible or prohibited locations for such improvements. This building permit does not authorize any illegal location of any improvement or the violation of any private agreement relating to location of improvements.

**NEIGHBORHOODS PLANNING AND DEVELOPMENT SERVICES**

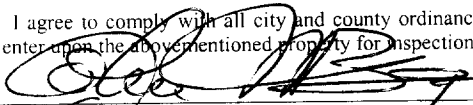
I certify that I have read this application and state that all information is correct. I agree to comply with all city and county ordinances and state laws relating to building construction and hereby authorize representative(s) of this city to enter upon the above mentioned property for inspection purposes.  
Date 8-24-00 Applicant/Agent Signature 

**WORKER'S COMPENSATION DECLARATION:** I hereby affirm under penalty of perjury one of the following declarations:  
\_\_\_\_ I have and will maintain a certificate of consent to self-insure for workers' compensation as provided for by Section 3700 of the Labor Code, for the performance of work for which the permit is issued.

I have and will maintain workers' compensation insurance, as required by Section 3700 of the Labor Code, for the performance of the work for which this permit is issued. My workers' compensation insurance carrier and policy number are:

Carrier \_\_\_\_\_ Policy Number \_\_\_\_\_ Exp Date \_\_\_\_\_

\_\_\_\_ (This section need not be completed if the permit is for \$100 or less) I certify that in the performance of the work for which this permit is issued, I shall not employ any person in any manner so as to become subject to the workers' compensation laws of California and agree that if I should become subject to the workers' compensation provisions of Section 3700 of the Labor Code, I shall forthwith comply with those provisions.

Date 8-24-00 Applicant Signature 

**WARNING: FAILURE TO SECURE WORKER'S COMPENSATION COVERAGE IS UNLAWFUL AND SHALL SUBJECT AN EMPLOYER TO CRIMINAL PENALTIES AND CIVIL FINES UP TO ONE HUNDRED THOUSAND DOLLARS (\$100,000) IN ADDITION TO THE COST OF COMPENSATION, DAMAGES AS PROVIDED FOR IN SECTION 3706 OF THE LABOR CODE, INTEREST AND ATTORNEY'S FEE.**

**THIS PERMIT SHALL EXPIRE BY LIMITATION IF WORK IS NOT COMMENCED WITHIN 180 DAYS.**

0009107  
LOT 21

RESIDENTIAL BUILDING PERMIT APPLICATION

New Construction     Addition     Remodels     Other

Project Address: 9 RIVERSCAPE COURT    Assessor Parcel # 274-0550-021

OWNER INFORMATION:

Legal Property Owner: Citation Northern    Phone # (925) 372-0300  
Owner Address: 597 Center Avenue, #150 City Martinez    State CA    Zip 94553

CONTRACTOR INFORMATION:

Contractor: Citation Northern Lic. # 547764    Phone # (925) 372-0300    Fax # (925) 228-1833

PROJECT INFORMATION:

Land Use Zone _____	Occupancy Group _____	Construction Type _____	Fed Code _____
No. of stories: <u>2</u>	No. of rooms: <u>9</u>	Street width: <u>46'</u> R/W	
1 <sup>st</sup> Floor Area <u>1,281</u>	2 <sup>nd</sup> Floor Area <u>880</u>	Basement _____	Roof Material <u>TILE</u>
AREA IN SQUARE FOOT OF:		<b>EXISTING</b>	<b>NEW</b>
Dwelling/Living		_____	<u>2,161</u>
Garage/Storage		_____	<u>576</u>
Decks/Balconies		_____	_____
Carports		_____	<u>2737</u>
SCOPE OF WORK: <u>Single Family</u>			Plan <u>22</u> Master

FOR OFFICE USE ONLY

- |   |   |  |
|---|---|--|
| <input type="checkbox"/> Information above complete | <input type="checkbox"/> AR Flood Waiver required             | <input type="checkbox"/> Planning Approval                   |
| <input type="checkbox"/> Violation files checked    | <input type="checkbox"/> Flood Elevation Certificate Required | <input type="checkbox"/> Design Review Approval              |
| <input type="checkbox"/> Standard setbacks          | <input type="checkbox"/> Water Development Infill Area        | <input type="checkbox"/> Special Fee Districts Apply : _____ |
| <input type="checkbox"/> County Sewer               |   |  |

NEW STRUCTURES & ADDITIONS

◆ THE FOLLOWING MUST BE PROVIDED IN ORDER TO SUBMIT FOR PLAN REVIEW

- |   |   |
|---|---|
| <input type="checkbox"/> 2 COMPLETE PLANS, LEGIBLE & DRAWN TO SCALE   | ◆ Plans to include: site plan, floor plan, elevations, roof/ceiling plan, foundation and structural framing details, and structural calculations for non-conforming structures. |
| <input type="checkbox"/> 3 SETS IF PROJECT IS IN A DESIGN REVIEW AREA |   |
| <input type="checkbox"/> Title 24 Energy Compliance documentation     | <input type="checkbox"/> 11" x 17" copy of floor plan for County Assessor   |
| <input type="checkbox"/> Grading and Erosion Control Questionnaire    | <input type="checkbox"/> Plan Review Fees   |

Date: \_\_\_\_\_ Received by: (staff) \_\_\_\_\_

ACTIVITY/PERMIT # \_\_\_\_\_

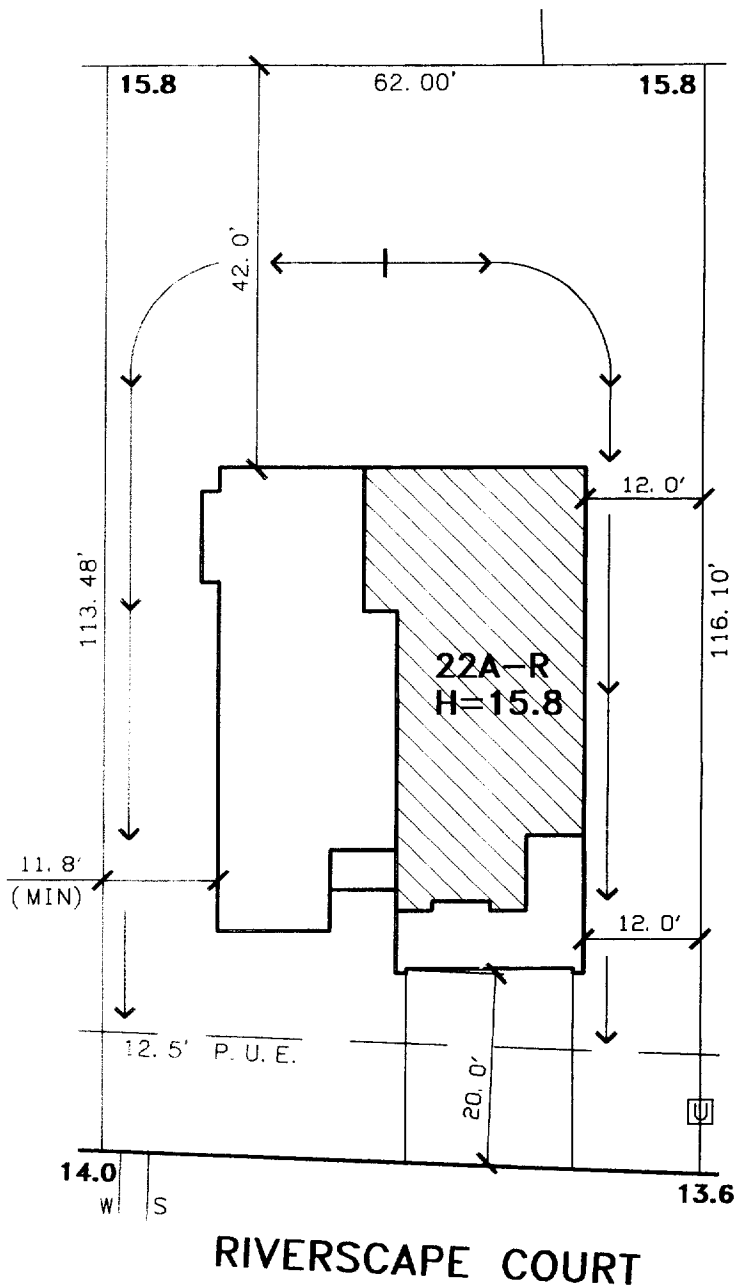

This set of plans and specifications must be kept on the job at all times and it is unlawful to make any changes or alterations to the same without written permission of the City of Sacramento.

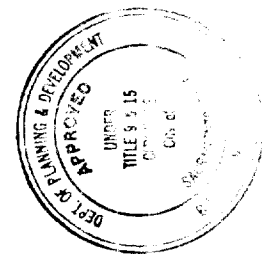

DATE: 8-17-00 REV  
 A.P.N.:  
 ADDRESS: RIVERSCAPE COURT

LOT AREA: 7,117 SF  
 LOT COVERAGE: 27%

<p><b>The Splink Corporation</b>          2590 VENTURE OAKS WAY          SACRAMENTO, CA. 95833          PH (916)925-5550 FAX (916)921-9274</p>	<p><b>SHOREBIRD          UNIT NO. 1</b>          LOT 21          PLAN 22A</p>	<p><b>SHOREBIRD</b>          CITY OF SACRAMENTO, CA          CLIENT: CITATION NORTHERN          JOB NO.: 1579-001</p>
--	---	---



**INSULATION CONTRACTORS  
ASSOCIATION  
OF AMERICA**

INSULATION  
CERTIFICATE

60645

1321 DUKE STREET, SUITE 303 • ALEXANDRIA, VA 22314 • (703) 739-0356

THIS IS TO CERTIFY THAT INSULATION HAS BEEN INSTALLED IN CONFORMANCE WITH CURRENT ENERGY REGULATIONS, CALIFORNIA ADMINISTRATIVE CODE, TITLE 24, STATE OF CALIFORNIA, IN THE BUILDING LOCATED AT:

Location Northridge LOT # 21 TRACT # Franklin  
STREET 9 Riverscape Ct CITY Sacramento

EXTERIOR WALLS:

MANUFACTURER \_\_\_\_\_ THICKNESS/TYPE \_\_\_\_\_ R-VALUE \_\_\_\_\_

CEILINGS:

BATTS:

MANUFACTURER \_\_\_\_\_ THICKNESS/TYPE \_\_\_\_\_ R-VALUE \_\_\_\_\_

BLOWN IN:

MANUFACTURER InsulSafe IV THICKNESS 14 3/4 MINIMUM R-VALUE 38

SQUARE FOOTAGE COVERED 515 NUMBER OF BAGS USED 12

FLOORS:

MANUFACTURER \_\_\_\_\_ THICKNESS/TYPE \_\_\_\_\_ R-VALUE \_\_\_\_\_

SLAB ON GRADE:

MANUFACTURER \_\_\_\_\_ THICKNESS/TYPE \_\_\_\_\_ R-VALUE \_\_\_\_\_

WIDTH OF INSULATION \_\_\_\_\_ INCHES

FOUNDATION WALLS:

MANUFACTURER \_\_\_\_\_ THICKNESS/TYPE \_\_\_\_\_ R-VALUE \_\_\_\_\_

GENERAL CONTRACTOR \_\_\_\_\_

CALIFORNIA CONTRACTORS LICENSE # \_\_\_\_\_

DATE \_\_\_\_\_

SIGNATURE \_\_\_\_\_

TITLE \_\_\_\_\_

INSULATION CONTRACTOR **ARCADE INSULATION**

CALIFORNIA CONTRACTORS LICENSE #263784

DATE 3-14-01

SIGNATURE J. H. Wood

TITLE Team Leader