

CITY OF SACRAMENTO
1231 I Street, Sacramento, CA 95814

Permit No: 0010735

Insp Area: 4

Site Address: 3436 SWEET PEA WY SAC
Parcel No: 274-0490-037 NATOMAS W 1 LOT 41

Sub-Type: NSFR
Housing (Y/N): N

CONTRACTOR
KAUFMAN AND BROAD
611 ORANGE DR
VACAVILLE CA 95687

OWNER

ARCHITECT

Nature of Work: NSFR MP1706 8 RMS 1 STORY

CONSTRUCTION LENDING AGENCY : I hereby affirm under penalty of perjury that there is a construction lending agency for the performance of the work for which this permit is issued (Sec. 3097, Civ. C).

Lender's Name _____ Lender's Address _____

LICENSED CONTRACTORS DECLARATION: I hereby affirm under penalty of perjury that I am licensed under provisions of Chapter 9 (commencing with section 7000) of Division 3 of the Business and Professions Code and my license is in full force and effect.

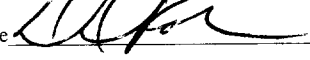
X License Class 3 License Number 761970 Date 9-20-00 Contractor Signature 

OWNER-BUILDER DECLARATION: I hereby affirm under penalty of perjury that I am exempt from the contractors License Law for the following reason (Sec. 7031.5, Business and Professions Code, any city or county which requires a permit to construct, alter, improve, demolish, or repair any structure, prior to its issuance, also requires the applicant for such permit to file a signed statement that he or she is licensed pursuant to the provisions of the Contractors License Law (Chapter 9 (commencing with Section 7000) of Division 8 of the Business and Professions Code) or that he or she is exempt therefrom and the basis for the alleged exemption. Any violation of Section 7031.5 by any applicant for a permit subjects the applicant to a civil penalty of not more than five hundred dollars (\$500.00):

____ I, as a owner of the property, or my employees with wages as their sole compensation, will do the work, and the structure is not intended or offered for sale (Sec. 7044, Business and Professional Code: The Contractors License Law does not apply to an owner of property who builds or improves thereon, and who does such work himself or herself or through his/her own employees, provided that such improvements are not intended or offered for sale. If, however, the building or improvement is sold within one year of completion, the owner-builder will have the burden of proving that he/she did not build or improve for the purpose of sale.)

____ I, as owner of the property, am exclusively contracting with licensed contractors to construct the project (Sec. 7044, Business and Professions Code) The Contractors License Law does not apply to an owner of property who builds or improves thereon, and who contracts for such projects with a contractor(s) licensed pursuant to the Contractors License Law.

____ I am exempt under Sec. _____ B & PC for this reason: _____

Date _____ Owner Signature _____

IN ISSUING THIS BUILDING PERMIT, the applicant represents, and the city relies on the representation of the applicant, that the applicant verified all measurements and locations shown on the application or accompanying drawings and that the improvement to be constructed does not violate any law or private agreement relating to permissible or prohibited locations for such improvements. This building permit does not authorize any illegal location of any improvement or the violation of any private agreement relating to location of improvements.

I certify that I have read this application and state that all information is correct. I agree to comply with all city and county ordinances and state laws relating to building construction and hereby authorize representative(s) of this city to enter upon the above mentioned property for inspection purposes.

X Date 9-20-00 Applicant/Agent Signature 

WORKER'S COMPENSATION DECLARATION: I hereby affirm under penalty of perjury one of the following declarations:

____ I have and will maintain a certificate of consent to self-insure for workers' compensation as provided for by Section 3700 of the Labor Code, for the performance of work for which the permit is issued

X I have and will maintain workers' compensation insurance, as required by Section 3700 of the Labor Code, for the performance of the work for which this permit is issued. My workers' compensation insurance carrier and policy number are:

Carrier CONTINENTAL CAS. CO. Policy Number WC188899094 Exp Date 5/1/2000

____ (This section need not be completed if the permit is for \$100 or less) I certify that in the performance of the work for which this permit is issued, I shall not employ any person in any manner so as to become subject to the workers' compensation laws of California and agree that if I should become subject to the workers' compensation provisions of Section 3700 of the Labor Code, I shall forthwith comply with those provisions.

X Date 9-20-00 Applicant Signature 

WARNING: FAILURE TO SECURE WORKER'S COMPENSATION COVERAGE IS UNLAWFUL AND SHALL SUBJECT AN EMPLOYER TO CRIMINAL PENALTIES AND CIVIL FINES UP TO ONE HUNDRED THOUSAND DOLLARS (\$100,000) IN ADDITION TO THE COST OF COMPENSATION, DAMAGES AS PROVIDED FOR IN SECTION 3706 OF THE LABOR CODE, INTEREST AND ATTORNEY'S FEE.

THIS PERMIT SHALL EXPIRE BY LIMITATION IF WORK IS NOT COMMENCED WITHIN 180 DAYS.

RESIDENTIAL SUBDIVISION BUILDING PERMIT APPLICATION

Project Address: 3436 Sweet + Pea Way Assessor Parcel #
Lot Number: 41 Subdivision Antemas West Village 1

OWNER INFORMATION:

Legal Property Owner: Kaufman Brown Phone# 707-469-2464
Owner Address: 111 Orange Dr City Vallejo State CA Zip 95687

CONTRACTOR INFORMATION:

Contractor: Kaufman Brown Lic. # 761970 Phone # 469-2464 Fax 469-2465

PROJECT INFORMATION:

Land Use Zone Occupancy Group Construction Type Fed Code
No. of Stories: 1 No. of Rooms: 7 Street Width:
1st Floor Area 1700 2nd Floor Area Basement Roof Material
AREA IN SQUARE FOOT OF:
Dwelling/Living 1700
Garage/Storage 433
Decks/Balconies 25
Carports
CITY OF SACRAMENTO PERMIT ASSISTANCE

SCOPE OF WORK: New Single Family Dwelling SEP 11 2000

RECEIVED

FOR OFFICE USE ONLY

- Information Above Complete AR Flood Waiver Required Planning Approval
Violation Files Checked Flood Elevation Certificate Required Design Review Approval
Standard Setbacks Water Development Infill Area Special Fee Districts Apply:
County Sewer

THE FOLLOWING MUST BE PROVIDED IN ORDER TO SUBMIT FOR PERMIT

- 2 COMPLETE PLOT PLANS, LEGIBLE & DRAWN TO SCALE
11 X 17 COPY OF FLOOR PLAN WITH FOLLOWING INFORMATION
a) Assessor's Parcel Number c) Owners Name
b) New Floor Area d) Project Address

Date: Received by: (staff) Permit #

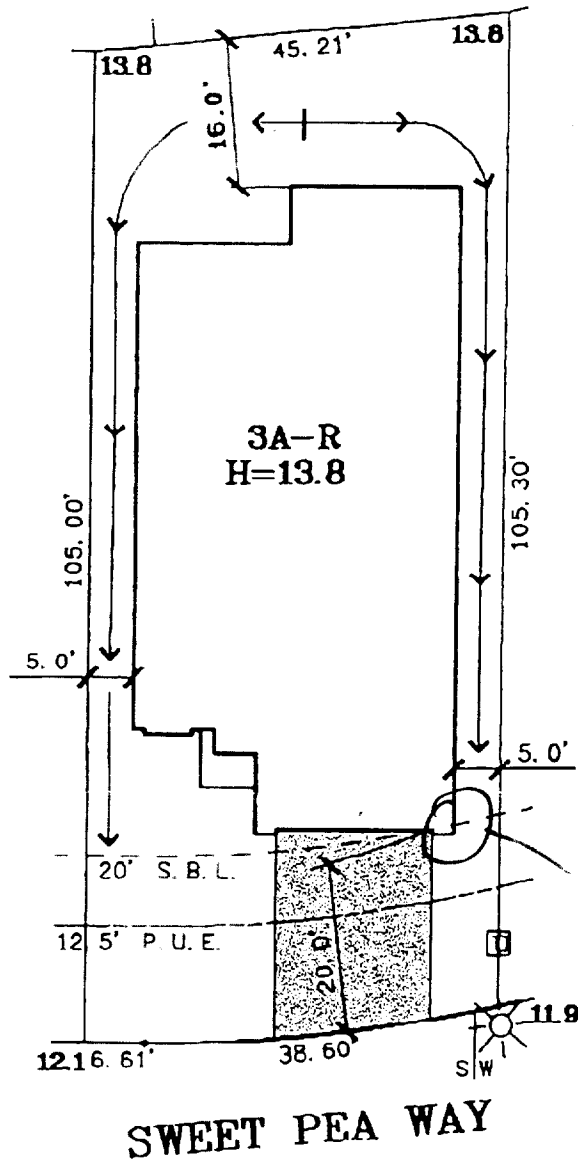

cannot encroach into 20' setback

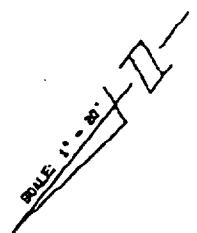

DATE: 9-18-00 REV

A.P.N.:

ADDRESS: 3498 SWEET PEA WAY

LOT AREA: 4,771 SF

LOT COVERAGE: 45%

The Splink Corporation

2590 VENTURE OAKS WAY
SACRAMENTO, CA. 95833

PH (916)925-6650 FAX (916)921-9274

NATOMAS WEST
VILLAGE 1

LOT 41
PLAN 3A

CALIFORNIA GARDENS

CITY OF SACRAMENTO, CA
CLIENT: KAUFMAN & BROAD