

CONSTRUCTION LENDING AGENCY

I hereby affirm under penalty of perjury that there is a construction lending agency for the performance of the work for which this permit is issued (Sec. 3097, Civ.C.).

Lenders Name N/A
Lenders Address _____

LICENSED CONTRACTORS DECLARATION

I hereby affirm under penalty of perjury that I am licensed under provisions of Chapter 9 (commencing with Section 7000) of Division 3 of the Business and Professions Code and my license is in full force and effect.

License Class CU5 Lic. Number 423432
Date 10-6-98 Contractor T. Rogers
(Signature)

OWNER - BUILDER DECLARATION

I hereby affirm under penalty of perjury that I am exempt from the Contractors License Law for the following reason (Sec. 7031.5, Business and Professions Code: Any city or county which requires a permit to construct, alter, improve, demolish, or repair any structure, prior to its issuance, also requires the applicant for such permit to file a signed statement that he or she is licensed pursuant to the provisions of the Contractors License Law (Chapter 9 (commencing with Section 7000) of Division 8 of the Business and Professions Code) or that he or she is exempt therefrom and the basis for the alleged exemption. Any violation of Section 7031.5 by any applicant for a permit subjects the applicant to a civil penalty of not more than five hundred dollars (\$500.00):

I, as owner of the property, or my employees with wages as their sole compensation, will do the work, and the structure is not intended or offered for sale (Sec. 7044, Business and Professions Code: The Contractors License Law does not apply to an owner of property who builds or improves thereon, and who does such work himself or herself or through his or her own employees, provided that such improvements are not intended or offered for sale. If, however, the building or improvement is sold within one year of completion, the owner-builder will have the burden of proving that he or she did not build or improve for the purpose of sale.)

I, as owner of the property, am exclusively contracting with licensed contractors to construct the project (Sec. 7044, Business and Professions Code: The Contractors License Law does not apply to an owner of property who builds or improves thereon, and who contracts for such projects with a contractor(s) licensed pursuant to the Contractors License Law).

I am exempt under Sec. _____ B & P C for this reason _____

Date 10-6-98 Owner T. Rogers
(Signature)

In issuing this building permit, the applicant represents, and the City relies on the representation of the applicant, that the applicant verified all measurements and locations shown on the application or accompanying drawings and that the improvement to be constructed does not violate any law or private agreement relating to permissible or prohibited locations for such improvements. This building permit does not authorize any illegal location of any improvement or the violation of any private agreement relating to location of improvements.

I certify that I have read this application and state that all information is correct. I agree to comply with all city and county ordinances and state laws relating to building construction and hereby authorize representative of this city to enter upon the abovementioned property for inspection purposes.

Date 10-6-98 Signature of Applicant or Agent T. Rogers

SITE ADDRESS (9445) 9445 River River Drive

ASSESSOR PARCEL NO. 9445 River River Drive

NAME OF APPLICANT Pacific Retail Trust ADDRESS 2419 Seltzer Way PERMIT NO. 95691 ZIP CODE 94631 PHONE NO. 916-321-3200

LICENSED CONTRACTOR Pacific Retail Trust BUSINESS OWNER Pacific Retail Trust

ATTACHED INTERIOR / ELECT. SINGLE FACED BILLBOARD / SUBDIVISION
 ILLUMINATED NON-ILLUMINATED PAINTED ON BUILDING LOGO
 INDIVIDUAL LETTERS POLE DOUBLE FACED
 METAL MONUMENT VINYL/GATOR FOAM
 PLASTIC PROJECTING RE-FACE
 WOODEN

SIGN COPY 6 CDC General Nutrition Center
CITY OF SACRAMENTO PERMIT SERVICES
BUILDING INSPECTION DIVISION 264-7619
WORKER'S COMPENSATION DECLARATION

I hereby affirm under penalty of perjury one of the following declarations:
 I have and will maintain a certificate of consent to self-insure for workers' compensation as provided for by Section 3700 of the Labor Code, for the performance of work for which the permit is issued.
 I have and will maintain workers' compensation insurance, as required by Section 3700 of the Labor Code, for the performance of the work for which this permit is issued. My workers' compensation insurance carrier and policy number are:
Carrier: State Fund
Policy Number: 1455554-98

(This section need not be completed if the permit is for one hundred dollars (\$100) or less) I certify that in the performance of the work for which this permit is issued, I shall not employ any person in any manner so as to become subject to the workers' compensation laws of California and agree that if I should become subject to the workers' compensation provisions of Section 3700 of the Labor Code, I shall forthwith comply with those provisions.
Date: 10-6-98 Applicant: T. Rogers
(Signature)

WARNING: FAILURE TO SECURE WORKERS' COMPENSATION COVERAGE IS ILLEGAL AND SHALL SUBJECT AN EMPLOYER TO CRIMINAL PENALTIES AND CIVIL FINES UP TO ONE HUNDRED THOUSAND DOLLARS (\$100,000) IN ADDITION TO THE COST OF COMPENSATION, DAMAGES AND ATTORNEY'S FEES.

FINAL INSPECTIONS
BUILDING INSPECTOR P. Wood DATE _____
ELECTRICAL INSPECTOR _____ DATE _____
SIGN INSPECTOR P. Wood DATE _____
CITY OF SACRAMENTO RECEIVED
DATE _____ AMOUNT _____
SIGN APPLICATION FEE 100
NEIGHBORHOOD DEVELOPMENT SERVICES
ELECTRICAL SIGN FEE _____
CITY BUSINESS LICENSE _____
OTHER _____
TOTAL FEES \$ _____

THIS PERMIT SHALL EXPIRE BY LIMITATION IF WORK AUTHORIZED IS NOT COMMENCED WITHIN 180 DAYS.

Notes Rush River Drive.

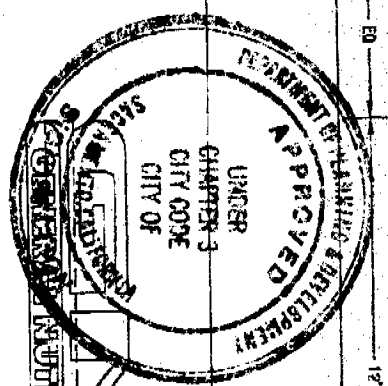

This set of plans and specifications must be kept on the job at all times and it is unlawful to make any changes or alterations from the same without written permission from the City of Sacramento Sign Section. The approval of this plan and specification shall NOT be held to permit or approve the GENERAL NUTRITION CENTER Ordinance or State Law.

All electrical work must be U.L. labeled or be of equivalent standards N.E.C. Sec. 90-6 and comply with Chapter 14, Div. 2 of Sacramento City Code. EQUIPMENT MUST BE USED AS DESIGN INTENDED AND SIGN INSTALLATIONS ARE SUBJECT TO FIELD INSPECTIONS

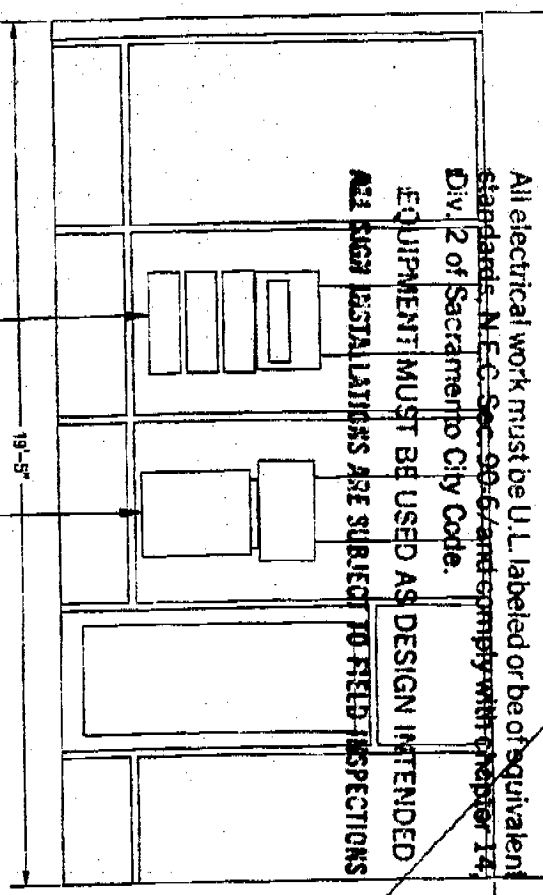

EXTERIOR STOREFRONT

NO.	DATE	BY	DESCRIPTION

GENERAL NUTRITION CENTER BUILT TO HAVE A WHITE NO. 7228 PLEXIGLAS FACE W/BLACK NEON TUBE - (15MM VTC. SMTITE/ARCON)

FILE COPY

5-20358
9809955

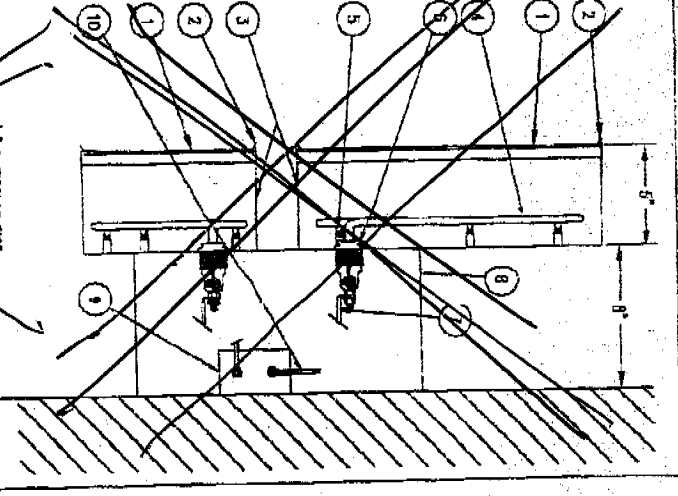

1. 1/8" PLEXIGLAS FACE
 2. TRIM
 3. ALUMINUM LETTER AND MOUNTING
 4. RETURN WELDED CONSOLE
 5. NEON TUBE
 6. 1/2" NEON TUBE SUPPORT
 7. MIDBOX ELECTRICAL BOXES
 8. 5/8" X 1/2" ALUMINUM RACKWAY W/ ALUMINUM ANGLE FRAME-ACCESS PANELS ACROSS TOP
 9. 5/8" X 1/2" TRANSFORMER WITH SOCKETRY
 10. 1/2" SEALITE ANGLE
- COLOR SCHEDULE:
 1. FACE: NEW #2418
 2. TRIM: CANT. BK/RODGE
 3. MOUNTING LETTER: BK/RODGE
 4. NEON TUBE: PHD (15MM CLN/NEON)
 5. WELDING: CREAM
- NOTE: ALL CLEARANCE REQUIRED BEHIND PEXGLAS FOR ELECTRICAL CONNECTIONS.

WEIGHT	NO. MOVIES	FRACTION	EV/16	PATTERN NO.	PAIR NUMBER	NO. PER. UNIT ASSEMBLY	SIZE

DATE	BY	DESCRIPTION

TITLE	SCALE	DATE	NO.	OF	SHEETS
GREENWAVE PROMENADE - SACRAMENTO, CA	1/2" = 1'-0"				

GNC - Prominafde
Rush river road
Sacramento, Ca

ELECTRICAL HOOK-UP INFORMATION

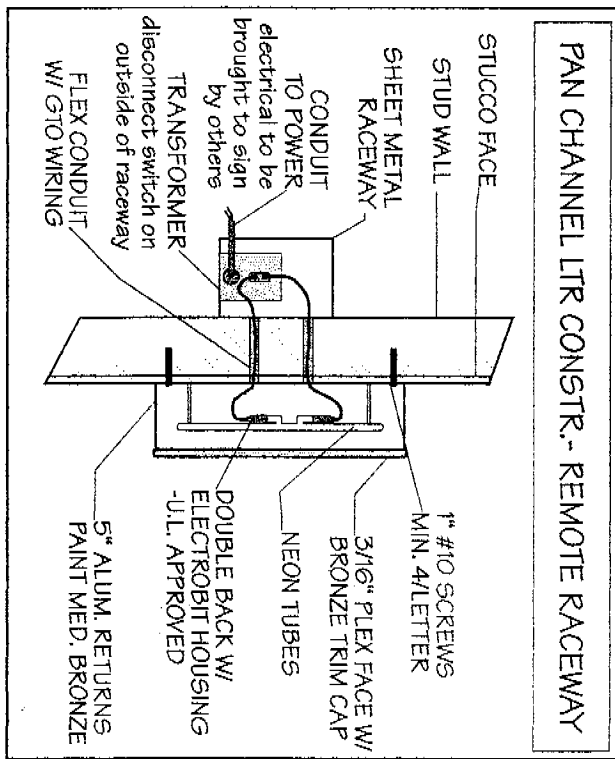

NOT TO SCALE

Promenade
Sacramento, California

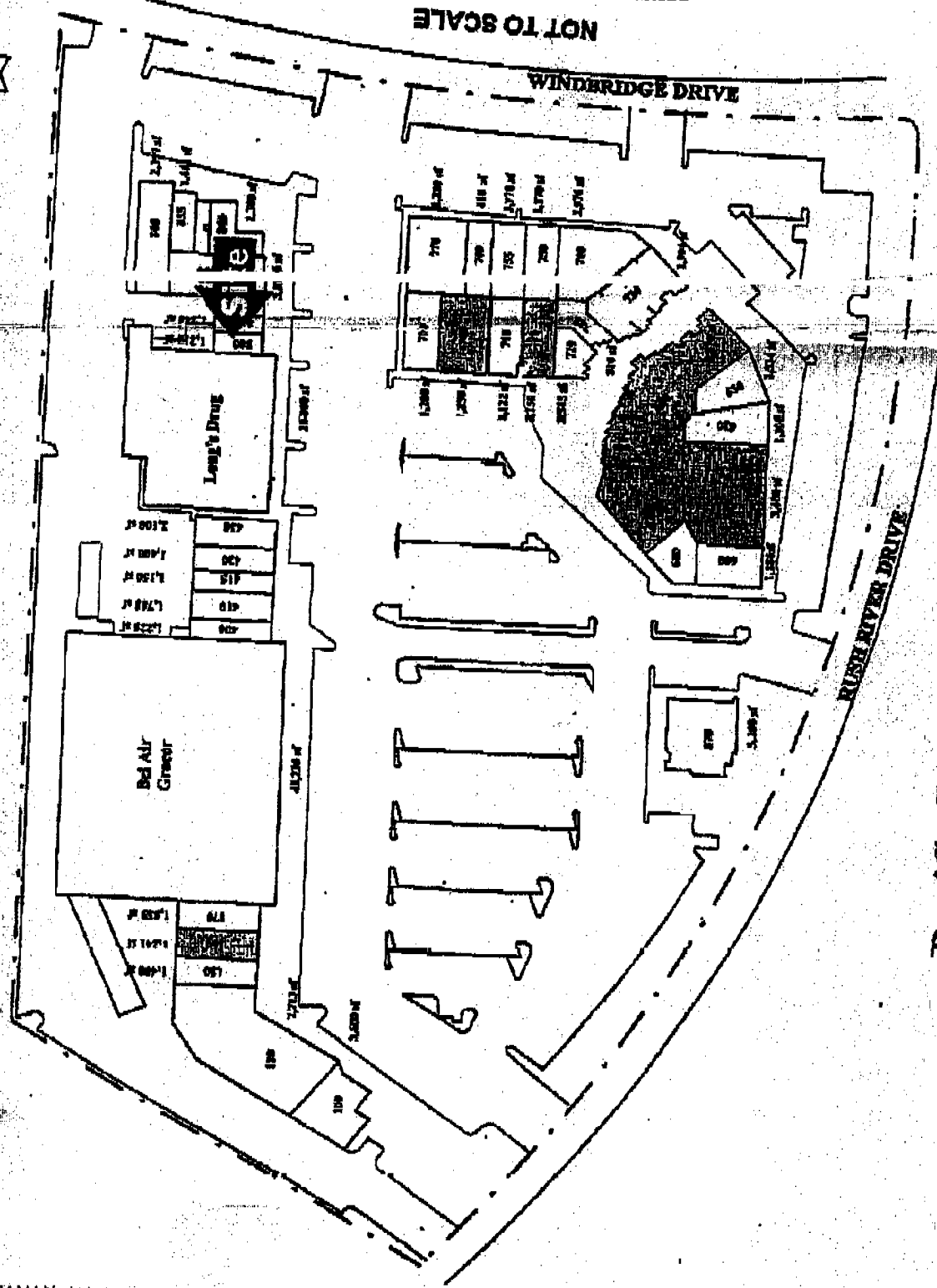

Pacific Retail Trust

Walnut Creek, California

Suite 150

1331 N. California Blvd.

- 199 Mountain Office Plaza 3,600 s.f.
- 200 Rocket Tree Value 7,710 s.f.
- 418 City of Sacramento 1,400 s.f.
- 419 Available 1,241 s.f.
- 420 Baby Discount 1,579 s.f.
- 421 Bed Air 43,230 s.f.
- 422 Uniglobe Travel 1,225 s.f.
- 423 Eyedentures 1,783 s.f.
- 424 Willow Glen 1,120 s.f.
- 425 Gypsy Books 1,400 s.f.
- 426 Jimmy Craig 2,400 s.f.
- 427 Longs Drugs Retail 16,000 s.f.
- 428 Alkaz's Florist 1,184 s.f.
- 429 Available 3,400 s.f.
- 430 Chever's Pizzeria 1,760 s.f.
- 431 Millen Michaels 1,539 s.f.
- 432 Available 6,379 s.f.
- 433 Available 1,734 s.f.
- 434 Citrus Restaurant 1,538 s.f.
- 435 Boreck & Bore 1,209 s.f.
- 436 Available 2,850 s.f.
- 437 Hollywood Mall 1,222 s.f.
- 438 Available 1,188 s.f.
- 439 Medicines Etc. 1,575 s.f.
- 440 Allstate 899 s.f.
- 441 Select Wine & Spirits 2,999 s.f.
- 442 Duck's Restaurant 2,976 s.f.
- 443 From, Clinics, etc. 1,170 s.f.
- 444 Arthur's Bookstore 1,179 s.f.
- 445 Clancy's 819 s.f.
- 446 Aid's 2,236 s.f.
- 447 Holy Trinity 1,213 s.f.
- 448 Sage Education 1,248 s.f.
- 449 Touch Per Hospital 4,027 s.f.
- 450 Enrichment-Coffee 2,389 s.f.
- 451 Pacific Foods 1,442 s.f.
- 452 Calixton One 2,397 s.f.
- 453 Bud's Physical Therapy 3,300 s.f.

EXHIBIT "D"
Site Plan

8 1 0 3 4 2