

**CITY OF SACRAMENTO**

**1231 I Street, Sacramento, CA 95814**

**Permit No: 0007919**

**Insp Area: 2**

**Site Address: 6180 HOLSTEIN WY SAC**

**Parcel No: 024-0383-016**

**Sub-Type: ASFR**

**Housing (Y/N): N**

**CONTRACTOR**

PETKUS BROS  
3068 SUNRISE BL.  
RANCHO CORDOVA CA

**OWNER**

OKAMOTO MELVIN/NORRINE  
1428 34TH AV  
SACRAMENTO CA 95822

**ARCHITECT**

**Nature of Work: PATIO COVER**

**CONSTRUCTION LENDING AGENCY:** I hereby affirm under penalty of perjury that there is a construction lending agency for the performance of the work for which this permit is issued (Sec. 3097, Civ. C).

Lender's Name \_\_\_\_\_ Lender's Address \_\_\_\_\_

**LICENSED CONTRACTORS DECLARATION:** I hereby affirm under penalty of perjury that I am licensed under provisions of Chapter 9 (commencing with section 7000) of Division 3 of the Business and Professions Code and my license is in full force and effect.

X License Class B License Number 670242 Date 7-12-00 Contractor Signature [Signature]

**OWNER-BUILDER DECLARATION:** I hereby affirm under penalty of perjury that I am exempt from the contractors License Law for the following reason (Sec. 7031.5, Business and Professions Code; any city or county which requires a permit to construct, alter, improve, demolish, or repair any structure, prior to its issuance, also requires the applicant for such permit to file a signed statement that he or she is licensed pursuant to the provisions of the Contractors License Law (Chapter 9 (commencing with Section 7000) of Division 8 of the Business and Professions Code) or that he or she is exempt therefrom and the basis for the alleged exemption. Any violation of Section 7031.5 by any applicant for a permit subjects the applicant to a civil penalty of not more than five hundred dollars (\$500.00);

\_\_\_\_ I, as a owner of the property, or my employees with wages as their sole compensation, will do the work, and the structure is not intended or offered for sale (Sec. 7044, Business and Professional Code: The Contractors License Law does not apply to an owner of property who builds or improves thereon, and who does such work himself or herself or through his/her own employees, provided that such improvements are not intended or offered for sale. If, however, the building or improvement is sold within one year of completion, the owner-builder will have the burden of proving that he/she did not build or improve for the purpose of sale.)

\_\_\_\_ I, as owner of the property, am exclusively contracting with licensed contractors to construct the project (Sec. 7044, Business and Professions Code: The Contractors License Law does not apply to an owner of property who builds or improves thereon, and who contracts for such projects with a contractor(s) licensed pursuant to the Contractors License Law).

\_\_\_\_ I am exempt under Sec. \_\_\_\_\_ B & PC for this reason: \_\_\_\_\_

Date \_\_\_\_\_ Owner Signature \_\_\_\_\_

**IN ISSUING THIS BUILDING PERMIT,** the applicant represents, and the city relies on the representation of the applicant, that the applicant verified all measurements and locations shown on the application or accompanying drawings and that the improvement to be constructed does not violate any law or private agreement relating to permissible or prohibited locations for such improvements. This building permit does not authorize any illegal location of any improvement or the violation of any private agreement relating to location of improvements.

I certify that I have read this application and state that all information is correct. I agree to comply with all city and county ordinances and state laws relating to building construction and hereby authorize representative(s) of this city to enter upon the abovementioned property for inspection purposes.

X Date 7-12-00 Applicant/Agent Signature [Signature]

**WORKER'S COMPENSATION DECLARATION:** I hereby affirm under penalty of perjury one of the following declarations:

\_\_\_\_ I have and will maintain a certificate of consent to self-insure for workers' compensation as provided for by Section 3700 of the Labor Code, for the performance of work for which the permit is issued.

\_\_\_\_ I have and will maintain workers' compensation insurance, as required by Section 3700 of the Labor Code, for the performance of the work for which this permit is issued. My workers' compensation insurance carrier and policy number are:

Carrier STATE FUND Policy Number 713-U-502 Exp Date 10-1-00

\_\_\_\_ (This section need not be completed if the permit is for \$100 or less. I shall not employ any person in any manner so as to become subject to the workers' compensation laws of California and agree that if I should become subject to the workers' compensation provisions of Section 3700 of the Labor Code, I shall forthwith comply with those provisions.

X Date 7-12-00 Applicant Signature [Signature]

**WARNING: FAILURE TO SECURE WORKER'S COMPENSATION COVERAGE IS UNLAWFUL AND SHALL SUBJECT AN EMPLOYER TO CRIMINAL PENALTIES AND CIVIL FINES UP TO ONE HUNDRED THOUSAND DOLLARS (\$100,000) IN ADDITION TO THE COST OF COMPENSATION, DAMAGES AS PROVIDED FOR IN SECTION 3706 OF THE LABOR CODE, INTEREST AND ATTORNEY'S FEE.**

**THIS PERMIT SHALL EXPIRE BY LIMITATION IF WORK IS NOT COMMENCED WITHIN 180 DAYS.**

MEL OKamoto  
6180 HOLSTEIN way

Sacto CA. 95831

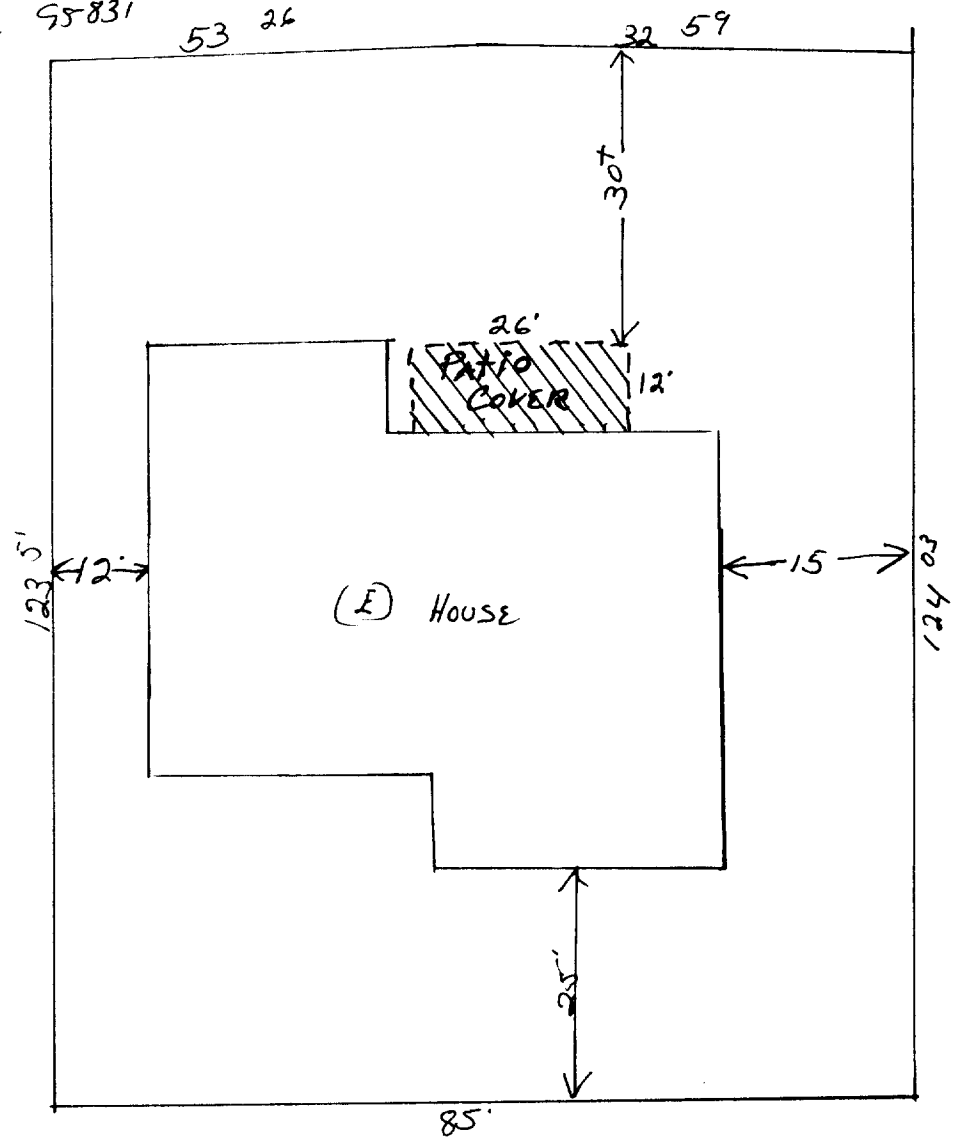

ISS  
JUL  
CITY OF  
DEVELOPMENT

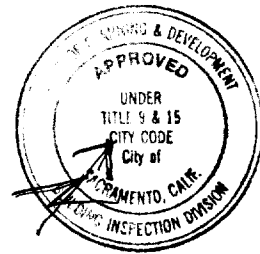

←————— HOLSTEIN way —————→



DESIGN: CONNECTION TO TOP OR BOTTOM OF EAVE FOR SUPPORT OF LATTICE COVER, PATIO COVER OR SUNROOM STRUCTURES INSTALLED PER REQUIREMENTS OF 1997 UBC APPENDIX 31 DIV. III

LOADS

LIVE LOAD = 10, 20 PSF

DEAD LOAD = 5 PSF (COVER)

WIND: 80 mph -  $F_{UP} = 13$  PSF

DEAD LOAD (EAVE) = 10 PSF

FIND MAX ALLOWABLE LOADS TO 2x4 EAVE (#2DF).

$$V_{ALL} = \frac{1.5(3.5)(95)(1.25)}{1.5} = 416\#$$

$$M_{ALL} = \frac{3.06 \text{ in}^3 (875) \sqrt{\text{size}} \text{ LDF}}{12} (1.15) (1.25) = 418 \text{ in} \cdot \#$$

$$\Delta_{ALL} = \frac{L(12)}{R 180}$$

$$V_{ACT} = P + WL \leq 416\# \Rightarrow P_{MAX} = 416\# - WL \quad (1)$$

$$M_{ACT} = \frac{WL^2}{2} + PL \leq 418 \Rightarrow P_{MAX} = \frac{418 - \frac{WL^2}{2}}{L} \quad (2)$$

$$\Delta_{ACT} = \left[ \frac{WL^4}{8EI} + \frac{PL^3}{3EI} \right] (1728) \leq \frac{L(12)}{180} = \frac{L}{15}$$

$$\Rightarrow P_{MAX} = \left[ \frac{L}{15(1728)} - \frac{WL^4}{8EI} \right] \left( \frac{3EI}{L^3} \right) \quad (3)$$

$$EI = 8575000$$

USE  $P_{MIN}$  FROM 3 CASES

FIND MAX TRIB WIDTH FROM COVER

$$P_{MIN} = \text{TRIB WIDTH} (LL + 5\text{PSF}) \left( \frac{\text{SPACING}}{12} \right)$$

$$\text{MAX TRIB WIDTH} = \frac{P \left( \frac{12}{\text{SPACING}} \right)}{(LL + 5\text{PSF})}$$

MAX DIST. TO FIRST PATIO COVER = 2 (TRIBUTARY WIDTH) SUPPORT.

PACIFIC CONSULTING ENGINEERS  
2100 BELL AVE., SUITE 145  
SACRAMENTO, CA 95833

SEE COMPUTER PRINT OUT NEXT PAGE

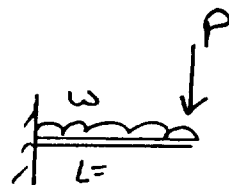

**TABLE 1: MAXIMUM POINT LOAD TO 2x4 #2 DF EAVE**

EAVE LENGTH (INCHES)	10 PSF ROOF LIVE LOAD									
	16 " RAFTER SPACING 26.67 = w, PLF			LOAD TO USE	MAX TRIB WIDTH FROM COVER	24 " RAFTER SPACING 40.00 = w, PLF			LOAD TO USE	MAX TRIB WIDTH FROM COVER
	(V)	(M)	(DEFL)			(V)	(M)	(DEFL)		
12	388.96	405.37	982.48	388.96	19.45	375.63	398.70	977.48	375.63	12.965278
16	380.07	296.25	968.77	296.25	14.81	362.29	287.36	956.92	287.36	9.8749367
24	362.29	182.68	912.48	182.68	9.13	335.63	169.35	872.48	169.35	6.089464

EAVE LENGTH (INCHES)	20 PSF ROOF LIVE LOAD									
	16 " RAFTER SPACING 40 = w, PLF			LOAD TO USE	MAX TRIB WIDTH FROM COVER	24 " RAFTER SPACING 60 = w, PLF			LOAD TO USE	MAX TRIB WIDTH FROM COVER
	(V)	(M)	(DEFL)			(V)	(M)	(DEFL)		
12	375.63	398.70	977.48	375.63	11.27	355.63	388.70	969.98	355.63	7.51
16	362.29	287.36	956.92	287.36	8.62	335.63	274.03	939.14	274.03	5.75
24	335.63	169.35	872.48	169.35	5.08	295.63	149.35	812.48	149.35	3.39

	2x4 #2 DF (BASIC)	1.25	1.33	2x6 #2 DF
V(all)	332.50	415.63	442.23	
M(all)	334.96	418.70	445.50	
EI	8575000			

CONNECTION OF BRACKET TO EAVE RAFTER

$T_{MAX} = 389\#$  (IF BRACKET MOUNTED TO BOTTOM OF EAVE.)

TALL (#10 WS w/ 1 1/2" PENET) = (95#/IN) (1.15") = 142 #/screw

MIN # OF SCREWS =  $\frac{389\#}{142} = 2.73 \Rightarrow$

USE (3) #10 W.S. FROM BRACKET TO EAVE RAFTER

CONNECTION OF LEDGER TO BRACKET

$V_{MAX} = 389\#$

$V_{ALL} (\#10 WS) = (143\#/screw) (1.25) = 178.75\#/screw$

MIN # OF SCREWS =  $\frac{389}{179} = 2.17 \Rightarrow$

USE (3) #10 W.S. FROM BRACKET TO LEDGER



