

CITY OF SACRAMENTO

1231 I Street, Sacramento, CA 95814

Permit No: 0306574

Insp Area: 4

Thos Bros: 277 E3

Site Address: 840 TURNSTONE DR SAC

Parcel No: 250-0390-026

Sub-Type: RES

Housing (Y/N): N

CONTRACTOR

OWNER

SISOMMOUT DARIPHONE/SOUK
840 TURNSTONE DR
SACRAMENTO CA 95834

ARCHITECT

Nature of Work: TEAR-OFF AND RE-ROOF W/ MIN 30 YR LAM DIM COMP

CONSTRUCTION LENDING AGENCY: I hereby affirm under penalty of perjury that there is a construction lending agency for the performance of the work for which this permit is issued (Sec. 3097, Civ. C).

Lender's Name _____ Lender's Address _____

LICENSED CONTRACTORS DECLARATION: I hereby affirm under penalty of perjury that I am licensed under provisions of Chapter 9 (commencing with section 7000) of Division 3 of the Business and Professions Code and my license is in full force and effect.

License Class _____ License Number _____ Date _____ Contractor Signature _____

OWNER-BUILDER DECLARATION: I hereby affirm under penalty of perjury that I am exempt from the contractors License Law for the following reason (Sec. 7031.5, Business and Professions Code; any city or county which requires a permit to construct, alter, improve, demolish, or repair any structure, prior to its issuance, also requires the applicant for such permit to file a signed statement that he or she is licensed pursuant to the provisions of the Contractors License Law (Chapter 9 (commencing with Section 7000) of Division 8 of the Business and Professions Code) or that he or she is exempt therefrom and the basis for the alleged exemption. Any violation of Section 7031.5 by any applicant for a permit subjects the applicant to a civil penalty of not more than five hundred dollars (\$500.00);

I, as a owner of the property, or my employees with wages as their sole compensation, will do the work, and the structure is not intended or offered for sale (Sec. 7044, Business and Professional Code: The Contractors License Law does not apply to an owner of property who builds or improves thereon, and who does such work himself or herself or through his/her own employees, provided that such improvements are not intended or offered for sale. If, however, the building or improvement is sold within one year of completion, the owner-builder will have the burden of proving that he/she did not build or improve for the purpose of sale.)

I, as owner of the property, am exclusively contracting with licensed contractors to construct the project (Sec. 7044, Business and Professions Code: The Contractors License Law does not apply to an owner of property who builds or improves thereon, and who contracts for such projects with a contractor(s) licensed pursuant to the Contractors License Law).

I am exempt under Sec. _____ B & PC for this reason: _____

Date 5/13/03 Owner Signature 

IN ISSUING THIS BUILDING PERMIT, the applicant represents, and the city relies on the representation of the applicant, that the applicant verified all measurements and locations shown on the application or accompanying drawings and that the improvement to be constructed does not violate any law or private agreement relating to permissible or prohibited locations for such improvements. This building permit does not authorize any illegal location of any improvement or the violation of any private agreement relating to location of improvements.

I certify that I have read this application and state that all information is correct. I agree to comply with all city and county ordinances and state laws relating to building construction and hereby authorize representative(s) of this city to enter upon the abovementioned property for inspection purposes.

Date _____ Applicant/Agent Signature _____

WORKER'S COMPENSATION DECLARATION: I hereby affirm under penalty of perjury one of the following declarations:

I have and will maintain a certificate of consent to self-insure for workers' compensation as provided for by Section 3700 of the Labor Code, for the performance of work for which the permit is issued.

I have and will maintain workers' compensation insurance, as required by Section 3700 of the Labor Code, for the performance of the work for which this permit is issued. My workers' compensation insurance carrier and policy number are:

Carrier _____ Policy Number _____ Exp Date _____

(This section need not be completed if the permit is for \$100 or less) I certify that in the performance of the work for which this permit is issued, I shall not employ any person in any manner so as to become subject to the workers' compensation laws of California and agree that if I should become subject to the workers' compensation provisions of Section 3700 of the Labor Code, I shall forthwith comply with those provisions.

Date 5/13/03 Applicant Signature 

WARNING: FAILURE TO SECURE WORKER'S COMPENSATION COVERAGE IS UNLAWFUL AND SHALL SUBJECT AN EMPLOYER TO CRIMINAL PENALTIES AND CIVIL FINES UP TO ONE HUNDRED THOUSAND DOLLARS (\$100,000) IN ADDITION TO THE COST OF COMPENSATION, DAMAGES AS PROVIDED FOR IN SECTION 3706 OF THE LABOR CODE, INTEREST AND ATTORNEY'S FEE.

THIS PERMIT SHALL EXPIRE BY LIMITATION IF WORK IS NOT COMMENCED WITHIN 180 DAYS.

ROOFING QUESTIONNAIRE

Applicant's name: PANG KANTHATHIN Phone: 952-7396
Project Address: 840 TURNSTONE DR. (APN: 250-0390-026)

Please check the appropriate boxes. Only check a box if it accurately and completely describes your proposed work, otherwise leave boxes blank.

1. ROOFING TYPE

a. The existing roofing material is composition shingle, wood shake or shingle, tile or metal. The new roofing material shall be:

Existing	Proposed	
<input checked="" type="checkbox"/>	<input checked="" type="checkbox"/>	30 25 year laminated dimensional composition
<input type="checkbox"/>	<input type="checkbox"/>	wood shake or shingle
<input type="checkbox"/>	<input type="checkbox"/>	tile
<input type="checkbox"/>	<input type="checkbox"/>	metal that simulates one of the above listed materials

b. The existing roofing material is built up, foam or membrane with a roof pitch of 2:12 or less. The new roofing material shall be:

Existing	Proposed	
<input type="checkbox"/>	<input type="checkbox"/>	Built up
<input type="checkbox"/>	<input type="checkbox"/>	Foam
<input type="checkbox"/>	<input type="checkbox"/>	Membrane

2. GUTTERS

a. The existing gutters are fascia gutters.

There is no change proposed to existing gutters.
 New fascia gutters shall be provided.
 Gutters shall be repaired and/or replaced to match existing.

b. The existing gutters are Ogee gutters.

There is no change proposed to existing gutters.
 New Ogee gutters shall be provided.
 Gutters shall be repaired and/or replaced to match existing.

c. There are no existing gutters.

No new gutters are proposed.
 New Ogee gutters shall be provided.

3. RAFTER TAILS

a. There are no exposed rafter tails.

b. There are exposed rafter tails.

There is no change or cutting proposed to existing rafter tails.
 Rafter tails shall be repaired and replaced to match existing.

By signing below, the applicant certifies that this form accurately describes the proposed work.

Applicant's signature: [Signature] Date: 5/13/03

For City Staff use only

Counter Staff PAUL REED

In a DR District Meets DR criteria? Yes No (route to DR staff)
 In a P area or listed (route to P staff)
 Not in DR/P area

Expanded North Area

Permit # 0306574
Initialized



CITY OF SACRAMENTO RE-ROOF PERMIT DESIGN REVIEW GUIDE

COMPOSITION ROOFING MATERIALS

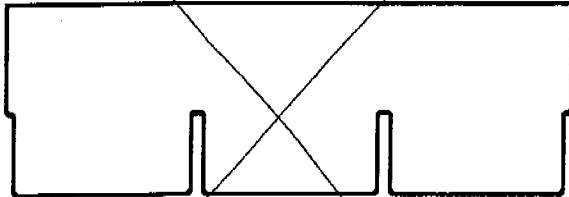

Three-tab NOT ALLOWED
in Design Review Areas

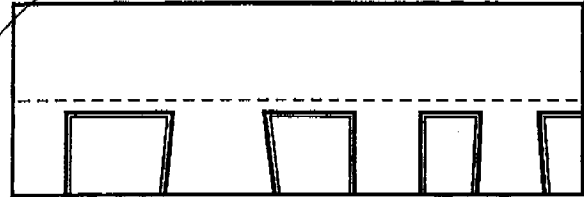

Laminated Dimensional
minimum 30-year required

GUTTER TYPES

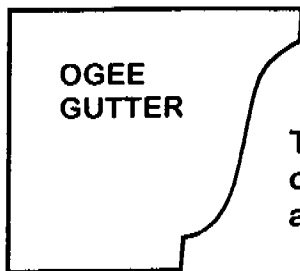

Typical of
older style
architecture

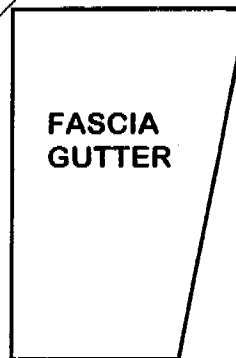

Typical of
newer 'modern'
architecture

RAFTER TAILS

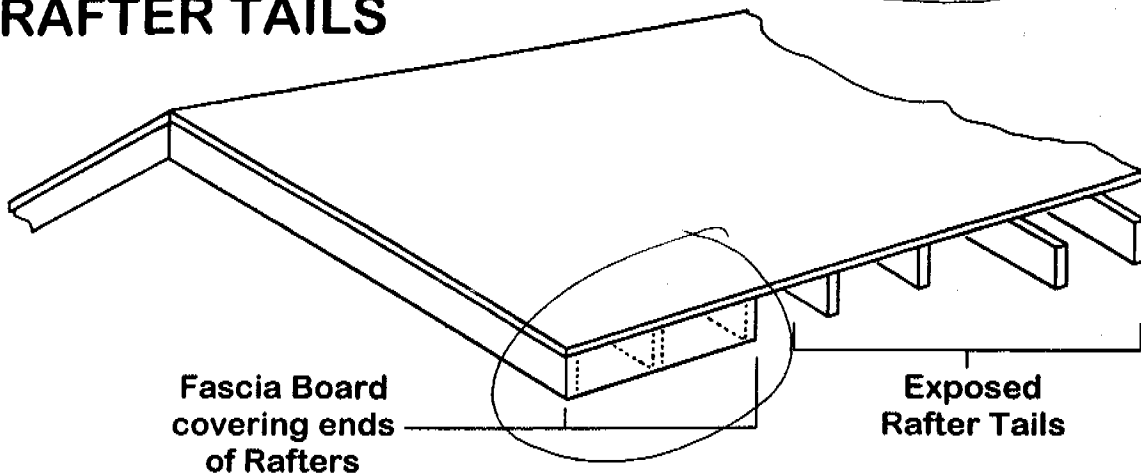

Fascia Board
covering ends
of Rafters

Exposed
Rafter Tails