

CITY OF SACRAMENTO  
1231 T Street, Sacramento, CA 95814

Permit No: 0103730  
Insp Area: 4

Site Address: 3612 VIADER WY SAC  
Parcel No: 225-1300-023 GTWAY W 3 LOT 34

Sub-Type: NSFR  
Housing (Y/N): N

CONTRACTOR  
MOURIER JOHN CONSTRUCTION INC  
1830 VERNON ST  
SUITE 9 95687

OWNER

ARCHITECT

Nature of Work: MP 2653 2 STORY 11 ROOM SFR

**CONSTRUCTION LENDING AGENCY:** I hereby affirm under penalty of perjury that there is a construction lending agency for the performance of the work for which this permit is issued (Sec. 3097, Civ. C.)

Lender's Name \_\_\_\_\_ Lender's Address \_\_\_\_\_

**LICENSED CONTRACTORS DECLARATION:** I hereby affirm under penalty of perjury that I am licensed under provisions of Chapter 9 (commencing with section 7000) of Division 3 of the Business and Professions Code and my license is in full force and effect.

License Class D License Number 673004 Date 4/2/01 Contractor Signature N. Collins

**OWNER-BUILDER DECLARATION:** I hereby affirm under penalty of perjury that I am exempt from the contractors License Law for the following reason (Sec. 7031.5, Business and Professions Code, any city or county which requires a permit to construct, alter, improve, demolish, or repair any structure, prior to its issuance, also requires the applicant for such permit to file a signed statement that he or she is licensed pursuant to the provisions of the Contractors License Law (Chapter 9 (commencing with Section 7000) of Division 8 of the Business and Professions Code) or that he or she is exempt therefrom; and the basis for the alleged exemption. Any violation of Section 7031.5 by any applicant for a permit subjects the applicant to a civil penalty of not more than five hundred dollars (\$500.00):

\_\_\_\_ I, as a owner of the property, or my employees with wages as their sole compensation, will do the work, and the structure is not intended or offered for sale (Sec. 7044, Business and Professional Code). The Contractors License Law does not apply to an owner of property who builds or improves thereon, and who does such work himself or herself or through his/her own employees, provided that such improvements are not intended or offered for sale. If, however, the building or improvement is sold within one year of completion, the owner-builder will have the burden of proving that he/she did not build or improve for the purpose of sale.

\_\_\_\_ I, as owner of the property, am exclusively contracting with licensed contractors to construct the project (Sec. 7044, Business and Professions Code). The Contractors License Law does not apply to an owner of property who builds or improves thereon, and who contracts for such projects with a contractor(s) licensed pursuant to the Contractors License Law.

\_\_\_\_ I am exempt under Sec. \_\_\_\_\_ B & PC for this reason: \_\_\_\_\_

Date \_\_\_\_\_ Owner Signature \_\_\_\_\_

**IN ISSUING THIS BUILDING PERMIT,** the applicant represents, and the city relies on the representation of the applicant, that the applicant verified all measurements and locations shown on the application or accompanying drawings and that the improvement to be constructed does not violate any law or private agreement relating to permissible or prohibited locations for such improvements. This building permit does not authorize any illegal location of any improvement or the violation of any private agreement relating to location of improvements.

I certify that I have read this application and state that all information is correct. I agree to comply with all city and county ordinances and state laws relating to building construction and hereby authorize representative(s) of this city to enter upon the abovementioned property for inspection purposes.

Date 4/2/01 Applicant/Agent Signature N. Collins

**WORKER'S COMPENSATION DECLARATION:** I hereby affirm under penalty of perjury one of the following declarations:

\_\_\_\_ I have and will maintain a certificate of consent to self-insure for workers' compensation as provided for by Section 3700 of the Labor Code, for the performance of work for which the permit is issued.

I have and will maintain workers' compensation insurance, as required by Section 3700 of the Labor Code, for the performance of the work for which this permit is issued. My workers' compensation insurance carrier and policy number are:

Carrier STATE COMPENSATION INS FUND Policy Number 156326600 Exp Date 10/01/2001

\_\_\_\_ (This section need not be completed if the permit is for \$100 or less) I certify that in the performance of the work for which this permit is issued, I shall not employ any person in any manner so as to become subject to the workers' compensation laws of California and agree that if I should become subject to the workers' compensation provisions of Section 3700 of the Labor Code, I shall forthwith comply with those provisions.

Date 4/2/01 Applicant Signature N. Collins

WARNING: FAILURE TO SECURE WORKER'S COMPENSATION COVERAGE IS UNLAWFUL AND SHALL SUBJECT AN EMPLOYER TO CRIMINAL PENALTIES AND CIVIL FINES UP TO ONE HUNDRED THOUSAND DOLLARS (\$100,000) IN ADDITION TO THE COST OF COMPENSATION, DAMAGES AS PROVIDED FOR IN SECTION 3706 OF THE LABOR CODE, INTEREST AND ATTORNEY'S FEE.

**THIS PERMIT SHALL EXPIRE BY LIMITATION IF WORK IS NOT COMMENCED WITHIN 180 DAYS.**

### RESIDENTIAL BUILDING PERMIT APPLICATION

- New Construction    
  Addition    
  Remodels    
  Other

Project Address: 3612 Viader Way     Assessor Parcel # 225-1

**OWNER INFORMATION:**

Legal Property Owner: John MAUBIER Construction     Phone # (916) 969-2842  
 Owner Address: 1830 VERNON STREET, #9     City Roseville     State Ca.     Zip 95678

**CONTRACTOR INFORMATION:**

Contractor: J.M.C.     Lic. # 613004     Phone # 969-2842     Fax# 782-8903

**PROJECT INFORMATION:**

Land Use Zone R14     Occupancy Group R3     Construction Type VN     Fed Code 14  
 No. of stories: 2     No. of rooms: 11     Street width: \_\_\_\_\_  
 1<sup>st</sup> Floor Area \_\_\_\_\_     2<sup>nd</sup> Floor Area \_\_\_\_\_     Basement \_\_\_\_\_     Roof Material \_\_\_\_\_

AREA IN SQUARE FOOT OF:	EXISTING	NEW
Dwelling/Living	_____	<u>2653</u>
Garage/Storage	_____	<u>584</u>
Decks/Balconies	_____	<u>60</u>
Carports	_____	_____

SCOPE OF WORK: \_\_\_\_\_

**FOR OFFICE USE ONLY**

- |   |   |  |
|---|---|--|
| <input type="checkbox"/> Information above complete | <input type="checkbox"/> AR Flood Waiver required             | <input type="checkbox"/> Planning Approval           |
| <input type="checkbox"/> Violation files checked    | <input type="checkbox"/> Flood Elevation Certificate Required | <input type="checkbox"/> Design Review Approval      |
| <input type="checkbox"/> Standard setbacks          | <input type="checkbox"/> Water Development Infill Area        | <input type="checkbox"/> Special Fee Districts Apply |
| <input type="checkbox"/> County Sewer               |   |  |

#### NEW STRUCTURES & ADDITIONS

◆ THE FOLLOWING MUST BE PROVIDED IN ORDER TO SUBMIT FOR PLAN REVIEW

- |   |   |
|---|---|
| <input type="checkbox"/> 2 COMPLETE PLANS, LEGIBLE & DRAWN TO SCALE   | ◆ Plans to include: site plan, floor plan, elevations, roof/ceiling plan, foundation and structural framing details, and structural calculations for non-conforming structures. |
| <input type="checkbox"/> 3 SETS IF PROJECT IS IN A DESIGN REVIEW AREA |   |
| <input type="checkbox"/> Title 24 Energy Compliance documentation     | <input type="checkbox"/> 11" x 17" copy of floor plan for County Assessor   |
| <input type="checkbox"/> Grading and Erosion Control Questionnaire    | <input type="checkbox"/> Plan Review Fees   |

Date: \_\_\_\_\_

Received by: (staff) \_\_\_\_\_





JEM

10/8/01

PLAN 2653-R2FE

01-1329

JOB: JMC HOME'S  
PLAN 2653-GATEWAY WEST

- DETAILS IN RESPONSE TO FIELD INSP.

No. 937 811E  
Engineer's Computation Pad

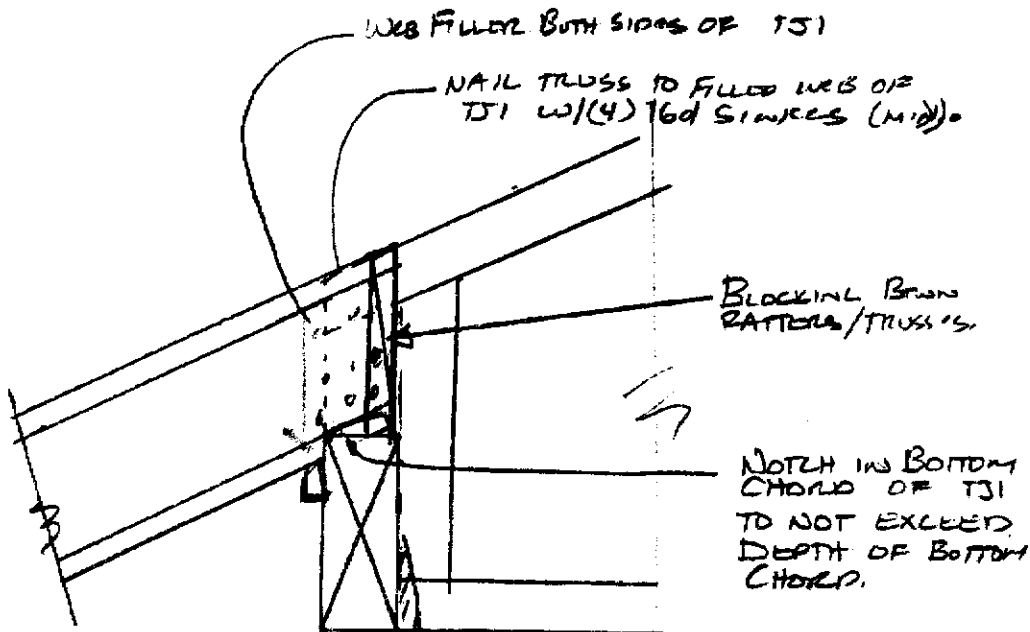

RAFTERS & BEAM OVER STAIRS

NTS

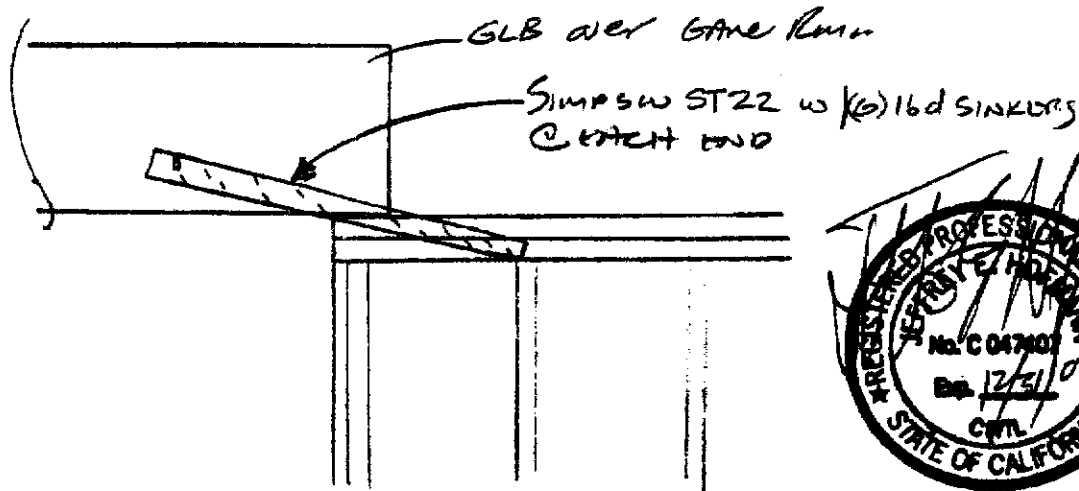

BEAM TO WALL STRAP - GLB OVER GAME ROOM

NTS

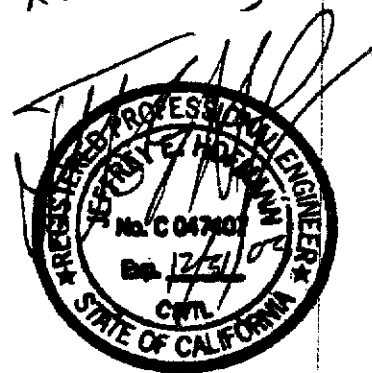

PACIFIC CONSULTING ENGINEERS  
8160 BELL AVE., SUITE 148  
SACRAMENTO, CA 95828

# GATEWAY WEST VILLAGE 3



**VAIDER WAY**

0.5' FILE

56.49'

106.55'

108.01'

60.02'

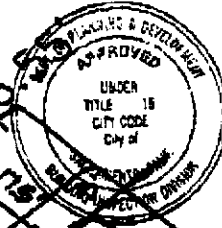

This set of plans and specifications must be kept on the job at all times and it is unlawful to make any changes or alterations from the same without written permission from the Building Inspection Division. The approval of this plan and specification SHALL NOT be held to permit or approve the violation of any City Ordinance or State Law.

**LANDSCAPING NOTES:**

1. ALL "STREET-TREES" MUST BE PLACED ALONG STREET FRONTAGE AT AN AVERAGE OF 10'-0" TO 30'-0" O.C.
2. ALL "STREET-TREES" SPECIES MUST BE PER GATEWAY WEST "STREET-TREE" MATRIX TABLE FOR STREET(S) BORDERING LOT - NO. EXCEPTIONS

**LOT: 34 SITE ADDRESS: 3612 VAIDER WAY #0103730R**

WHEN USED FOR SALES OR CONTRACT PURPOSES THIS DOCUMENT DOES NOT GUARANTEE ANY DIMENSIONS, DISTANCES, BEARINGS OR SETBACKS. JMC RESERVES THE RIGHT TO MAKE CHANGES AT ANY TIME WITHOUT PRIOR NOTICE AND IS NOT RESPONSIBLE FOR MISQUANTITIES OR DIFFERENCES IN ACTUAL OR "AS-BUILT" LOT CHARACTERISTICS.

SEAL: 7-08'	APR
LOT: 34	
GW-P34 JK 3-2-01	

APR	

**3-CAR R**  
**JMC HOMES**