

# RESOLUTION NO. 2004-118

ADOPTED BY THE SACRAMENTO CITY COUNCIL

ON DATE OF FEB 24 2004

## RESOLUTION TO APPROVE PEDESTRIAN FRIENDLY STREET STANDARDS BE IT RESOLVED BY THE COUNCIL OF THE CITY OF SACRAMENTO:

1. The Pedestrian Friendly Street Standards shown in the attached Resolution, to Amend Section Five of the General Plan, Resolution No. \_\_\_\_\_, are hereby approved.
2. The city's street system should encourage alternate mode use, especially walking and bicycling, by working toward a balance of all street users. To achieve this, the city has identified the following objectives for the city's streets:
  - a. Residential streets and street networks should be designed to discourage speeds above 25 mph.
  - b. Residential street networks should be designed to encourage only neighborhood traffic and should seek to minimize traffic volumes on residential streets.
  - c. Street design should enhance and improve the pedestrian safety and comfort and encourage non-motorized travel modes.
  - d. Employ traffic calming measures when the size and/or shape of a residential subdivision project limits the number of alternative designs.
  - e. Discourage parking on sidewalks.
  - f. Enhance and beautify the streetscape and pedestrian environment by bringing landscaping closer to the street.
  - g. Balance street design so that it does not favor motorized traffic.
  - h. Streets should not be barriers to personal interaction.
3. To assist in the implementation of the Pedestrian Friendly Street Standards, a number of Implementation objectives have been defined. These include:
  - a. City and landowners will work to meet the Goals of the standards in a way that is compatible with the project.
  - b. Allow flexibility in the application of city standards to avoid affecting housing densities, specifically in medium density zones.
  - c. Avoid adding undue delay or design cost to the project review process.

  
MAYOR

ATTEST:

  
CITY CLERK

---

### FOR CITY CLERK USE ONLY

RESOLUTION NO.: 2004-118

DATE ADOPTED: FEB 24 2004

**RESOLUTION NO. 2003-287**

ADOPTED BY THE SACRAMENTO CITY COUNCIL

ON DATE OF MAY 13 2003

**RESOLUTION FOR CONCEPTUAL APPROVAL OF PEDESTRIAN FRIENDLY STREET STANDARDS REVISIONS**

**BE IT RESOLVED BY THE COUNCIL OF THE CITY OF SACRAMENTO:**

1. Approve, in concept, the recommended changes to the street standards (Exhibit A).
2. Direct staff to prepare the appropriate changes to the relevant policy documents needed to implement the new street standards and return for final City Council approval.
3. Direct staff to revise street standard variance procedures to include consideration of enhancing and improving the pedestrian environment and encouraging alternate mode use.

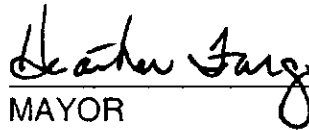
  
MAYOR

ATTEST:

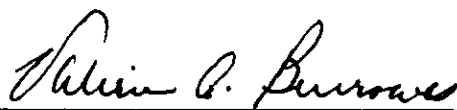
  
CITY CLERK

**FOR CITY CLERK USE ONLY**

RESOLUTION NO.: 2003-287

DATE ADOPTED: MAY 13 2003

# CONCEPTUAL STREET STANDARDS

## TYPICAL CROSS-SECTIONS

City of Sacramento

### LOCAL RESIDENTIAL STREETS

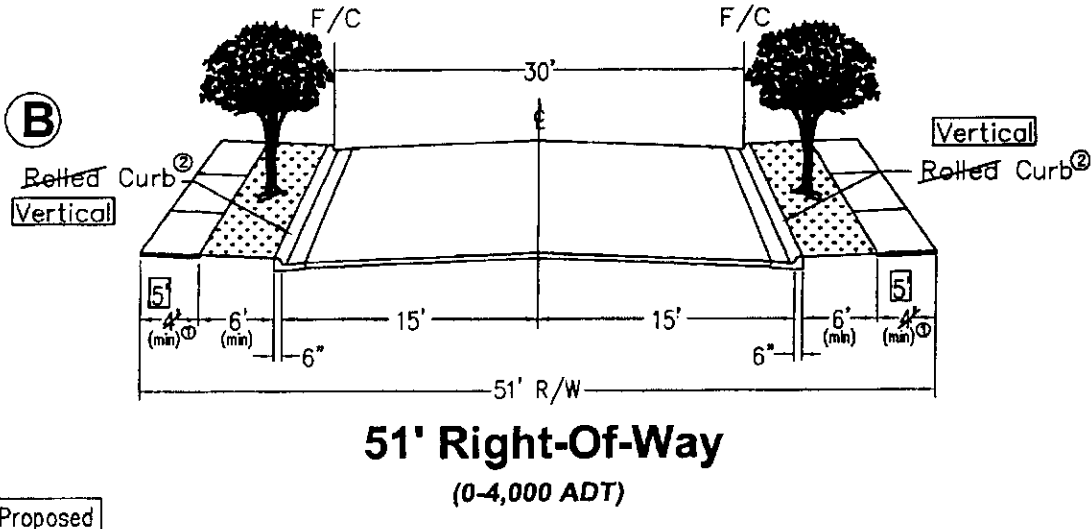
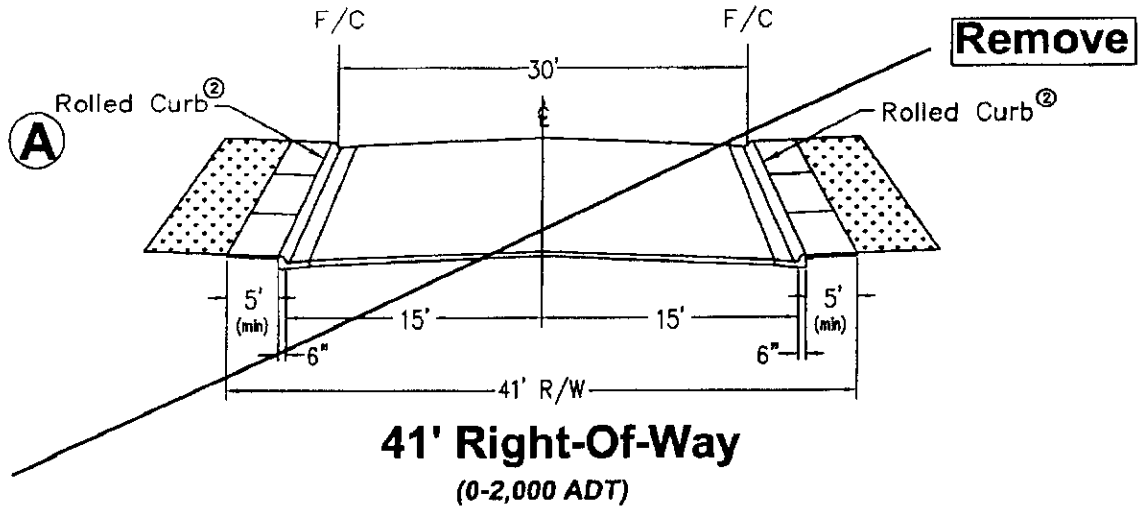

MINOR DEVIATIONS FROM THE STANDARDS REQUIRE THE APPROVAL OF THE DIRECTOR OF PUBLIC WORKS OR THE DESIGNEE.

Revised: 2/7/2003

S:\TS Wk Grp Docs\Develop Svcs\Drawings\pro\_at\_side\2003 St Stds - LOCAL RESIDENTIAL.dwg RLW

FOR CITY CLERK USE ONLY

RESOLUTION NO.: 2003-287  
DATE ADOPTED: MAY 13 2003

# CONCEPTUAL STREET STANDARDS TYPICAL CROSS-SECTIONS

City of Sacramento

## LOCAL NON-RESIDENTIAL STREETS

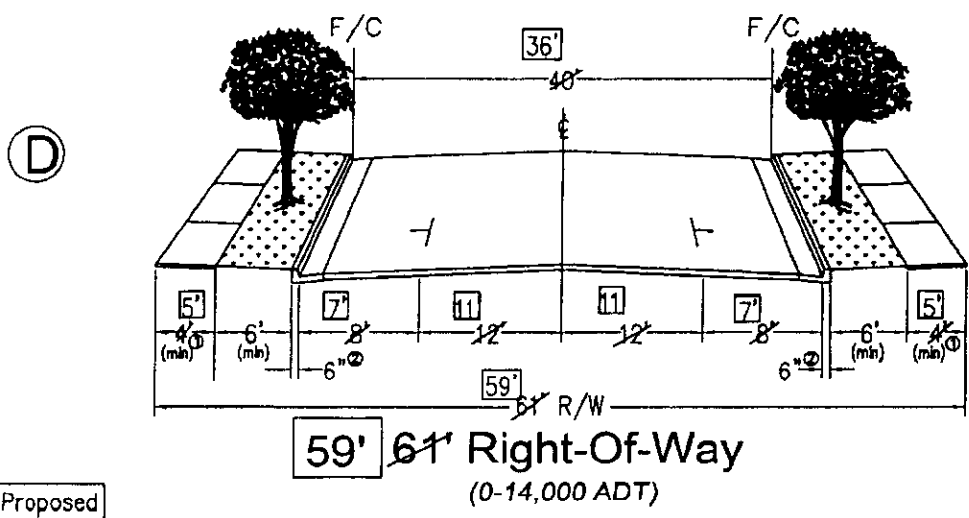
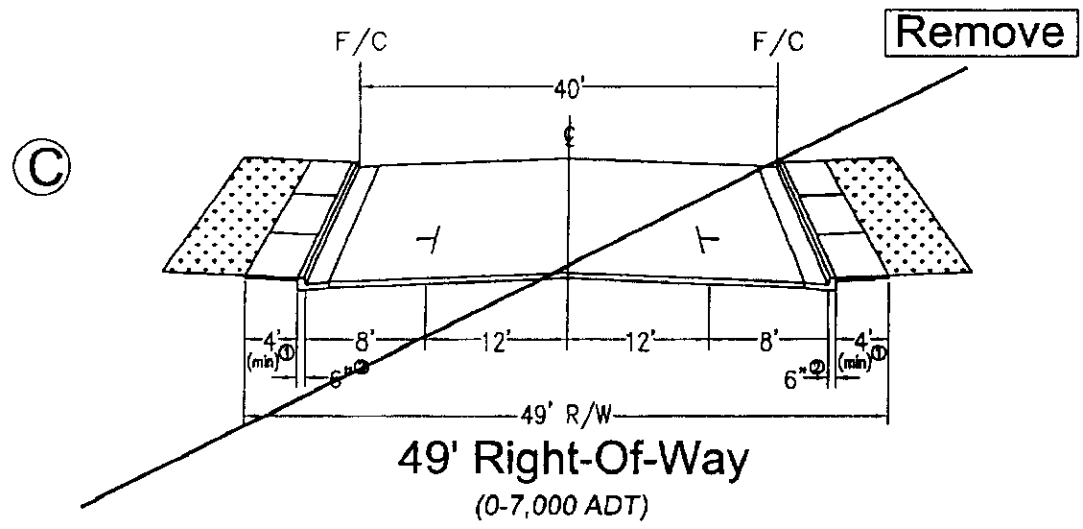

MINOR DEVIATIONS FROM THE STANDARDS REQUIRE THE APPROVAL OF THE DIRECTOR OF PUBLIC WORKS OR THE DESIGNEE.

REVISED: 2/11/2003

S:\IS Wk Grp Docs\Develop Svcs\Drawings\pro\_at\_std\2003 St Stds - Local non-resid.dwg RLJ

FOR CITY CLERK USE ONLY

RESOLUTION NO.: 2003-287

DATE ADOPTED: MAY 13 2003

# CONCEPTUAL STREET STANDARDS

## TYPICAL CROSS-SECTIONS

City of Sacramento

### COLLECTOR STREETS

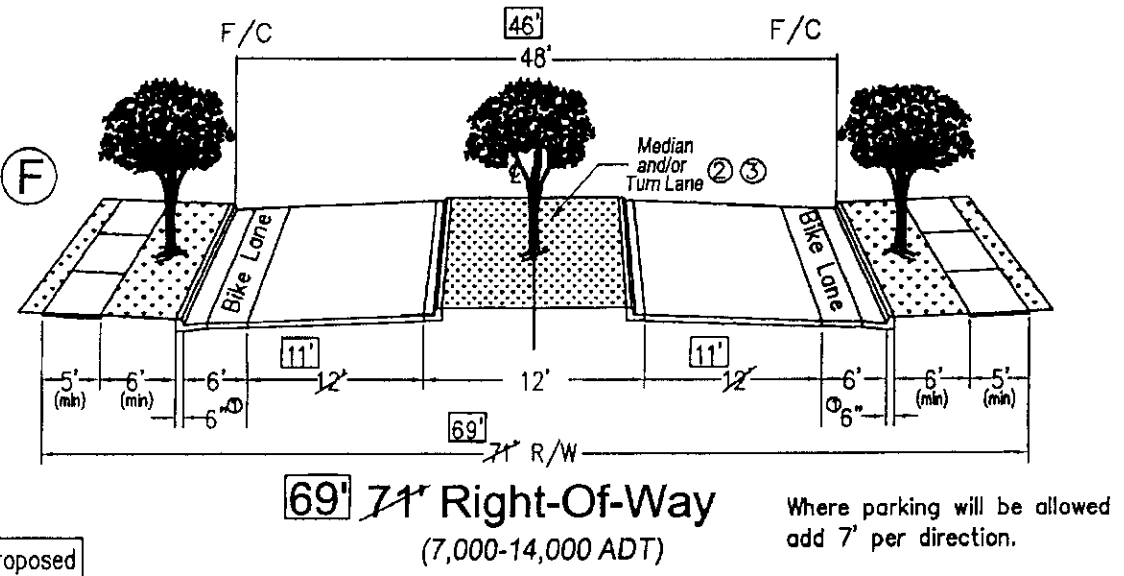
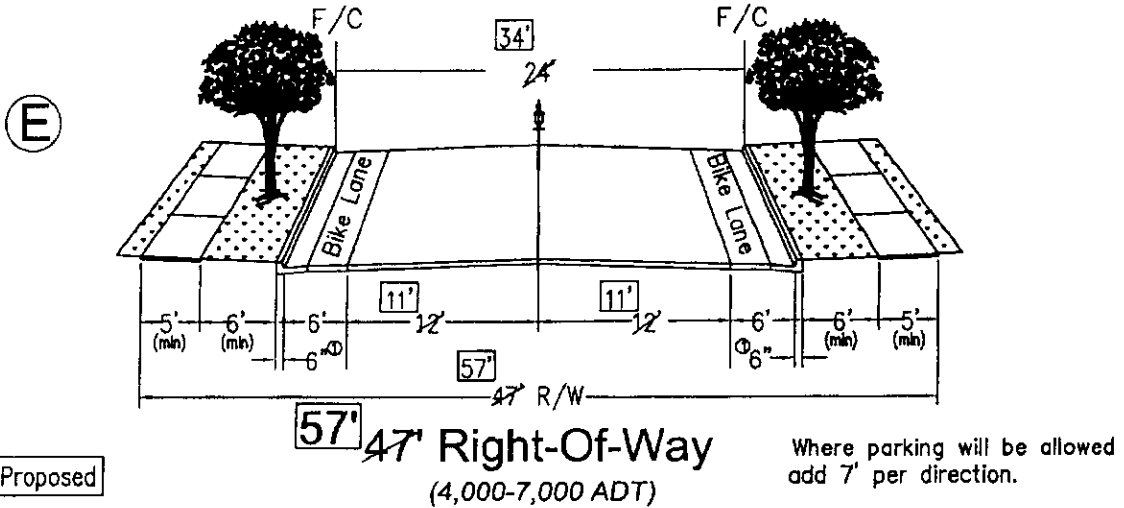

- ① - Dimensions shown are approximate.
  - ② - The Director of Public Works or the designee will determine whether a turn lane or a landscaped median is installed.
  - ③ - Median and median landscaping to be mountable.
- MINOR DEVIATIONS FROM THE STANDARDS REQUIRE THE APPROVAL OF THE DIRECTOR OF PUBLIC WORKS OR THE DESIGNEE.

REVISED: 2/7/2003

S:\TS Ntk Grp Docs\Develop Svcs\Drawings\proj\_at\_atide\2003 St Stds - COLLECTOR.dwg RLM

FOR CITY CLERK USE ONLY

RESOLUTION NO.: 2003-287

DATE ADOPTED: MAY 13 2003

# CONCEPTUAL STREET STANDARDS

## TYPICAL CROSS-SECTIONS

City of Sacramento

### ARTERIAL STREETS

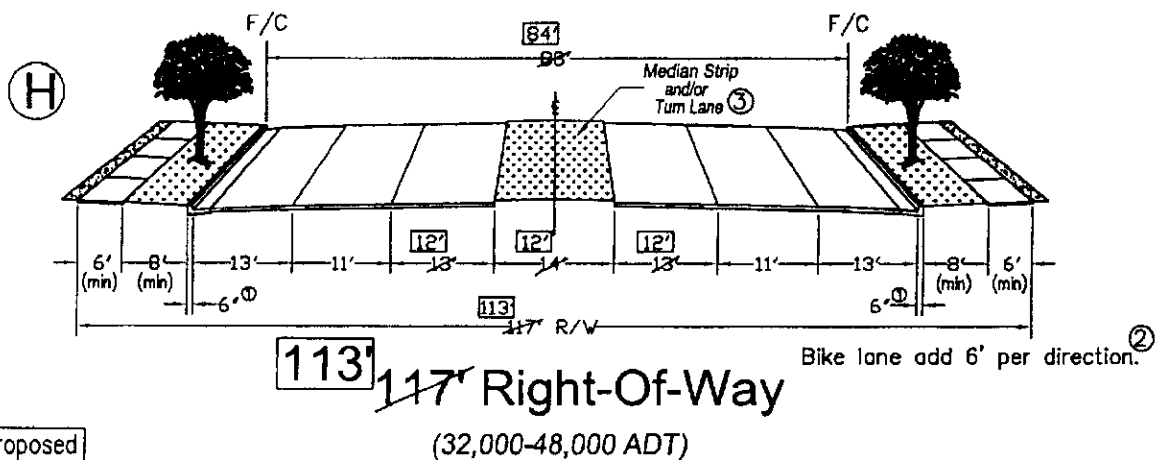
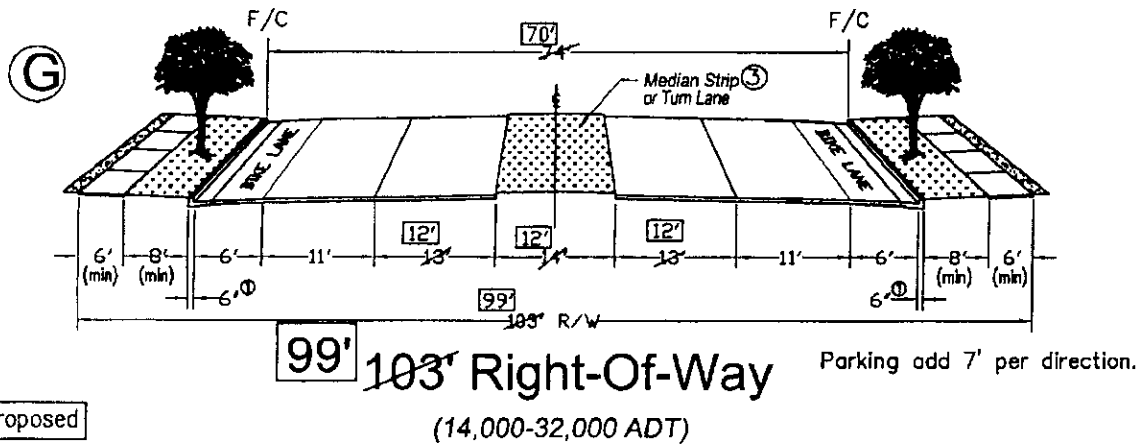

- ① - Dimensions shown are approximate. See Vertical Curb Section under additional notes.
- ② - Bike lanes will be added per the Bikeway Master Plan And On All segments in North Natomas.
- ③ - The Director of Public Works or designee will determine whether a turn lane or a landscaped median is installed.

MINOR DEVIATIONS FROM THE STANDARDS REQUIRE THE APPROVAL OF THE DIRECTOR OF PUBLIC WORKS OR THE DESIGNEE.

Revised: 2/7/2003

S:\TS Wk Grp Docs\Develop Svcs\Drawings\pro\_st\_std\2003 St Std -ARTERIAL.dwg RLJ

FOR CITY CLERK USE ONLY

RESOLUTION NO.: 2003-287

DATE ADOPTED: MAY 13 2003

**PEDESTRIAN FRIENDLY STREET STANDARDS**

**Exhibit B**

**SUMMARY OF ACTIONS**

**Presented to Sacramento City Council  
May 13, 2003**

- ✓ Walkable Communities Presentation to City Council, by Dan Burden May, 2002
- ✓ Public Works report to City Council regarding Street Standards Revisions June, 2002
- ✓ Street Standards Revision Team Initiated (with weekly meetings) August, 2002
- ✓ Outreach Consultant hired September, 2002
- ✓ Coordination meeting with Fire and Parks and Recreation Departments September, 2002
- ✓ Councilmember briefings October, 2002
- ✓ Executive team briefing October, 2002
- ✓ Meeting for Developer and Technical Stakeholders November, 2002
- ✓ Community meeting December, 2002
- ✓ Meetings with Specific Developers December, 2002
- ✓ City Council adopts "Pedestrian Safety Guidelines" January, 2002
- ✓ Meetings with SMUD regarding use of the Public Utility Easement. January, 2003
- ✓ Coordination meeting with Planning and Building Department January, 2003
- ✓ Presentation to Disabilities Advisory Committee January, 2003
- ✓ Meetings with North Natomas Working Group February, 2003
- ✓ Meetings with Specific Developer to test standards on real maps. February, 2003
- ✓ Meeting with SMUD and Joint Utilities Committee April, 2003
- ✓ Second Executive Team Briefing April, 2003
- ✓ **City Council Conceptual Approval and Direction to Staff May 2003**

---

**FOR CITY CLERK USE ONLY**

RESOLUTION NO.: 2003-287

DATE ADOPTED: MAY 13 2003

# TIMELINE OF EVENTS FOR DEVELOPMENT PROJECTS

EXHIBIT C

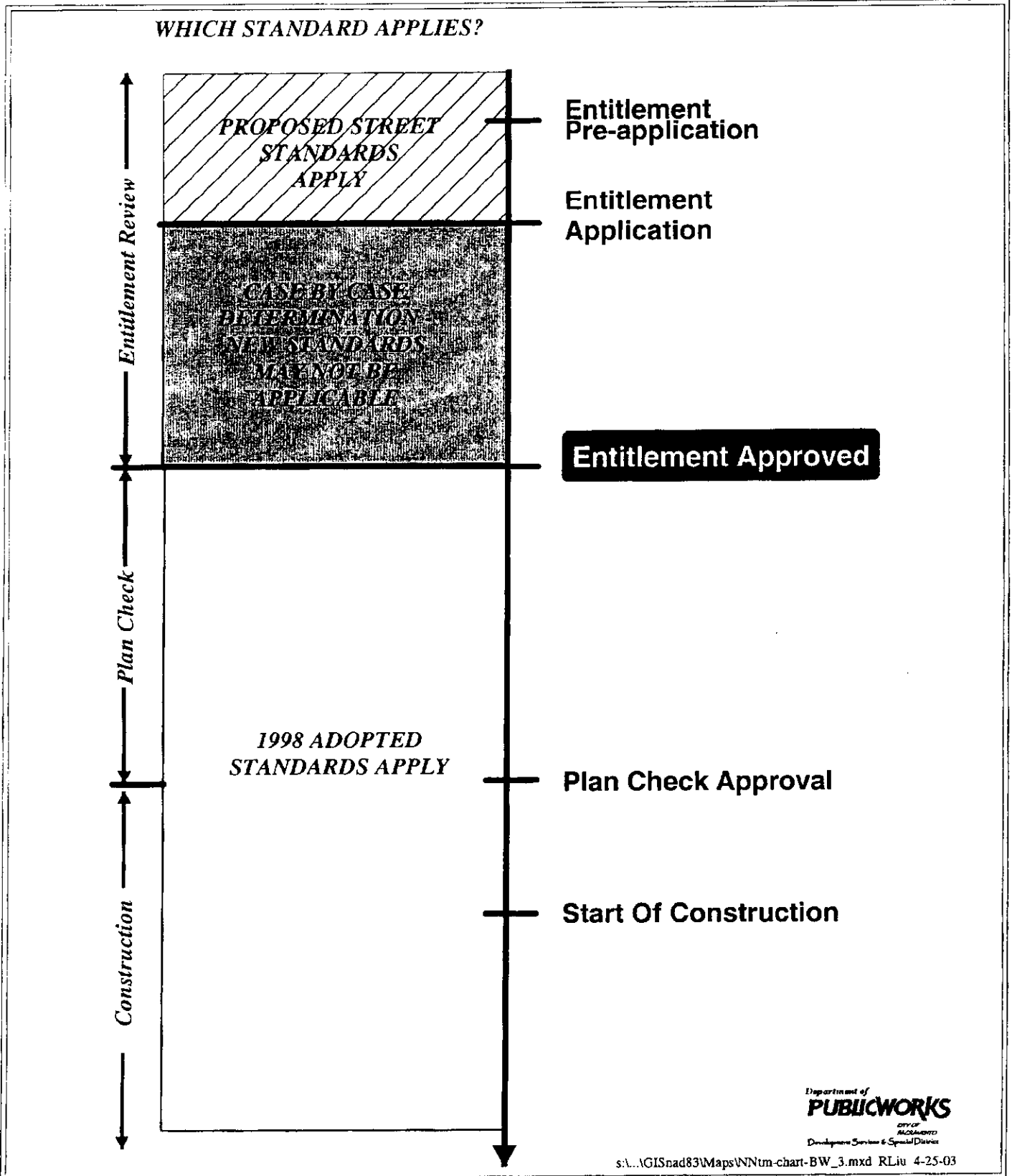

FOR CITY CLERK USE ONLY

RESOLUTION NO.: 2003-287  
 DATE ADOPTED: MAY 13 2003