

CITY OF SACRAMENTO
1231 I Street, Sacramento, CA 95814

Permit No: 0311768

Insp Area: 4

Thos Bros: 277-J4

Site Address: 2868 FRIGATEBIRD DR SAC
Parcel No: PARKVIEW VIL. 7 LOT 69

Sub-Type: NSFR
Housing (Y/N): N

CONTRACTOR
RYLAND HOMES
3005 DOUGLAS BL. STE. 115
ROSEVILLE CA. 95661

OWNER

ARCHITECT

Nature of Work: MP 2319 2 STORY 9 ROOM SFR

CONSTRUCTION LENDING AGENCY: I hereby affirm under penalty of perjury that there is a construction lending agency for the performance of the work for which this permit is issued (Sec. 3097, Civ. C).

Lender's Name _____ Lender's Address _____

LICENSED CONTRACTORS DECLARATION: I hereby affirm under penalty of perjury that I am licensed under provisions of Chapter 9 (commencing with section 7000) of Division 3 of the Business and Professions Code and my license is in full force and effect.

License Class B License Number 054648 Date 8.11.03 Contractor Signature [Signature]

OWNER-BUILDER DECLARATION: I hereby affirm under penalty of perjury that I am exempt from the contractors License Law for the following reason (Sec. 7031.5, Business and Professions Code; any city or county which requires a permit to construct, alter, improve, demolish, or repair any structure, prior to its issuance, also requires the applicant for such permit to file a signed statement that he or she is licensed pursuant to the provisions of the Contractors License Law (Chapter 9 (commencing with Section 7000) of Division 8 of the Business and Professions Code) or that he or she is exempt therefrom and the basis for the alleged exemption. Any violation of Section 7031.5 by any applicant for a permit subjects the applicant to a civil penalty of not more than five hundred dollars (\$500.00);

____ I, as a owner of the property, or my employees with wages as their sole compensation, will do the work, and the structure is not intended or offered for sale (Sec. 7044, Business and Professional Code: The Contractors License Law does not apply to an owner of property who builds or improves thereon, and who does such work himself or herself or through his/her own employees, provided that such improvements are not intended or offered for sale. If, however, the building or improvement is sold within one year of completion, the owner-builder will have the burden of proving that he/she did not build or improve for the purpose of sale.)

____ I, as owner of the property, am exclusively contracting with licensed contractors to construct the project (Sec. 7044, Business and Professions Code: The Contractors License Law does not apply to an owner of property who builds or improves thereon, and who contracts for such projects with a contractor(s) licensed pursuant to the Contractors License Law).

____ I am exempt under Sec. _____ B & PC for this reason: _____

Date _____ Owner Signature _____

PAID
CITY OF SACRAMENTO
AUG 11 2003
PERMIT CENTER

IN ISSUING THIS BUILDING PERMIT, the applicant represents, and the city relies on the representation of the applicant that the applicant verified all measurements and locations shown on the application or accompanying drawings and that the improvements to be constructed does not violate any law or private agreement relating to permissible or prohibited locations for such improvements. This building permit does not authorize any illegal location of any improvement or the violation of any private agreement relating to location of improvements.

I certify that I have read this application and state that all information is correct. I agree to comply with all city and county ordinances and state laws relating to building construction and hereby authorize representative(s) of this city to enter upon the aforementioned property for inspection purposes.

Date 8.11.03 Applicant/Agent Signature [Signature]

WORKER'S COMPENSATION DECLARATION: I hereby affirm under penalty of perjury one of the following declarations:

____ I have and will maintain a certificate of consent to self-insure for workers' compensation as provided for by Section 3700 of the Labor Code, for the performance of work for which the permit is issued.

I have and will maintain workers' compensation insurance, as required by Section 3700 of the Labor Code, for the performance of the work for which this permit is issued. My workers' compensation insurance carrier and policy number are:

Carrier AMERICAN HOME ASSURANCE Policy Number AOS WC7085227 Exp Date 06/01/2003

____ (This section need not be completed if the permit is for \$100 or less) I certify that in the performance of the work for which this permit is issued, I shall not employ any person in any manner so as to become subject to the workers' compensation laws of California and agree that if I should become subject to the workers' compensation provisions of Section 3700 of the Labor Code, I shall forthwith comply with those provisions.

Date 8.11.03 Applicant Signature [Signature]

WARNING: FAILURE TO SECURE WORKER'S COMPENSATION COVERAGE IS UNLAWFUL AND SHALL SUBJECT AN EMPLOYER TO CRIMINAL PENALTIES AND CIVIL FINES UP TO ONE HUNDRED THOUSAND DOLLARS (\$100,000) IN ADDITION TO THE COST OF COMPENSATION, DAMAGES AS PROVIDED FOR IN SECTION 3706 OF THE LABOR CODE, INTEREST AND ATTORNEY'S FEE.

THIS PERMIT SHALL EXPIRE BY LIMITATION IF WORK IS NOT COMMENCED WITHIN 180 DAYS.

Project Address: 2868 FRIGATE BIRD DR.

Assessor Parcel # _____

Lot Number: 69

Subdivision Parkview V7 V8 V18

OWNER INFORMATION:

Legal Property Owner: Ryland Homes

Phone# 997-7743

Owner Address: 3005 Douglas Blvd 115 City Roseville

State CA

Zip 95661

CONTRACTOR INFORMATION:

Contractor: Ryland Homes

Lic. # 54648

Phone # 997-7743

Fax 784-9805

PROJECT INFORMATION: PLAN THREE - MP 2319

Land Use Zone RIA Occupancy Group R3 Construction Type YN Fed Code 1A

No. of Stories: 2 No. of Rooms: 9 Street Width: 41'

1st Floor Area 1168 2nd Floor Area 1151 Basement _____ Roof Material Tile

AREA IN SQUARE FOOT OF:

Dwelling/Living 2319

Garage/Storage 454

Decks/Balconies _____

Carports _____

SCOPE OF WORK: SFD.

- Information Above Complete
- Violation Files Checked
- Standard Setbacks
- County Sewer

- AR Flood Waiver Required
- Flood Elevation Certificate Required
- Water Development Infill Area

- Planning Approval
- Design Review Approval
- Special Fee Districts Apply:

THE FOLLOWING MUST BE PROVIDED IN ORDER TO SUBMIT FOR PERMIT--

- 2 COMPLETE PLOT PLANS, LEGIBLE & DRAWN TO SCALE
- 11 X 17 COPY OF FLOOR PLAN WITH FOLLOWING INFORMATION
 - a) Assessor's Parcel Number
 - b) New Floor Area
 - c) Owners Name
 - d) Project Address

Date: _____

Received by: (staff) _____

Permit # _____

510 008
 COUNTY SANITATION DISTRICT 1
 SACRAMENTO REGIONAL COUNTY SANITATION DISTRICT

69PV

SEWER IMPACT FEE
 PERMIT AND CALCULATION
 SA
 30 JULY 03

APPLICATION NO: City
 GENERAL INFORMATION
 BLDG PERMIT NO.
 THIS PERMIT GOOD ONLY WHEN
 VALIDATED BY THE CASHIER
 Paid Thru SMD
 2003-00647
 PAID
 30 JULY 03

THIS PERMIT TO CONNECT EXPIRES
 ONE YEAR FROM DATE OF ISSUANCE

FEE CALCULATION BUILDING USE

INSPECTION	RESIDENTIAL	MF	COMMERCIAL USE
CSD-1	1853	<input checked="" type="checkbox"/>	
SRCSD	5255	<input type="checkbox"/>	
CONSTRUCTION			
IN-LIEU			
TOTAL FEE	7108		

APN: 225-1900-083

DESCRIPTION/ SUBDIVISION: Parkview Village 7 LOT 69

PROPERTY ADDRESS: 2868 Frigate Bird Dr.

OWNER: Ryland Homes

MAILING ADDRESS: 3005 Douglas Blvd #115

CITY-STATE-ZIP: Roseville 95661 PHONE: 997-7743

ADDITIONAL FEES MAY BE DUE IF CHANGES IN USE INCREASE SEWER IMPACT

APPLICANT SIGNATURE: Linda Steinfeldt 997-7743

CONSOLIDATED UTILITY BILLING USE ONLY

69PV

Natomas Unified School District
1901 Arena Blvd. • Sacramento, CA 95834
Phone 916/567-5468 • Fax 916/567-5470

CERTIFICATION OF COMPLIANCE

SCHOOL DISTRICT DEVELOPMENT FEES

PART I: TO BE COMPLETED BY APPLICANT

Property Owner's Name	Ryland Homes		
Owner's Address	3005 Douglas Blvd #115 Roseville, 95661		
Project Address	2868 Frigate Bird Dr.		
Parcel Number	Master Parcel 225-0180-006, 225-0180-046, 225-0180-0047		
Subdivision Name	Parkview Village 7		
Number of Units	ONE		
Print Applicant's Name	Linda Steinfeldt	Applicant's Signature	
Title of Applicant	Construction Coordinator	Telephone Number	997-7743
Date			

PART II: TO BE COMPLETED BY BUILDING DEPARTMENT

Plan Identification Number	2319		
Building Type (Check One)	<input checked="" type="checkbox"/> Residential <input type="checkbox"/> Apartment/Condominium <input type="checkbox"/> Commercial/Industrial		
Square Feet of Chargeable Building Area	2319		
Signature		Date	7-26-03
Title	BC		

PART III: TO BE COMPLETED BY NATOMAS UNIFIED SCHOOL DISTRICT

District Certification Number	04.124
Fees Collected:	
Residential:	2319 Sq. Ft. X \$ 3.22 = \$ 7467.18
Apartment/Condominium:	Sq. Ft. X \$ = \$
Commercial/Industrial:	Sq. Ft. X \$ = \$

NOTICE TO APPLICANT: Pursuant to government code section 66020 (d), this will serve to notify you that the 90-day approval period in which you may protest the fees, or other payment identified above, will begin to run on the date in which the building or installation permit for this project is issued, or on which they are paid to the District, or to another public entity authorized to collect them on behalf of the District, whichever is earlier.

Applicant Signature: Date: 7.15.03

This certification covers only the amount of square footage indicated above. Any additions or corrections to the square footage for this project will require an amendment to the Certificate of Compliance.

As the authorized Natomas Unified School District official, I hereby certify that the requirements of Government Code Section 65995 have been complied with by the above signed applicant.

SIGNATURE: DATE: 8/11/03
TITLE: Michael Morman
Facilities Planning Director

69PV

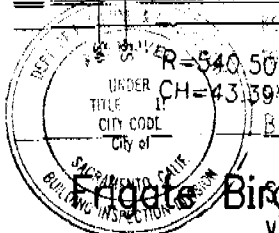
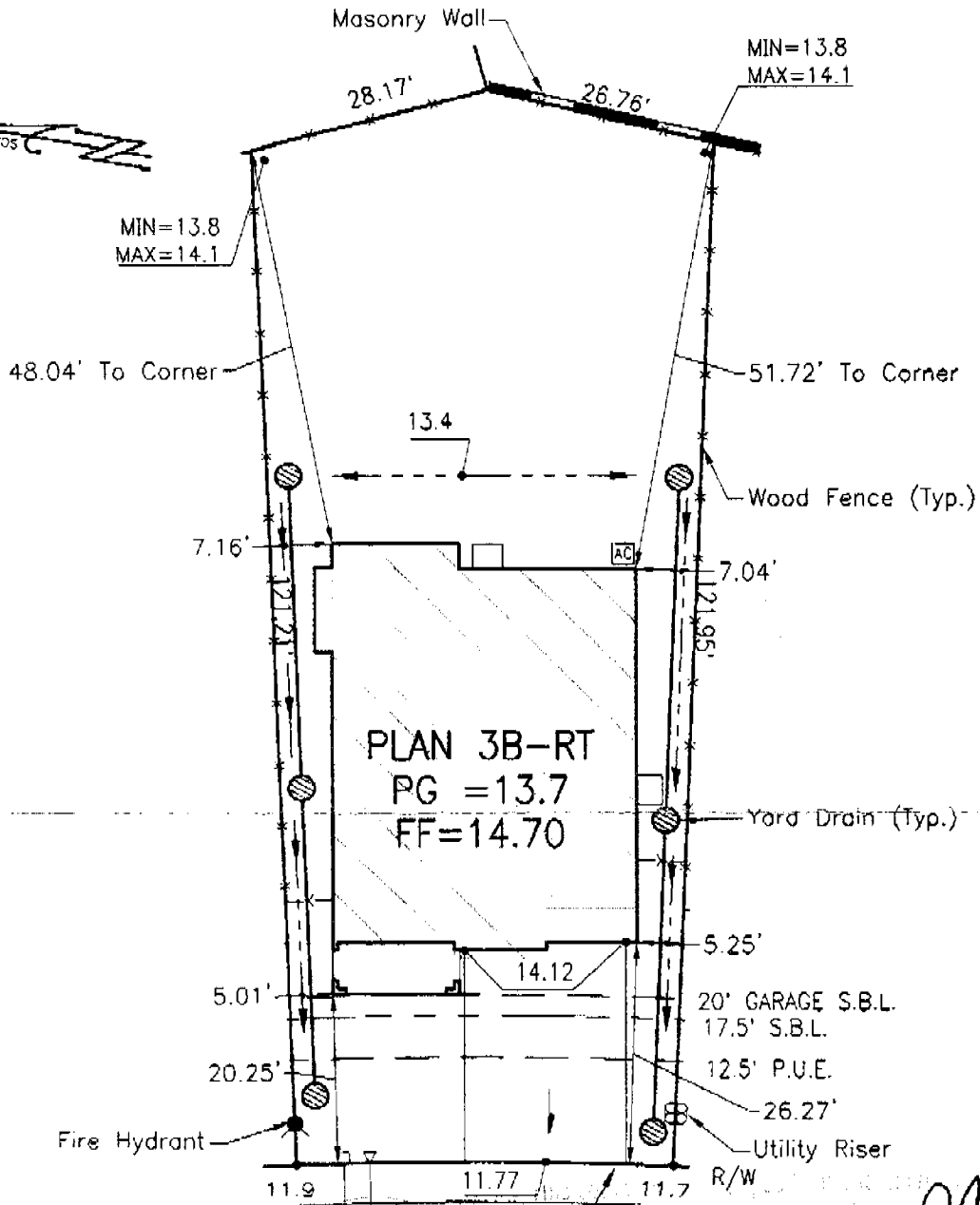

The approval of this plan and specification shall be held to permit or approve the violation of any City Ordinance or State Law.

DIMENSIONS SHOWN ARE APPROXIMATE, EXCEPT FOR MINIMUMS REQUIRED BY ORDINANCE. THIS PLOT DOES NOT REFLECT AS-BUILT CONDITIONS WHICH MAY VARY FROM THIS PLAN.

IBW ENGINEERING
IBW SURVEYING
 PLANNING
BAKER-WILLIAMS ENGINEERING GROUP
 6020 Rutland Drive, Suite 19 (916) 331-4336
 Carmichael, California 95608 (Fax) 331-4430

Parkview Village 7
 by Ryland Homes Inc.
PLOT PLAN FOR LOT 69
 Address: 2868 Frigate Bird Drive
 City of Sacramento, Sacramento Co. Lot Area: 6035.81 s.f.
 Lot Coverage: 27.0%

SCALE : 1"=20'
 Date: May 28, 2003
 Revised: July 18, 03
 Drawn By: SAK
 Job No.: 02-08-093



**F. RODGERS INSULATION
RESIDENTIAL, INC.**
THERMAL INSULATION CONTRACTORS
Residential

8256

7775 LAS POSITAS ROAD · LIVERMORE, CA 94551
(925) 294-9400 · FAX (925) 294-9475

1300 S RIVER RD. #125 · W. SACRAMENTO, CA 95691
(916) 386-9400 · FAX (916) 386-9446



Parcel # 69 LOT # 69 TRACT # POK...

STREET 2868 Frigatebird CITY ...

EXTERIOR WALLS: MANUFACTURER 01c THICKNESS/TYPE ... R- VALUE 13

CEILINGS: BATT: MANUFACTURER 01c THICKNESS/TYPE ... R- VALUE 38

BLOWN IN: MANUFACTURER 01c MINIMUM THICKNESS ... R- VALUE 30

SQUARE FOOTAGE COVERED 1424 NUMBER OF BAGS USED 29

FLOORS & OVERHANGS: MANUFACTURER ... THICKNESS/TYPE ... R- VALUE ...

OTHER: MANUFACTURER ... THICKNESS/TYPE ... R- VALUE ...

GENERAL CONTRACTOR ... CALIFORNIA CONTRACTORS LICENSE # ...

DATE ...

SIGNATURE ... TITLE ...

INSULATION CONTRACTOR F. RODGERS INSULATION RESIDENTIAL
CALIFORNIA CONTRACTORS LICENSE #771285

DATE 12-12-03

SIGNATURE ... TITLE ...

White - Customer Copy Yellow - Invoice Copy Pink - Field Copy Gold - Office Copy

INSTALLATION CARD
(Coating system Trade Name)
(Name of coating manufacturer)

Job Address
2868 Frigatebird Dr.
Lot # 69
0311768

ICBO Evaluation Service, Inc.
Report No. EL-4004

Date of Job Completion 12/1/04

Plastering Contractor
Name: Mid Valley Plastering Inc.
Address: 15300 S. McKinley Ave Lathrop CA 95330
Telephone No. (209) 858-9766
Approved contractor number as
issued by the coating manufacturer 2315

This is to certify that the exterior coating system on the building exterior at the above address has been installed in accordance with the evaluation report specified above and the manufacturer's instructions.



Date

This installation card must be presented to the building inspector after completion of work and before final inspection.

FIGURE 3

