

THIS IS A 2 PART FORM
WRITE ON A FIRM SURFACE

CONSTRUCTION LENDING AGENCY

I hereby affirm under penalty of perjury that there is a construction lending agency for the performance of the work for which this permit is issued. (Sec. 3097, Civ. C.)

Lenders Name _____
Lenders Address _____

LICENSED CONTRACTORS DECLARATION

I hereby affirm under penalty of perjury that I am licensed under provisions of Chapter 9 (commencing with Section 7000) of Division 3 of the Business and Professions Code and my license is in full force and effect.

License Class S-415 Lic. Number 704587
Date 11/29/04 Contractor James R. U... (Signature)

OWNER BUILDER DECLARATION

I hereby affirm under penalty of perjury that I am exempt from the Contractors License Law for the following reason (Sec. 7031.5, Business and Professions Code): Any city or structure, prior to its issuance, also requires the applicant for such permit to file a signed statement that he or she is licensed pursuant to the provisions of the Contractors and Professions Code (Chapter 9 (commencing with Section 7000) of Division 3 of the Business and Professions Code) or that he or she is exempt therefrom and the basis for the alleged exemption. Any violation of Section 7031.5 by any applicant for a permit subjects the applicant to a civil penalty of not more than five hundred dollars (\$500.00):

I, as owner of the property, or my employees with wages as their sole compensation, will do the work, and the structure is not intended or offered for sale (Sec. 7044, Business and Professions Code). The Contractors License Law does not apply to an owner of property who builds thereon, and who does such work himself or herself or through his or her own employees, provided that such improvement is sold within one year of completion, the owner-builder will have the burden of proving that he or she did not build JAN 1986 for the purpose of sale.

I, as owner of the property, am NOT exempt from the Contractors License Law to construct the project (Sec. 7044, Business and Professions Code): The Contractors License Law does not apply to an owner of property who builds or improves thereon, and who contracts for such projects with a contractor(s) licensed pursuant to the Contractors License Law).

I am exempt under Sec. _____ B & P C for this reason _____
Date _____ Owner _____

In issuing this building permit, the applicant represents, and the City relies on the representation of the applicant, that the applicant verified all measurements and locations shown on the application or accompanying drawings and that the improvement to be constructed does not violate any law or private agreement relating to permissible or prohibited locations for such improvements. This building permit does not authorize any illegal location of any improvement or the violation of any private agreement relating to location of improvements.

I certify that I have read this application and state that all information is correct. I agree to comply with all city and county ordinances and state laws relating to building construction and hereby authorize representative of this city to enter upon the abovementioned property for inspection purposes.

11/29/04 Date
James R. U... Signature of Applicant or Agent

USE BLACK INK BALL POINT PEN - PRESS FIRMLY
SIGN PERMIT APPLICATION

SITE ADDRESS 2101 S Street SUITE _____ INSP. AREA _____
ASSESSOR PARCEL NO. 010-2033-23 PERMIT NO. 0500573

LICENSED CONTRACTOR NAME OF APPLICANT Pro-Ad Sign Co ADDRESS Rocklin, Ca ZIP CODE _____ PHONE NO. _____
BUSINESS OWNER Rocklin, Ca 05765 916-435100

SIGN INFORMATION

- ATTACHED INTERIOR/ELECT. SINGLE FACED
- UNILLUMINATED NON-ILLUMINATED BILLBOARD/SUBDIVISION
- INDIVIDUAL LETTERS PAINTED ON BUILDING LOGO
- METAL POLE DOUBLE FACED
- PLASTIC MONUMENT VINYL/GATOR FOAM
- WOODEN PROJECTING RE-FACE

SIGN COPY _____

Rite Aid

(A) HEIGHT 24" (B) LENGTH 15'6"
(A X B) SIGN AREA 250 SIGN SIZE N/A
POLE SIZE N/A FOOTING SIZE N/A
STREET FRONTAGE (FT) 97.8
OCCUPANCY FRONTAGE (FT) 97.8

ENGINEERING REQUIRED? YES NO APPROVED BY _____
DESIGN REVIEW REQUIRED? YES NO APPROVED BY _____
SPECIAL PERMIT REQUIRED? YES NO _____
VARIANCE REQUIRED? YES NO _____
LOCATED IN PUD? YES NO WHICH PUD? _____

OFFICE USE ONLY

SIGN VALUATION

A. TYPE OF SIGN LED + neon dual SQ. FT. = \$ _____
B. \$ _____ PER SQ. FT. X SQ. FT. = \$ _____
APPROVED BY mgj DATE 11/30
DENIED BY _____ DATE _____

FINAL INSPECTIONS

BUILDING INSPECTOR _____ DATE _____
ELECTRICAL INSPECTOR 5-9-06 mjs DATE _____
SIGN INSPECTOR _____ DATE _____

FEES: RECEIVED DATE AMOUNT
SIGN APPLICATION FEE _____
SIGN PERMIT FEE _____
ELECTRICAL SIGN FEE _____
CITY BUSINESS LICENSE _____
OTHER _____

TOTAL FEES \$ 333.51

THIS PERMIT SHALL EXPIRE BY LIMITATION IF WORK AUTHORIZED IS NOT COMMENCED WITHIN 180 DAYS.

505 2011 PERMIT SERVICES 264-7619
CITY OF SACRAMENTO
BUILDING INSPECTION DIVISION
WORKER'S COMPENSATION DECLARATION

I hereby affirm under penalty of perjury one of the following declarations:

I have and will maintain a certificate of consent to self-insure for workers' compensation as provided for by Section 3700 of the Labor Code, for the performance of work for which the permit is issued.

I have and will maintain workers' compensation insurance, as required by Section 3700 of the Labor Code, for the performance of the work for which this permit is issued. My workers' compensation insurance carrier and policy number are:
State fund
17108082-03

Carrier _____
Policy Number _____

(This section need not be completed if the permit is for one hundred dollars (\$100) or less) I certify that in the performance of the work for which this permit is issued, I shall not employ any person in any manner so as to become subject to the workers' compensation laws of California and agree that if I should become subject to the workers' compensation provisions of Section 3700 of the Labor Code, I shall forthwith comply with those provisions.
Date: 11/29/04 Applicant James R. U... (Signature)

WARNING: FAILURE TO SECURE WORKERS' COMPENSATION COVERAGE IS UNLAWFUL AND SHALL SUBJECT AN EMPLOYER TO CRIMINAL PENALTIES AND CIVIL FINES UP TO ONE HUNDRED THOUSAND DOLLARS (\$100,000) IN ADDITION TO THE COST OF COMPENSATION, DAMAGES AS PROVIDED FOR IN SECTION 3706 OF THE LABOR CODE, INTEREST AND ATTORNEY'S FEES.

OFFICE COPY THIS IS A 2 PART FORM
WRITE ON A FIRM SURFACE

CONSTRUCTION LENDING AGENCY

I hereby affirm under penalty of perjury that there is a construction lending agency for the performance of the work for which this permit is issued (Sec. 3097, Civ.C).

Lenders Name _____

Lenders Address _____

LICENSED CONTRACTORS DECLARATION

I hereby affirm under penalty of perjury that I am licensed under provisions of Chapter 9 (commencing with Section 7000) of Division 3 of the Business and Professions Code and my licensing is in full force and effect.

License Class C-45 Lic. Number 704587

Date 11/29/04 Contractor Jawell K. U...

OWNER/BUILDER DECLARATION

I hereby affirm under penalty of perjury that I am exempt from the Contractors License Law for the following reason (Sec. 7031.5, Business and Professions Code: Any city or county which requires a permit to construct, alter, improve, demolish, or repair any structure, prior to its issuance, also requires the applicant for such permit to file a signed statement that he or she is licensed pursuant to the provisions of the Contractors License Law (Chapter 9 (commencing with Section 7000) of Division 3 of the Business and Professions Code) or that he or she is exempt therefrom and the basis for the alleged exemption. Any violation of Section 7031.5 by any applicant for a permit subjects the applicant to a civil penalty of not more than five hundred dollars (\$500.00):

I, as owner of the property, or my employees with wages as their sole compensation, will do the work, and the structure is not intended or offered for sale (Sec. 7044, Business and Professions Code: The Contractors License Law does not apply to an owner of property who builds or improves thereon, and who does such work himself or herself or through his or her own employees, provided that such improvements are not intended or offered for sale. If, however, the building or improvement is sold within one year of completion, the owner-builder will have the burden of proving that he or she did not build for the purpose of sale.)

I, as owner of the property, am exempt from the Contractors License Law for the following reason (Sec. 7044, Business and Professions Code: The Contractors License Law does not apply to an owner of property who builds or improves thereon, and who contracts for such projects with a contractor licensed pursuant to the Contractors License Law).

I am exempt under Sec. _____ B & P C for this reason _____

Date _____ Owner _____ (Signature)

In issuing this building permit, the applicant represents, and the City relies on the representation of the applicant, that the applicant verified all measurements and locations shown on the application or accompanying drawings and that the improvement to be constructed does not violate any law or private agreement relating to permissible or prohibited locations for such improvements. This building permit does not authorize any illegal location of any improvement or the violation of any private agreement relating to location of improvements.

I certify that I have read this application and state that all information is correct. I agree to comply with all city and county ordinances and state laws relating to building construction and hereby authorize representative of this city to enter upon the abovementioned property for inspection purposes.

11/29/04 Date Jawell K. U... Signature of Applicant or Agent

USE BLACK INK BALL POINT PEN — PRESS FIRMLY
SIGN PERMIT APPLICATION

SUITE _____

INSP. AREA _____

SITE ADDRESS 2101 S St.

ASSESSOR PARCEL NO. _____

PERMIT NO. _____

NAME OF APPLICANT _____

ADDRESS _____

PHONE NO. _____

LICENSED CONTRACTOR PRO-ACI

Rocklin, Ca

ZIP CODE 95765

PHONE NO. 916 435-1055

ATTACHED INTERIOR/ELECT. SINGLE FACED BILLBOARD/SUBDIVISION

ILLUMINATED NON-ILLUMINATED PAINTED ON BUILDING LOGO

INDIVIDUAL LETTERS POLE DOUBLE FACED

METAL MONUMENT VINYL/GATOR FOAM

WOODEN PROJECTING RE-FACE

SIGN INFORMATION

(A) HEIGHT 29' (B) LENGTH 19'6"

(A X B) SIGN AREA 561 SQ. FT. 21.05

POLE SIZE N/A FOOTING SIZE N/A

STREET FRONTAGE (FT) 77'8"

OCCUPANCY FRONTAGE (FT) 77'8"

SIGN COPY BITE AID

OFFICE USE ONLY

ENGINEERING REQUIRED? YES NO APPROVED BY _____

DESIGN REVIEW REQUIRED? YES NO APPROVED BY _____

SPECIAL PERMIT REQUIRED? YES NO # _____

VARIANCE REQUIRED? YES NO # _____

LOCATED IN PUD? YES NO WHICH PUD? _____

SIGN VALUATION

A. TYPE OF SIGN _____

B. \$ _____ PER SQ. FT. X SQ. FT. = \$ _____

APPROVED BY [Signature] DATE 11/29/04

DENIED BY _____ DATE _____

FINAL INSPECTIONS

BUILDING INSPECTOR _____ DATE _____

ELECTRICAL INSPECTOR _____ DATE _____

SIGN INSPECTOR _____ DATE _____

FEES: RECEIVED AMOUNT

DATE _____

SIGN APPLICATION FEE _____

SIGN PERMIT FEE _____

ELECTRICAL SIGN FEE _____

CITY BUSINESS LICENSE _____

OTHER _____

TOTAL FEES \$ _____

THIS PERMIT SHALL EXPIRE BY LIMITATION IF WORK AUTHORIZED IS NOT COMMENCED WITHIN 180 DAYS.

THIS IS A 2 PART FORM
WRITE ON A FIRM SURFACE

CONSTRUCTION LENDING AGENCY

I hereby affirm under penalty of perjury that there is a construction lending agency for the performance of the work for which this permit is issued (Sec. 3097, Civ.C).

Lenders Name _____

Lenders Address _____

LICENSED CONTRACTORS DECLARATION

I hereby affirm under penalty of perjury that I am licensed under provisions of Chapter 9 (commencing with Section 7000) of Division 3 of the Business and Professions Code and my license is in full force and effect.

License Class C-49 Lic. Number 704987

Date 11/24/04 Contractor Charles R. Ullrich

OWNER BUILDER DECLARATION

I hereby affirm under penalty of perjury that I am exempt from the Contractors License Law for the following reason (Sec. 7031.5, Business and Professions Code: Any city or county which requires a permit to construct, alter, improve, demolish, or repair any structure, prior to its issuance, also requires the applicant for such permit to file a signed statement that he or she is licensed pursuant to the provisions of the Contractors License Law (Chapter 9 (commencing with Section 7000) of Division 3 of the Business and Professions Code) or that he or she is exempt therefrom, and the basis for the alleged exemption. Any violation of Section 7031.5 by any applicant for a permit subjects the applicant to a civil penalty of not more than five hundred dollars (\$500.00):

I, as owner of the property, or my employees with wages as their sole compensation, will do the work, and the structure is not intended or offered for sale (Sec. 7044, Business and Professions Code). The Contractors License Law does not apply to an owner of property who builds or improves thereon, and who does such work himself or herself or through his or her own employees, provided that such improvements are not intended or offered for sale. If, however, the building or improvement is sold within one year of completion, the owner-builder will have the burden of proving that he or she did not build or improve for the purpose of sale.)

I, as owner of the property, am exclusively contracting with licensed contractors to construct the project (Sec. 7044, Business and Professions Code). The Contractors License Law does not apply to an owner of property who improves thereon, and who contracts for such projects with one or more licensed contractors pursuant to the Contractors License Law.

I am exempt under Sec. _____ B & P C for this reason: NORTH PERMIT CENTER

Date _____ (Signature) _____

In issuing this building permit, the applicant represents, and the City relies on the representation of the applicant, that the applicant verified all measurements and locations shown on the application or accompanying drawings and that the improvement to be constructed does not violate any law or private agreement relating to permissible or prohibited locations for such improvements. This building permit does not authorize any illegal location of any improvement or the violation of any private agreement relating to location of improvements.

I certify that I have read this application and state that all information is correct. I agree to comply with all city and county ordinances and state laws relating to building construction and hereby authorize representatives of this city to enter upon the abovementioned property for inspection purposes.

Date 11/24/04 Signature of Applicant or Agent Charles R. Ullrich

USE BLACK INK BALL POINT PEN — PRESS FIRMLY
SIGN PERMIT APPLICATION

SUITE

SITE ADDRESS

2101 S ST

INSP. AREA

ASSESSOR PARCEL NO.

PERMIT NO.

NAME OF APPLICANT

PRO-ACI Rocklin, CA

ADDRESS

ZIP CODE

PHONE NO.

95765916 925-1088-1088

SIGN INFORMATION

- ATTACHED
- ILLUMINATED
- INDIVIDUAL LETTERS
- METAL
- PLASTIC
- WOODEN
- INTERIOR / ELECT.
- NON-ILLUMINATED
- PAINTED ON BUILDING
- POLE
- MONUMENT
- PROJECTING
- SINGLE FACED
- BILLBOARD / SUBDIVISION
- LOGO
- DOUBLE FACED
- WYNILGATOR FOAM
- RE-FACE

SIGN COPY

primary

(A) HEIGHT 24"

(B) LENGTH 12' 6 1/2"

(A X B) SIGN AREA 25.0825

POLE SIZE N/A FOOTING SIZE N/A

STREET FRONTAGE (FT) 97.8'

OCCUPANCY FRONTAGE (FT) 97.8'

OFFICE USE ONLY

ENGINEERING REQUIRED? YES NO APPROVED BY _____

PERMIT REVIEW REQUIRED? YES NO APPROVED BY _____

SPECIAL PERMIT REQUIRED? YES NO _____

VARIANCE REQUIRED? YES NO _____

LOCATED IN PUD? YES NO WHICH PUD? _____

SIGN VALUATION

A. TYPE OF SIGN _____

B. \$ _____ PER SQ. FT. X _____ SQ. FT. = \$ _____

APPROVED BY [Signature] DATE [Date]

DENIED BY _____ DATE _____

FINAL INSPECTIONS

BUILDING INSPECTOR _____ DATE _____

ELECTRICAL INSPECTOR _____ DATE _____

SIGN INSPECTOR _____ DATE _____

RECEIVED AMOUNT

DATE DATE DATE

SIGN APPLICATION FEE _____

SIGN PERMIT FEE _____

ELECTRICAL SIGN FEE _____

CITY BUSINESS LICENSE _____

OTHER _____

TOTAL \$ _____

THIS PERMIT SHALL EXPIRE BY LIMITATION IF WORK AUTHORIZED IS NOT COMMENCED WITHIN 180 DAYS.

PAID

JAN 1 2005

NORTH PERMIT CENTER

OFFICE COPY THIS IS A 2 PART FORM
WRITE ON A FIRM SURFACE

CONSTRUCTION LENDING AGENCY

I hereby affirm under penalty of perjury that there is a construction lending agency for the performance of the work for which this permit is issued (Sec. 3097, Civ.C).

Lenders Name _____

Lenders Address _____

LICENSED CONTRACTORS DECLARATION

I hereby affirm under penalty of perjury that I am licensed under provisions of Chapter 9 (commencing with Section 7000) of Division 3 of the Business and Professions Code and my license is in full force and effect.

License Class C-45 Lic. Number 7045887

Date 11/29/04 Contractor David R. Jones

(Signature)

OWNER-BUILDER DECLARATION

I hereby affirm under penalty of perjury that I am exempt from the Contractors License Law for the following reason (Sec. 7031.5, Business and Professions Code: Any city or county which requires a permit to construct, alter, improve, demolish, or repair any structure, prior to its issuance, also requires the applicant for such permit to file a signed statement that he or she is licensed pursuant to the provisions of the Contractors License Law (Chapter 9 (commencing with Section 7000) of Division 3 of the Business and Professions Code) or that he or she is exempt therefrom and the basis for the alleged exemption. Any violation of Section 7031.5 by any applicant for a permit subjects the applicant to a civil penalty of not more than five hundred dollars (\$500.00):

I, as owner of the property, or my employees with wages as their sole compensation, will do the work, and the structure is intended or offered for sale (Sec. 7044, Business and Professions Code: The Contractors License Law does not apply to an owner of property who builds or improves, and who does such work himself or herself or through his or her own employees, provided that such improvements are not intended for sale. If, however, the building or improvement is sold within one year of completion, the owner-builder will have the burden of proving that he or she did not build or improve for the purpose of sale.)

I, as owner of the property, am exclusively co-owner licensed contractors to construct the project (Sec. 7044, Business and Professions Code: The Contractors License Law does not apply to an owner of property who builds or improves thereon, and who contracts for such projects with a contractor(s) licensed pursuant to the Contractors License Law).

I am exempt under Sec. _____ B & P C for this reason _____

Date _____

Owner _____

(Signature)

In issuing this building permit, the applicant represents, and the City relies on the representation of the applicant, that the applicant verified all measurements and locations shown on the application or accompanying drawings and that the improvement to be constructed does not violate any law or private agreement relating to permissible or prohibited locations for such improvements. This building permit does not authorize any illegal location of any improvement or the violation of any private agreement relating to location of improvements.

I certify that I have read this application and state that all information is correct. I agree to comply with all city and county ordinances and state laws relating to building construction and hereby authorize representative of this city to enter upon the abovementioned property for inspection purposes.

Date 11/29/04

Signature of Applicant or Agent David R. Jones

USE BLACK INK BALL POINT PEN — PRESS FIRMLY
SIGN PERMIT APPLICATION

SUITE _____

SITE ADDRESS

2101 S St.

INSP. AREA _____

ASSESSOR PARCEL NO. _____

PERMIT NO. _____

NAME OF APPLICANT

Rocklin, CA 95760 916-435-105

PHONE NO. _____

ZIP CODE _____

SIGN INFORMATION

- ATTACHED
- ILLUMINATED
- INDIVIDUAL LETTERS
- METAL
- ELASTIC
- WOODEN
- INTERIOR / ELECT.
- NON-ILLUMINATED
- PAINTED ON BUILDING
- POLE
- MONUMENT
- PROJECTING
- SINGLE FACED
- BILLBOARD / SUBDIVISION
- LOGO
- DOUBLE FACED
- VINYL/GATOR FOAM
- RE-FACE

SIGN COPY _____

1 hr Photo

5050514

CITY OF SACRAMENTO PERMIT SERVICES
BUILDING INSPECTION DIVISION 284-7619

WORKER'S COMPENSATION DECLARATION

I hereby affirm under penalty of perjury one of the following declarations:

I have and will maintain a certificate of consent to self-insure for workers' compensation as provided for by Section 3700 of the Labor Code, for the performance of work for which the permit is issued.

I have and will maintain workers' compensation insurance, as required by Section 3700 of the Labor Code, for the performance of the work for which this permit is issued. My workers' compensation insurance carrier and policy number are:
State Fund
Policy Number 1768982-03

Carrier _____

Policy Number _____

SIGN VALUATION

A. TYPE OF SIGN _____

B. \$ _____ PER SQ. FT. X _____ SQ. FT. = \$ _____

APPROVED BY [Signature] DATE _____

DENIED BY _____ DATE _____

FINAL INSPECTIONS

BUILDING INSPECTOR _____ DATE _____

ELECTRICAL INSPECTOR _____ DATE _____

SIGN INSPECTOR _____ DATE _____

FEES: RECEIVED

DATE AMOUNT

SIGN APPLICATION FEE _____

PERMIT FEE _____

ELECTRICAL SIGN FEE _____

CITY BUSINESS LICENSE _____

OTHER _____

TOTAL \$ _____

THIS PERMIT SHALL EXPIRE BY LIMITATION IF WORK AUTHORIZED IS NOT COMMENCED WITHIN 180 DAYS.

PAID
CITY OF SACRAMENTO
JAN 18 2005
NORTH PERMIT
CENTER

S05 0011
S05 0012
S05 0013
S05 0014

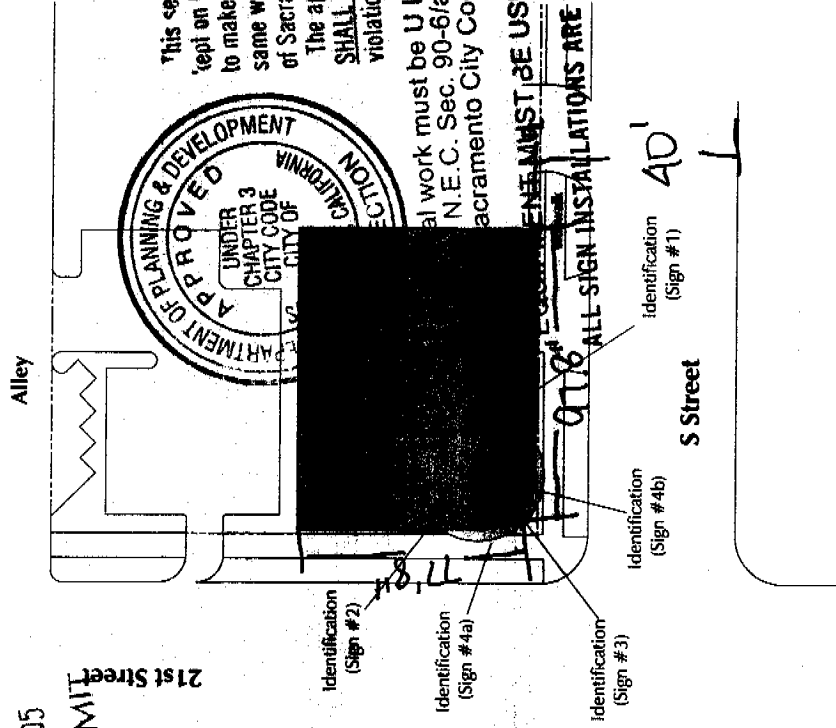

This set of plans and specifications must be kept on the job at all times and it is unlawful to make any changes or alterations from the same without written permission from the City of Sacramento Sign Section.
The approval of this plan and specification SHALL NOT be held to permit or approve the violation of any City Ordinance or State Law.
All work must be U.L. labeled or be of equivalent N.E.C. Sec. 90-6/and comply with chapter 14, Sacramento City Code.

ALL SIGN INSTALLATIONS ARE SUBJECT TO FIELD INSPECTIONS

Corner Elevation

Scale : 1" = 60'

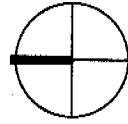

CITY COPY

Rite Aid #6457 — 2101 S Street, Sacramento, CA

Lead #CC-484309

This is an original unpublished drawing, submitted for your use in connection with a project being planned for you by SignArt. It is not to be reproduced, copied or exhibited in any fashion without written permission of SignArt.

©2004 CA,ra6457

AR 10-13-04 11-8-04

Approved for: _____
By: _____
Date: _____

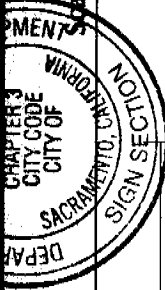
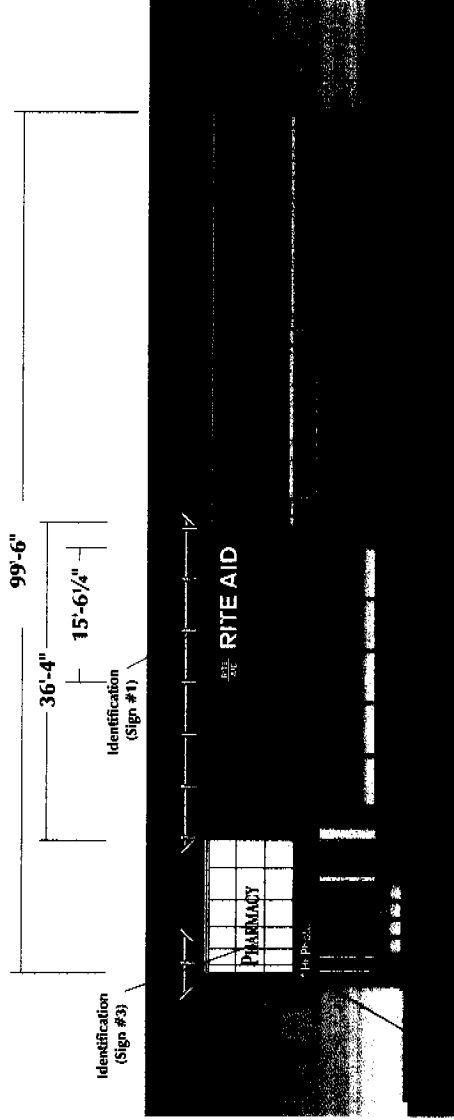

and specifications must be all times and it is unlawful to make any changes or alterations from the same without written permission from the City of Sacramento, Sign Section. The approval of this plan and specification SHALL NOT be held to permit or approve the violation of any City Ordinance or State Law.

South Elevation

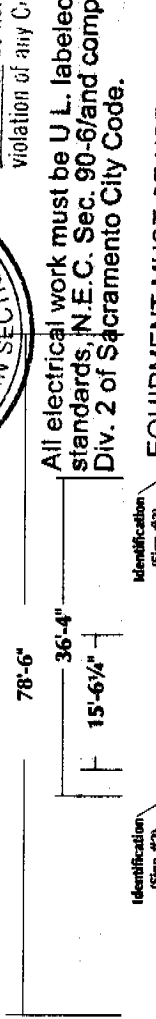

West Elevation

Equipment must be used as design intended. Signs are subject to field inspections.

All electrical work must be U.L. labeled or be of equivalent standards, N.E.C. Sec. 90-6 and comply with chapter 14, Div. 2 of Sacramento City Code.

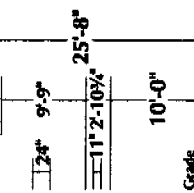
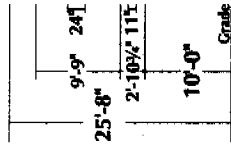

West Elevation

Scale : 3/64" = 1'-0"

Rite Aid #6457 — 2101 S Street, Sacramento, CA

Lead #GC-484309

This is an original unpublished drawing, submitted for your use in connection with a project being planned for you by SignArt. It is not to be reproduced, copied or exhibited in any fashion without written permission of SignArt.

AR 12-13-04 12-28-04 12-17-04 12-28-04

©2004 CA,ra6457

12-29-04 Approved for:

By: Date:

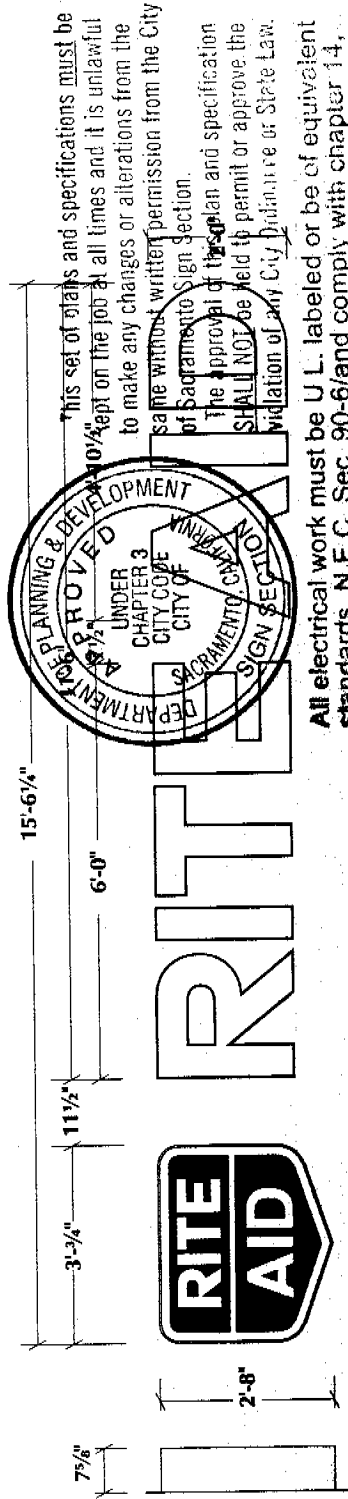

This set of plans and specifications must be kept on the job at all times and it is unlawful to make any changes or alterations from the same without written permission from the City of Sacramento Sign Section. The approval of this plan and specification SHALL NOT be held to permit or approve the violation of any City Ordinance or State Law.

All electrical work must be U.L. labeled or be of equivalent standards, N.E.C. Sec. 90-6 and comply with chapter 14, Div. 2 of Sacramento City Code.

Scale: 1/4" = 1'-0"
 Square Footage
 2'-0" x 3'-3/4" = 8.17 Sq. Ft.
 2'-0" x 3'-3/4" = 8.17 Sq. Ft.
 Total = 31.17 Sq. Ft.

Identification (Signs #1 & #2) Primary Wall Signs

Shield Logo — SGC-410 flat, .155 white Lexan Faced, U.L. labeled, aluminum logo can with 7/4" returns and 1/4" retainer ring painted GripCard semi-gloss white. Shield panels to be overlaid with Calon #2283 red and #2870 blue pressure sensitive vinyl. **EQUIPMENT MUST BE USED AS DESIGNED IN THESE PLANS**
 on shield to be weeded out to appear white. Shield to be illuminated with daylight H.O. fluorescent lamps powered by 120 volt transformer electronic ballast.

'RITE AID' Letters — SGC-410 flat, .155 white Lexan Faced, U.L. labeled, aluminum channel letters with 7/4" Deep returns and 1/4" retainers to be painted GripCard semi-gloss to match Calon II #2870 blue vinyl. Insides of letters to be painted with AZKO bright white reflective finish. Letters are illuminated with 2 stokes of 15mm, ECL Designer 65 tri-phosphor white neon powered by 60 m.a., 120 volt transformers.

Identification (Sign #3)

Primary Reverse Illuminated Channel Letters

Pharmacy Letters — Custom fabricated 2" deep reverse channel letters with .100 aluminum faces and welded .080 aluminum returns painted GripCard semi-gloss to match Calon II #2870 blue pressure sensitive vinyl. Insides of letters to be painted with AZKO bright white reflective finish. Letters are silhouette lit using Hyperion white R-Lite LED system powered by 6 volt A.C. power supply and have flat SGC-100 clear Lexan "bird shield" backs overlaid with 3M #3635-70 diffuser vinyl.

Note: Reverse channel letters are to be double nitted to and stud mounted 1/8" from radius facade.

Scale: 3/8" = 1'-0"
 Square Footage
 24.00" x 1'-6 1/2" = 3.08 Sq. Ft.
 PHARMACY 18.00" x 11'-1" = 16.63 Sq. Ft.
 Total = 19.71 Sq. Ft.

Rite Aid #6457 — 2101 S Street, Sacramento, CA

Lead #GC-484309

This is an original unpublished drawing, submitted for your use in connection with a project being planned for you by SignArt. It is not to be reproduced, copied or exhibited in any fashion without written permission of SignArt.

AR 10-13-04

11-8-04

Approved for:

By:

Date:

©2004

CA,ra6457

- 1 .050 Aluminum letter sides painted #2870 blue vinyl.
- 2 1" x 1/2" Aluminum angle retainers painted CripCard semi-gloss to match Calon II #2870 blue vinyl with #8 x 1/2" hex head screws as needed.
- 3 Flat SC-410 white Lexan face.
- 4 15mm, ECL Designer 6500 white neon tubing.
- 5 Two 1/4" weep holes at low points of letters with screen covering siliconed in place.
- 6 .063 Aluminum letter back.
- 7 Note: Letter sides and backs siliconed together and continuously siliconed.
- 8 3/8" Aluminum insert nut.
- 9 1/2" Aluminum threaded rod with washer and nuts as needed. Exact fastener to vary with different facade/building construction.
- 9 Neon tube support brackets. (as needed)

- 10 Building facade, BRM construction to be siliconed.
- 11 Building facade, BRM construction to be siliconed.
- 12 Building facade, BRM construction to be siliconed.
- 13 Building facade, BRM construction to be siliconed.
- 14 Building facade, BRM construction to be siliconed.
- 15 Building facade, BRM construction to be siliconed.
- 16 Building facade, BRM construction to be siliconed.

- 17 Building facade, BRM construction to be siliconed.
- 18 Building facade, BRM construction to be siliconed.
- 19 Building facade, BRM construction to be siliconed.
- 20 Building facade, BRM construction to be siliconed.
- 21 Building facade, BRM construction to be siliconed.
- 22 Building facade, BRM construction to be siliconed.

- 23 Building facade, BRM construction to be siliconed.
- 24 Building facade, BRM construction to be siliconed.
- 25 Building facade, BRM construction to be siliconed.
- 26 Building facade, BRM construction to be siliconed.
- 27 Building facade, BRM construction to be siliconed.
- 28 Building facade, BRM construction to be siliconed.

- 29 Building facade, BRM construction to be siliconed.
- 30 Building facade, BRM construction to be siliconed.
- 31 Building facade, BRM construction to be siliconed.
- 32 Building facade, BRM construction to be siliconed.
- 33 Building facade, BRM construction to be siliconed.
- 34 Building facade, BRM construction to be siliconed.

Scale: 3" = 1'-0"

Approved for: _____ Date: _____

By: _____

EQUIPMENT MUST BE USED AS DESIGN INTENDED
ALL SIGN INSTALLATIONS ARE SUBJECT TO FIELD INSPECTIONS.

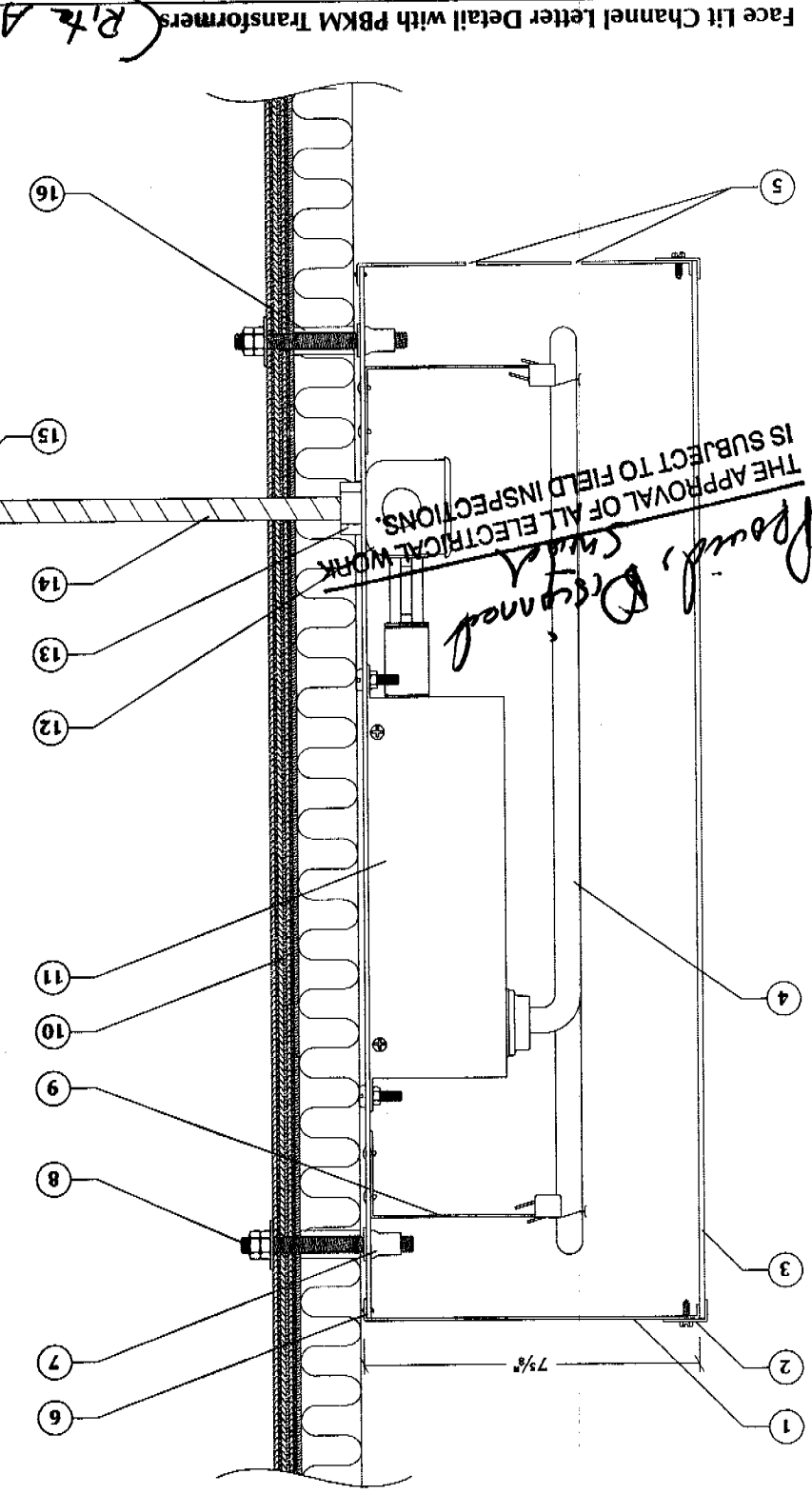

This is an original unpublished drawing, submitted for your use in connection with a project being planned for you by SignArt. It is not to be reproduced, copied or exhibited in any fashion without written permission of SignArt. © 2004 LetterDetail

Rite Aid World and Retro-Fit RA-1 Stores

MC 9-22-04 6-15-04 Approved for: _____ Date: _____

By: _____

Reverse Lit Pharmacy Channel Letter Detail

Scale: 3" = 1'-0"

ALL ELECTRICAL WORK MUST BE U.L. LABELLED AND CONFORM TO THE NATIONAL ELECTRICAL CODE. ALL SIGN INSTALLATIONS ARE SUBJECT TO THE APPROVAL OF ALL ELECTRICAL WORK IS SUBJECT TO FIELD INSPECTIONS

Provide Discussed

ALL EQUIPMENT MUST BE USED AS SPECIFIED IN THE U.L. LABELING AND CONFORM TO THE NATIONAL ELECTRICAL CODE. ALL SIGN INSTALLATIONS ARE SUBJECT TO THE APPROVAL OF ALL ELECTRICAL WORK IS SUBJECT TO FIELD INSPECTIONS

DMV 2 of Sacramento City Code. Sec. 90-67 and 90-68 shall apply to all sign installations. The approval of this plan and specifications for same shall be held to permit operations from the Department of Public Works and Engineering, City of Sacramento. Violation of any City Ordinance shall be cause for the suspension of the permit and the contractor shall be held liable for all costs incurred by the City of Sacramento. This set of plans and specifications must be kept on the job at all times and it is unlawful to make any changes or alterations from the same without written permission from the City of Sacramento. The approval of this plan and specifications for same shall be held to permit operations from the Department of Public Works and Engineering, City of Sacramento. Violation of any City Ordinance shall be cause for the suspension of the permit and the contractor shall be held liable for all costs incurred by the City of Sacramento.

- 1 .080 Aluminum letter side.
- 2 Spot welds as needed.
- 3 .100 Aluminum face.
- 4 Hyperion R-Lite white LED system (gathered to 1" O.C.).
- 5 .155 SGC-100 Clear Lexan bird shield.
- 6 Aluminum clips (90° bends) blind riveted to Lexan bird shields and screwed to letter sides with #6 x 1/2" blue s.m. stainless steel fasteners.
- 7 3/8" x 3" flat head bolts with washers, nuts, and Lok-nuts as needed.
- 8 1/4" x 18 gauge #6061-T6 Aluminum tube spacer.
- 9 2" x 4" Vertical steel studs (verify).
- 10 3mm painted Alucobond facade.
- 11 1/2" Chase nipple.
- 12 1/2" Aluminum electrical coupling.
- 13 1/2" lightweight non-metallic flexible conduit.
- 14 15' x 15' x 15' LED power supplies (120 volt).
- 15 15' x 15' x 15' LED power supplies (120 volt).

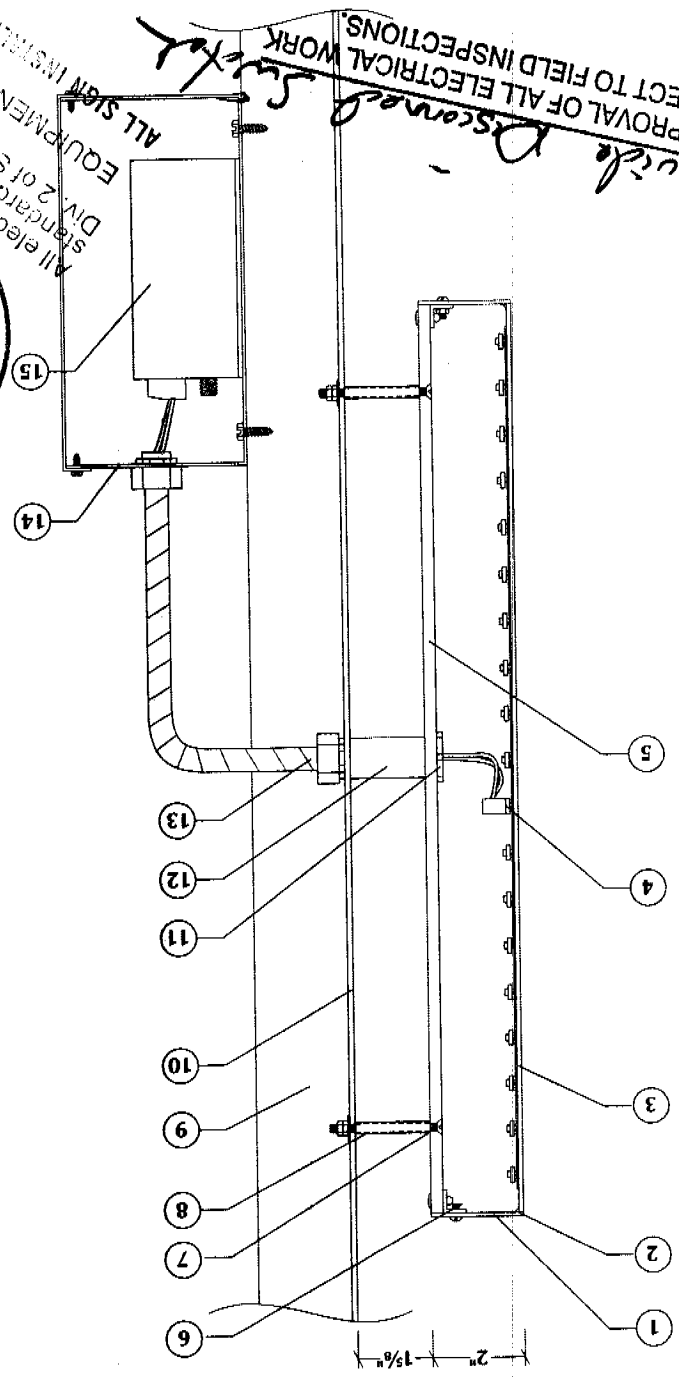

SignArt

Secondary Illuminated Channel Letters

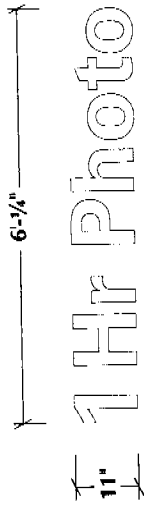

Identification (Sign #4)

Secondary Illuminated Channel Letters

Scale: 3/8" = 1'-0"

Square Footage
1Hr Photo 11' x 6-3/4" = 5.52 Sq.Ft.

Flat SCC-410 white Lexan faced, U.L. labeled, aluminum channel letters with 1" blue jewelite and 2 1/8" aluminum returns painted GripCard semi-gloss to match Calon II #2870 blue vinyl. Insides of letters to be painted with AZKO bright white reflective finish. Letters to be illuminated using Hyperion white R-Lite LED system powered by 6 volt A.C. power supply powered by 120 volt circuit located behind facade. Access to back side of facade by others.

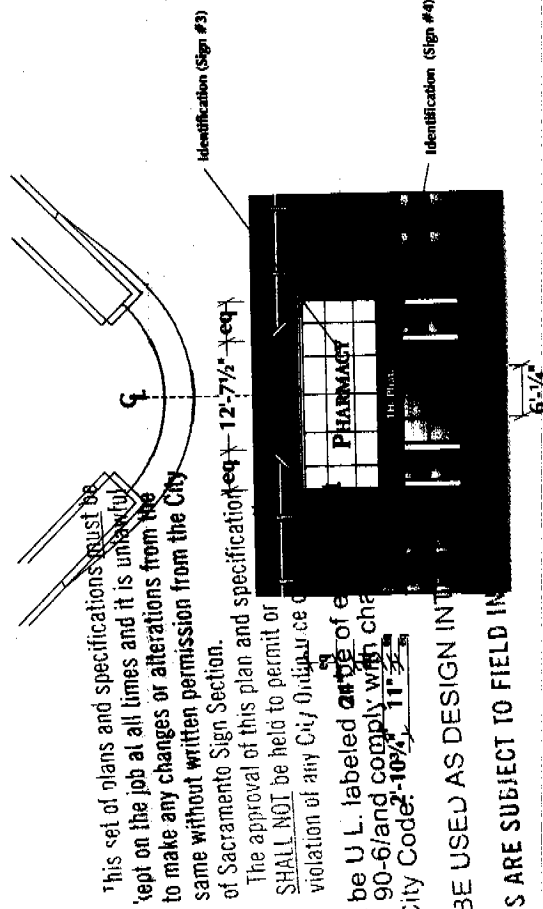
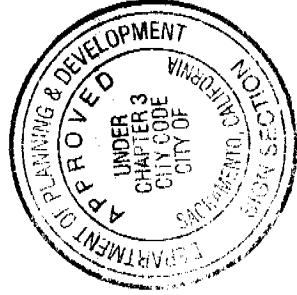

This set of plans and specifications must be kept on the job at all times and it is understood to make any changes or alterations from the same without written permission from the City of Sacramento Sign Section.

The approval of this plan and specification shall NOT be held to permit or violation of any City Ordinance or standards, N.E.C. Sec. 90-6/and comply with chapter 2 of Sacramento City Code.

EQUIPMENT MUST BE USED AS DESIGN INTENT. ALL SIGN INSTALLATIONS ARE SUBJECT TO FIELD INSPECTION.

Scale: 3/64" = 1'-0" Corner Elevation

Rite Aid #6457 — 2101 S Street, Sacramento, CA

Lead #GC-484309
©2004 CA/ra6457

This is an original unpublished drawing, submitted for your use in connection with a project being planned for you by SignArt. It is not to be reproduced, copied or exhibited in any fashion without written permission of SignArt.

AR 12-29-04 Approved for: _____
10-13-04 12:29:04
12-13-04 12:29:04

By: _____ Date: _____

Rite Aid World Sign Package

MC 6-15-04 9-22-04

Approved for:

By:

Date:

This is an original unpublished drawing, submitted for your use in connection with a project being planned for you by SignArt. It is not to be reproduced, copied or exhibited in any fashion without written permission of SignArt. © 2004 LetterDetail

Scale: 3" = 1'-0"

Decor Band Letter Detail

- 1 .050 Aluminum letter sides painted GripCard semi-gloss blue to match Calon II #2870 blue vinyl. Interior of letters sides to be painted with AKZO bright white reflective finish or is to have 3M #3635-100 white light enhancement film pre-applied.
- 2 3/4" blue Jewelrite with #8 x 1/2" Hex head screws every 20" or as needed.
- 3 Flat SC-410 Lexan face.
- 4 Two 1/4" weep holes at low points of letters with screen covering silicone in place.
- 5 .063 Aluminum letter back.
Note: Letter sides and backs stitched together and continuously silicone.
- 6 Hyperton white R-Lite LED system (gathered to 1" spacing)
Low voltage (6 volts) raceway mounted LED power supplies (120 volt circuit required).
- 7 #10 x 1/4" white "Jet Screws" (3-5 per letter).
- 8 6mm Alucabond faced accent band (access panel centered below each attribute letter set).
- 9 Removable panel for access to electric.
- 10 4" x 8" x 18" JIC box.
- 11 3/8" Greenfield aluminum conduit with "twist-in" connectors at letter end and 90° "twist-in" connectors to power supply.
Note: 120 Volt circuit (1.2 amps) with bond wire in 3/8" flexible conduit to area behind decor band centered behind sign position (by others).
- 12 Note: Exact construction of decor band to be verified.

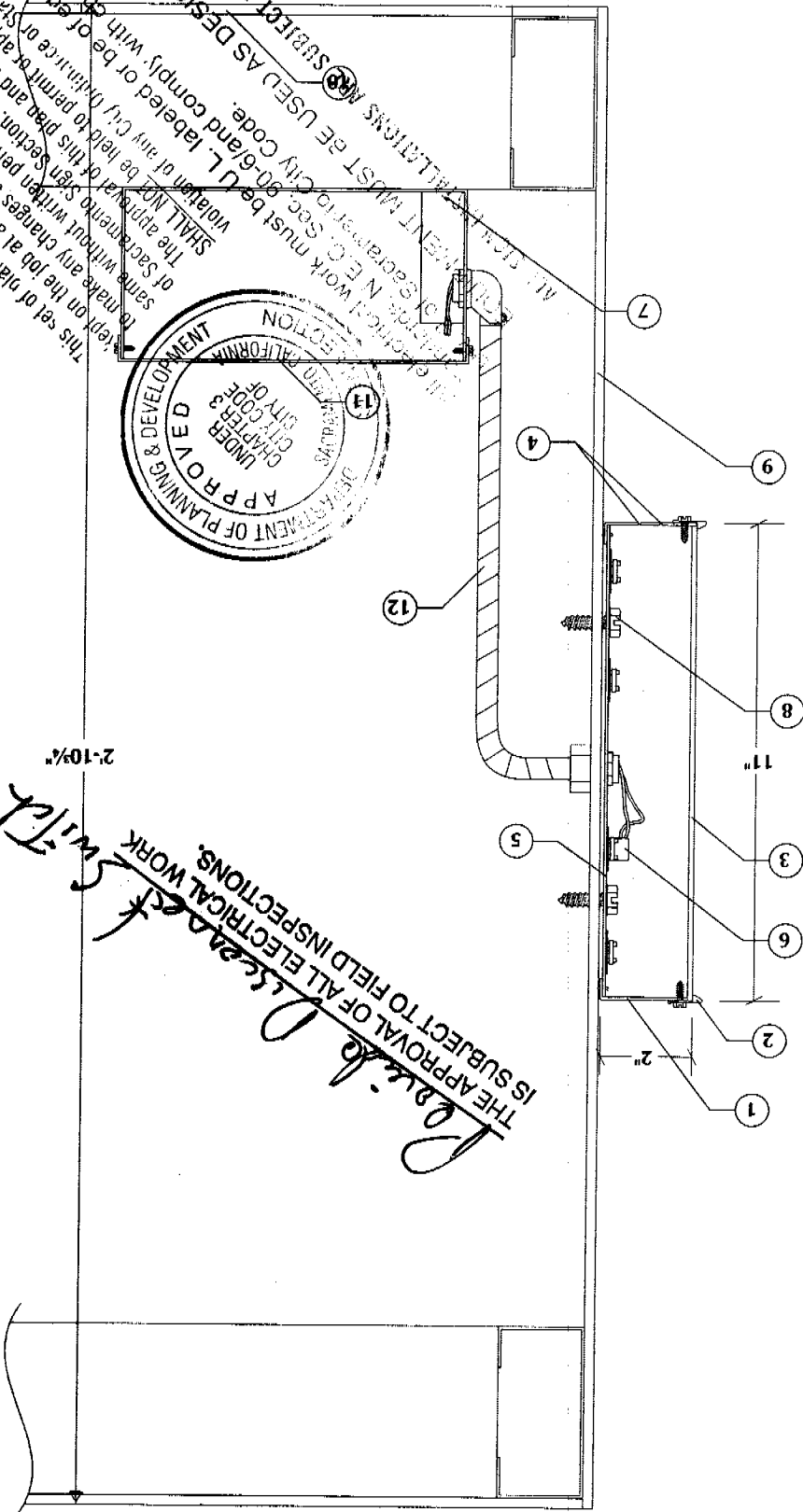

ALL ELECTRICAL WORK MUST BE USED AS DESIGN INTENTIONS
 SUBJECT TO FIELD INSPECTIONS
 THIS SET OF PLANS AND SPECIFICATIONS MUST BE
 APPROVED BY THE CITY OF SACRAMENTO
 DEPARTMENT OF PLANNING & DEVELOPMENT
 CHAPTER 3
 CITY CODE
 UNDER THE PROVISIONS OF
 THE ELECTRICAL WORK MUST BE USED AS DESIGN INTENTIONS
 SUBJECT TO FIELD INSPECTIONS
 SHALL NOT BE HELD RESPONSIBLE FOR ANY VIOLATION OF ANY CITY ORDINANCE OR STATE LAW.
 THE APPROVAL OF ALL ELECTRICAL WORK IS SUBJECT TO FIELD INSPECTIONS.
 Paul P. Leandret
 2-10%