

CITY OF SACRAMENTO  
1231 I Street, Sacramento, CA 95814

Permit No: 0011040  
Insp Area: 4

Site Address: 2061 MOONSTONE WY SAC  
Parcel No: 225-1410-040  
N

NORTHPOINTE PARK UNIT 7-2 LOT 40

Sub-Type: NSFR  
Housing (Y/N):

CONTRACTOR  
CENTEX HOMES  
3300 DOUGLAS BLVD  
STF. 210 95661

OWNER

ARCHITECT

Nature of Work: NSFR MP1922 OPT 10 RMS 2 STORY

CONSTRUCTION LENDING AGENCY : I hereby affirm under penalty of perjury that there is a construction lending agency for the performance of the work for which this permit is issued (Sec. 3097, Civ. C).

Lender's Name N/A Lender's Address \_\_\_\_\_

LICENSED CONTRACTORS DECLARATION: I hereby affirm under penalty of perjury that I am licensed under provisions of Chapter 9 (commencing with section 7000) of Division 3 of the Business and Professions Code and my license is in full force and effect.

License Class B License Number 734094 Date 10 5 00 Contractor Signature Debbie Stowers

OWNER-BUILDER DECLARATION: I hereby affirm under penalty of perjury that I am exempt from the contractors License Law for the following reason (Sec. 7031.5, Business and Professions Code; any city or county which requires a permit to construct, alter, improve, demolish, or repair any structure, prior to its issuance, also requires the applicant for such permit to file a signed statement that he or she is licensed pursuant to the provisions of the Contractors License Law (Chapter 9 (commencing with Section 7000) of Division 8 of the Business and Professions Code) or that he or she is exempt therefrom and the basis for the alleged exemption. Any violation of Section 7031.5 by any applicant for a permit subjects the applicant to a civil penalty of not more than five hundred dollars (\$500.00);

I, as a owner of the property, or my employees with wages as their sole compensation, will do the work, and the structure is not intended or offered for sale (Sec. 7044, Business and Professional Code: The Contractors License Law does not apply to an owner of property who builds or improves thereon, and who does such work himself or herself or through his/her own employees, provided that such improvements are not intended or offered for sale. If, however, the building or improvement is sold within one year of completion, the owner-builder will have the burden of proving that he/she did not build or improve for the purpose of sale.)

I, as owner of the property, am exclusively contracting with licensed contractors to construct the project (Sec. 7044 Business and Professions Code: The Contractors License Law does not apply to an owner of property who builds or improves thereon, and who contracts for such projects with a contractor(s) licensed pursuant to the Contractors License Law).

PAID  
OCT 05 2000  
CITY OF SACRAMENTO  
PERMITS, PLANNING  
& DEVELOPMENT SERVICES

I am exempt under Sec. \_\_\_\_\_ B & PC for this reason: \_\_\_\_\_  
Date \_\_\_\_\_ Owner Signature \_\_\_\_\_

IN ISSUING THIS BUILDING PERMIT, the applicant represents, and the city relies on the representation of the applicant, that the applicant verified all measurements and locations shown on the application or accompanying drawings and that the improvement to be constructed does not violate any law or private agreement relating to permissible or prohibited locations for such improvements. This building permit does not authorize any illegal location of any improvement or the violation of any private agreement relating to location of improvements.

I certify that I have read this application and state that all information is correct. I agree to comply with all city and county ordinances and state laws relating to building construction and hereby authorize representative(s) of this city to enter upon the abovementioned property for inspection purposes.

Date 10 5 00 Applicant/Agent Signature Debbie Stowers

WORKER'S COMPENSATION DECLARATION: I hereby affirm under penalty of perjury one of the following declarations:  
I have and will maintain a certificate of consent to self-insure for workers' compensation as provided for by Section 3700 of the Labor Code, for the performance of work for which the permit is issued

I have and will maintain workers' compensation insurance, as required by Section 3700 of the Labor Code, for the performance of the work for which this permit is issued. My workers' compensation insurance carrier and policy number are:

Carrier AMER. GUAR. & LIAB. INS. Policy Number WC8322096-02 Exp Date 10/01/2000

(This section need not be completed if the permit is for \$100 or less) I certify that in the performance of the work for which this permit is issued, I shall not employ any person in any manner so as to become subject to the workers' compensation laws of California and agree that if I should become subject to the workers' compensation provisions of Section 3700 of the Labor Code, I shall forthwith comply with those provisions.

Date 10 5 00 Applicant Signature Debbie Stowers

WARNING: FAILURE TO SECURE WORKER'S COMPENSATION COVERAGE IS UNLAWFUL AND SHALL SUBJECT AN EMPLOYER TO CRIMINAL PENALTIES AND CIVIL FINES UP TO ONE HUNDRED THOUSAND DOLLARS (\$100,000) IN ADDITION TO THE COST OF COMPENSATION, DAMAGES AS PROVIDED FOR IN SECTION 3706 OF THE LABOR CODE, INTEREST AND ATTORNEY'S FEE.

THIS PERMIT SHALL EXPIRE BY LIMITATION IF WORK IS NOT COMMENCED WITHIN 180 DAYS.

**RESIDENTIAL BUILDING PERMIT APPLICATION**

New Construction

Addition

Remodels

Other

Project Address: 2061 Montrose Avenue

Assessor Parcel # 225-1410-040

**OWNER INFORMATION:**

Lot 40

Legal Property Owner: Center Homes Phone # 786-8693  
 Owner Address: 3700 Douglas Blvd #150 City Roseville State CA Zip 95661

**CONTRACTOR INFORMATION:**

Contractor: Center Homes Lic. # 734094 Phone # 786-8693 Fax# 786-6802

**PROJECT INFORMATION:**

Land Use Zone RIA Occupancy Group R3 Construction Type VN Fed Code 1A  
 No. of stories: 2 No. of rooms: \_\_\_\_\_ Street width: \_\_\_\_\_  
 1<sup>st</sup> Floor Area 1132 2<sup>nd</sup> Floor Area 925 Basement \_\_\_\_\_ Roof Material \_\_\_\_\_

AREA IN SQUARE FOOT OF:	<u>EXISTING</u>	<u>NEW</u>
Dwelling/Living	_____	<u>2063</u>
Garage/Storage	_____	<u>492</u>
Decks/Balconies	_____	_____
Carports	_____	_____

SCOPE OF WORK: MP 1922 New SFR

**FOR OFFICE USE ONLY**

<input type="checkbox"/> Information above complete	<input type="checkbox"/> AR Flood Waiver required	<input type="checkbox"/> Planning Approval
<input type="checkbox"/> Violation files checked	<input type="checkbox"/> Flood Elevation Certificate Required	<input type="checkbox"/> Design Review Approval
<input type="checkbox"/> Standard setbacks	<input type="checkbox"/> Water Development Infill Area	<input type="checkbox"/> Special Fee Districts Apply : _____
<input type="checkbox"/> County Sewer		

**NEW STRUCTURES & ADDITIONS**

❖ THE FOLLOWING MUST BE PROVIDED IN ORDER TO SUBMIT FOR PLAN REVIEW

<input type="checkbox"/> 2 COMPLETE PLANS, LEGIBLE & DRAWN TO SCALE	❖ Plans to include: site plan, floor plan, elevations, roof/ceiling plan, foundation and structural framing details, and structural calculations for non-conforming structures.
<input type="checkbox"/> 3 SETS IF PROJECT IS IN A DESIGN REVIEW AREA	
<input type="checkbox"/> Title 24 Energy Compliance documentation	<input type="checkbox"/> 11" x 17" copy of floor plan for County Assessor
<input type="checkbox"/> Grading and Erosion Control Questionnaire	<input type="checkbox"/> Plan Review Fees

Date: \_\_\_\_\_

Received by: (staff) \_\_\_\_\_

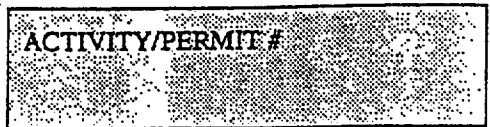

**INSULATION CERTIFICATE**

THIS IS TO CERTIFY THAT INSULATION HAS BEEN INSTALLED IN CONFORMANCE WITH THE CURRENT ENERGY REGULATIONS, CALIFORNIA ADMINISTRATION CODE, TITLE 24, STATE OF CALIFORNIA, IN THE BUILDING LOCATED AT:

SITE ADDRESS: LOT 240 NORTHPOINTE SACRAMENTO, CA  
NUMBER STREET CITY STATE

**CEILINGS:**

BLOW: MANUFACTURER GREENSTONE THICKNESS 10.3" R-VALUE 35  
SQUARE FEET 1139 # BAGS/LBS PER BAGS 38

BATTS: MANUFACTURER JOHNS MANVILLE THICKNESS 13" R-VALUE 38  
JOHNS MANVILLE

**EXTERIOR WALLS:**

MANUFACTURER JOHNS MANVILLE THICKNESS 3.5" R-VALUE 13  
JOHNS MANVILLE 6.5" 19

**FLOOR INSULATION:**

MANUFACTURER JOHNS MANVILLE THICKNESS N/A R-VALUE N/A

**AIR INFILTRATION:** (TITLE 24)  
YES XX NO \_\_\_\_\_

OTHER: \_\_\_\_\_

GENERAL CONTRACTOR: CENTEX HOMES LICENSE # \_\_\_\_\_

BY: \_\_\_\_\_ TITLE \_\_\_\_\_ DATE \_\_\_\_\_

INSULATION CONTRACTOR: WESTERN INSULATION, INC. LICENSE # 481278

BY: Jamie Blair TITLE AUTH. AGENT DATE 2/27/01  
JAMIE BLAIR

Note to Buyer: This plot plan is provided as a general layout of the property. All information on this plan, including but not limited to tree locations and sizes, setback dimensions, driveway grades, and wall heights and locations, are approximate and may vary or change without prior notice.

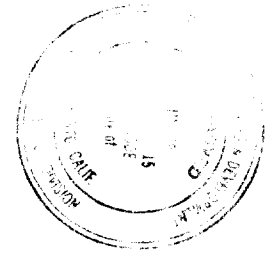
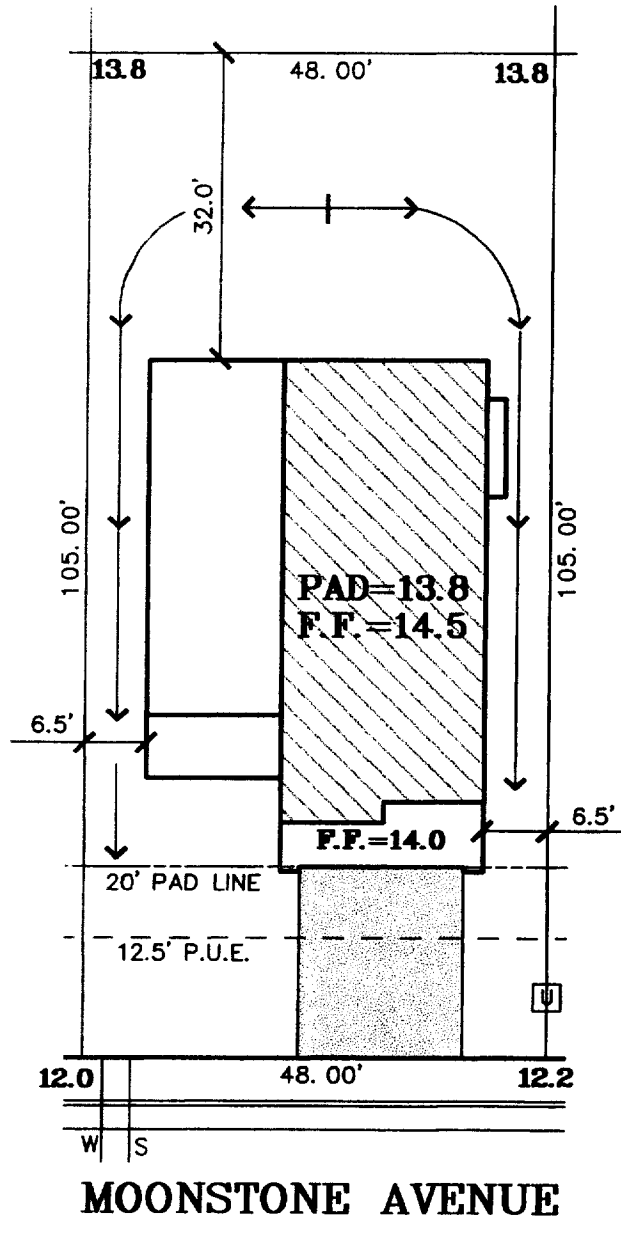

This set of plans and specifications must be kept on the job at all times and it is unlawful to make any changes or alterations from the same without written permission from the Building Inspection Division.  
 The approval of this plan and specification SHALL NOT be held to permit or approve the violation of any City Ordinance or State Law.

**LOT 40**  
**PLAN 1922C RIGHT**  
**A.P.N.:**  
**ADDRESS: 2061 MOONSTONE AVENUE**  
**LOT AREA: 5,040 SF**  
**LOT COVERAGE: 34%**

**READ AND APPROVED**  
 Plan 1922 Land Development A 9/8/00  
 Elevation C Const. Manager \_\_\_\_\_  
 Orientation G-RIGHT Sales Appr. \_\_\_\_\_  
 Color 9 Field Manager \_\_\_\_\_

**The Splink Corporation**  
 2590 VENTURE OAKS WAY  
 SACRAMENTO, CA 95833

**CENTEX HOMES**  
 3700 Douglas Boulevard  
 Suite 150  
 Roseville, Ca. 95661

**NORTHPOINTE PARK**  
**UNIT NO. 7 PHASE 2**  
 City of Sacramento, California

PH:(916)925-5550 FAX:(916)921-9274

office: (916) 786-8693  
 fax: (916) 786-6802

Scale: 1"=20' September 7, 2000