

CITY OF SACRAMENTO
1231 I Street, Sacramento, CA 95814

Permit No: 0001866
Insp Area: 1

Site Address: 5276 L ST SAC
Parcel No: 008-0232-009 5276 1/2

Sub-Type: ASFR
Housing (Y/N): N

CONTRACTOR
PETKUS BROS.
3068 SUNRISE BL
RANCHO CORDOVA CA 95782

OWNER
M CAMBELL
5276 1/2 L ST
SACRAMENTO CA 95819

ARCHITECT

Nature of Work: 200 SQ FT PATIO RM

CONSTRUCTION LENDING AGENCY: I hereby affirm under penalty of perjury that there is a construction lending agency for the performance of the work for which this permit is issued (Sec. 3097, Civ. C).

Lender's Name _____ Lender's Address _____

LICENSED CONTRACTORS DECLARATION: I hereby affirm under penalty of perjury that I am licensed under provisions of Chapter 9 (commencing with section 7000) of Division 3 of the Business and Professions Code and my license is in full force and effect.

X License Class B License Number 670242 Date 2-25-00 Contractor Signature [Signature]

OWNER-BUILDER DECLARATION: I hereby affirm under penalty of perjury that I am exempt from the contractors License Law for the following reason (Sec. 7031.5, Business and Professions Code; any city or county which requires a permit to construct, alter, improve, demolish, or repair any structure, prior to its issuance, also requires the applicant for such permit to file a signed statement that he or she is licensed pursuant to the provisions of the Contractors License Law (Chapter 9 (commencing with Section 7000) of Division 8 of the Business and Professions Code) or that he or she is exempt therefrom and the basis for the alleged exemption. Any violation of Section 7031.5 by any applicant for a permit subjects the applicant to a civil penalty of not more than five hundred dollars (\$500.00);

____ I, as a owner of the property, or my employees with wages as their sole compensation, will do the work, and the structure is not intended or offered for sale (Sec. 7044, Business and Professional Code: The Contractors License Law does not apply to an owner of property who builds or improves thereon, and who does such work himself or herself or through his/her own employees, provided that such improvements are not intended or offered for sale. If, however, the building or improvement is sold within one year of completion, the owner-builder will have the burden of proving that he/she did not build or improve for the purpose of sale.)

____ I, as owner of the property, am exclusively contracting with licensed contractors to construct the project (Sec. 7044, Business and Professions Code: The Contractors License Law does not apply to an owner of property who builds or improves thereon, and who contracts for such projects with a contractor(s) licensed pursuant to the Contractors License Law).

____ I am exempt under Sec. _____ B & PC for this reason: _____

Date _____ Owner Signature _____

IN ISSUING THIS BUILDING PERMIT, the applicant represents, and the city relies on the representation of the applicant, that the applicant verified all measurements and locations shown on the application or accompanying drawings and that the improvement to be constructed does not violate any law or private agreement relating to permissible or prohibited locations for such improvements. This building permit does not authorize any illegal location of any improvement or the violation of any private agreement relating to location of improvements.

I certify that I have read this application and state that all information is correct. I agree to comply with all city and county ordinances and state laws relating to building construction and hereby authorize representative(s) of this city to enter upon the abovementioned property for inspection purposes.

X Date 2-25-00 Applicant/Agent Signature [Signature]

WORKER'S COMPENSATION DECLARATION: I hereby affirm under penalty of perjury one of the following declarations:

____ I have and will maintain a certificate of consent to self-insure for workers' compensation as provided for by Section 3700 of the Labor Code, for the performance of work for which the permit is issued.

____ I have and will maintain workers' compensation insurance, as required by Section 3700 of the Labor Code, for the performance of the work for which this permit is issued. My workers' compensation insurance carrier and policy number are:

Carrier STATE FUND Policy Number 713 U 502 Exp Date 04/30/2001

____ (This section need not be completed if the permits for \$100 or less) I certify that in the performance of the work for which this permit is issued, I shall not employ any person in any manner so as to become subject to the workers' compensation laws of California and agree that if I should become subject to the workers' compensation provisions of Section 3700 of the Labor Code, I shall forthwith comply with those provisions.

X Date 2-25-2000 Applicant Signature [Signature]

WARNING: FAILURE TO SECURE WORKER'S COMPENSATION COVERAGE IS UNLAWFUL AND SHALL SUBJECT AN EMPLOYER TO CRIMINAL PENALTIES AND CIVIL FINES UP TO ONE HUNDRED THOUSAND DOLLARS (\$100,000) IN ADDITION TO THE COST OF COMPENSATION, DAMAGES AS PROVIDED FOR IN SECTION 3706 OF THE LABOR CODE, INTEREST AND ATTORNEY'S FEE.

THIS PERMIT SHALL EXPIRE BY LIMITATION IF WORK IS NOT COMMENCED WITHIN 180 DAYS.

Date of Request: _____

By: _____

**CITY OF SACRAMENTO DEVELOPMENT SERVICES DIVISION
PLANNING AND ZONING INFORMATION REQUEST**

Project Address: 527 1/2 L STREET

Assessor's Parcel Number: 008-0232-038

Previous Use: SFR.

Description of Request/Proposed Use: ADD SUNROOM @ EAST SIDE

Is This a Change of Use? NO.

Prior Applications for Project Site(P#, Z#, DRPB#): Ø Zoning Designation: R-1

Comments: WANTS TO CONSTRUCT 200 SF SUNROOM.; LOT COVERAGE OK, SB OK ; NO PLANNING ENTITLEMENTS REQUIRED.

Are There Any Planning Issues?: (circle one) YES NO

- * Staff Site Plan Check Required? (Circle one) YES NO
- * Field Inspection Required? (Circle one) YES NO
- * Design Review/Preservation Required? (Circle one) YES NO

Planning Review by/Date: [Signature] 2/25/00

A list of items that must be reviewed by Planning is provided on the reverse side of this form.

MICROFILM AFTER FINAL

I.R. ROBERTS, ARCHITECT
5276 E. 7th STREET
SACRAMENTO, CALIF. 95812
452-4261

7" STREET

5276
7"
STREET

Garage

D
R
I
V
E
R
A
Y

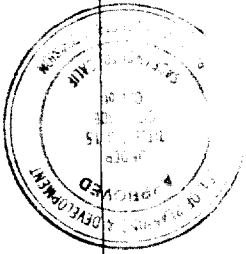
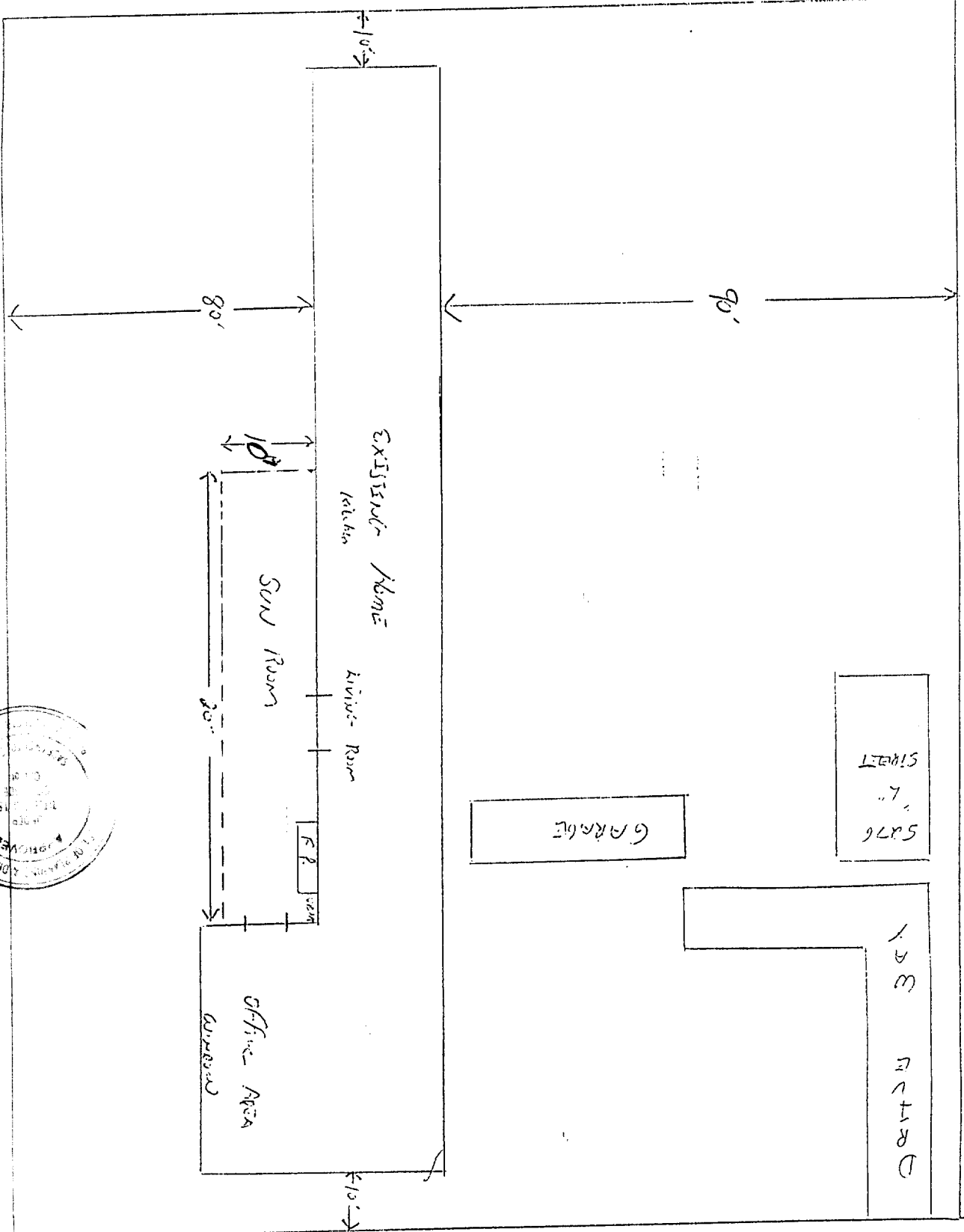

This is kept on same w Building The SHALL violation
ISS
FEB
Sacramento

THIS DRAWING IS THE PROPERTY OF AIRFLO INDUSTRIES, INC. IT IS TO BE USED ONLY FOR THE PROJECT AND LOCATION SPECIFICALLY IDENTIFIED HEREON. IT IS NOT TO BE REPRODUCED, COPIED, OR TRANSMITTED IN ANY FORM OR BY ANY MEANS, ELECTRONIC OR MECHANICAL, INCLUDING PHOTOCOPYING, RECORDING, OR BY ANY INFORMATION STORAGE AND RETRIEVAL SYSTEM, WITHOUT THE WRITTEN PERMISSION OF AIRFLO INDUSTRIES, INC.

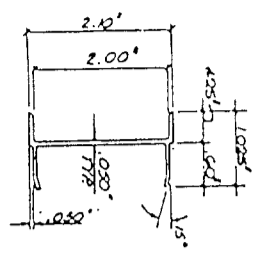
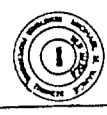

MALE "H" 1

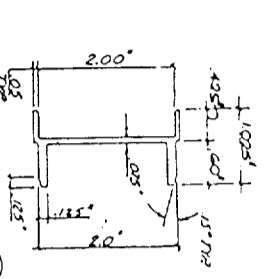

HO MALE "H" 2

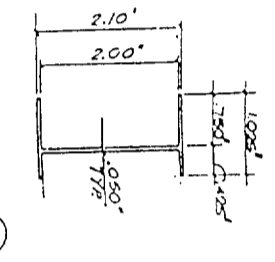

FEMALE "H" 3

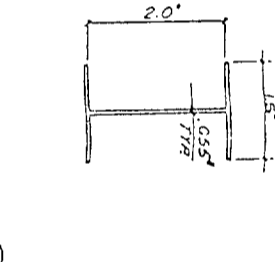

STANDARD "H" 4

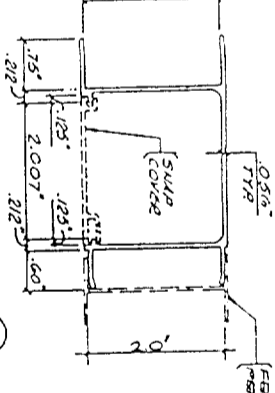

ER "H" 5

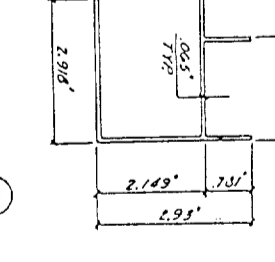

CORNER POST 6

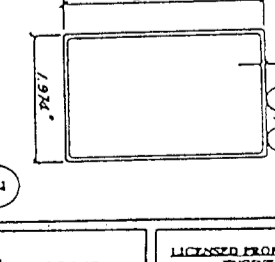

S.R. POST 7

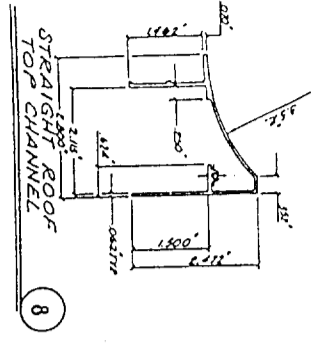

STRAIGHT ROOF TOP CHANNEL 8

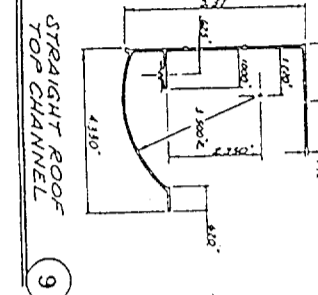

STRAIGHT ROOF TOP CHANNEL 9

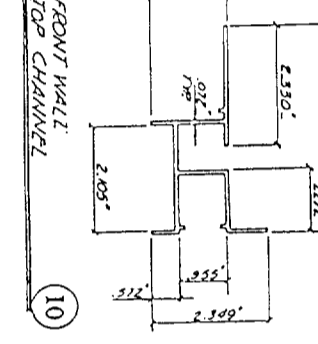

FRONT WALL TOP CHANNEL 10

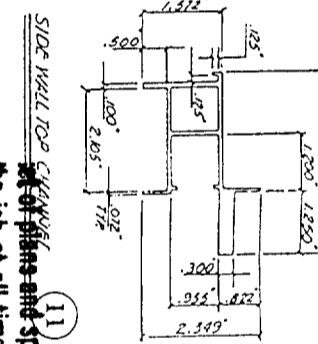

SIDE WALL TOP CHANNEL 11

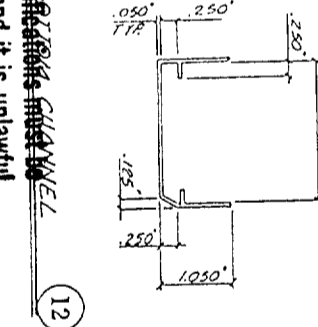

SR SIDEWALL TOP CHANNEL 13

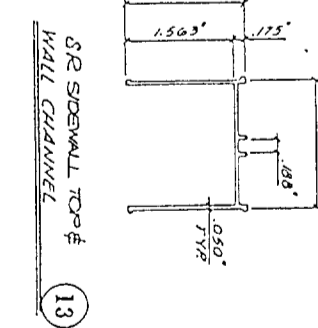

TOP CHANNEL INSERT 14

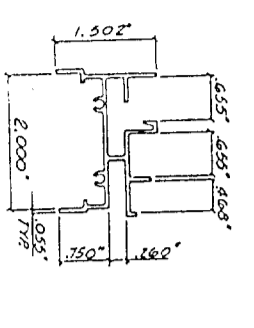

SLIDING WINDOW SILL 15

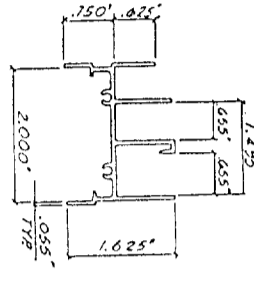

SLIDING WINDOW HEAD 16

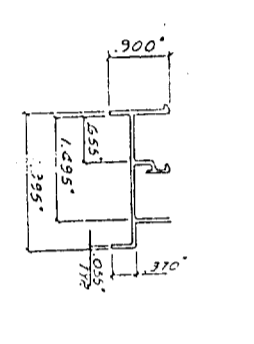

SLIDING WINDOW SIDE 17

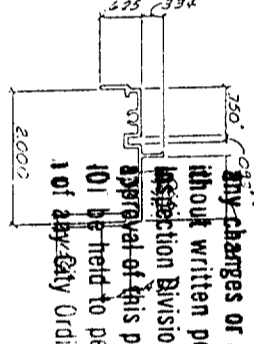

FIXED GLAZING HEAD & SILL 18

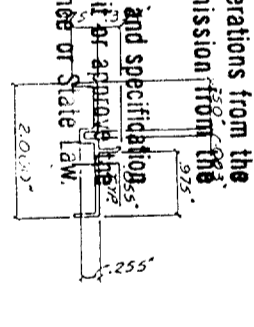

FIXED GLAZING SIDE 19

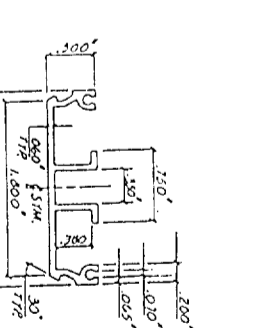

GLAZING TRAY 20

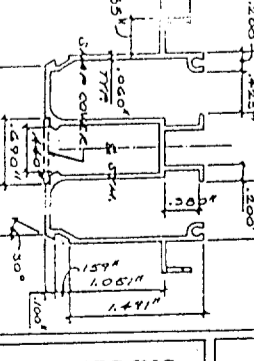

GLAZING TRAY 21

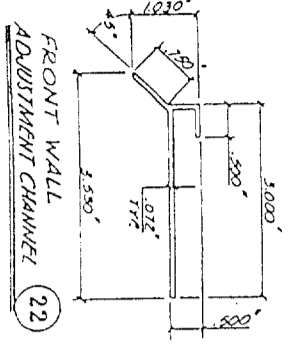

FRONT WALL ADJUSTMENT CHANNEL 22

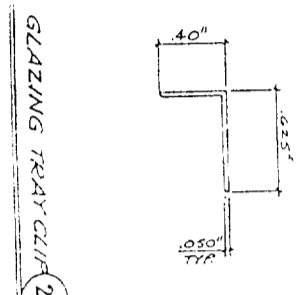

GLAZING TRAY CLIP 23

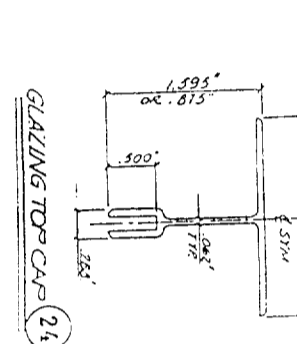

GLAZING TOP CAP 24

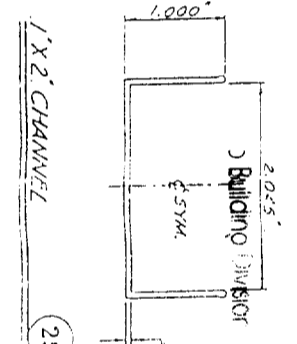

1' X 2' CHANNEL 25

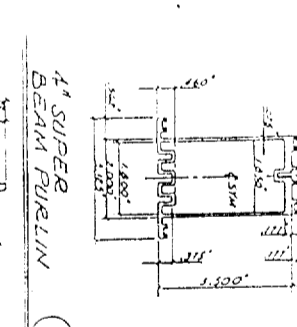

4' SUPER BEAM PURLIN 26

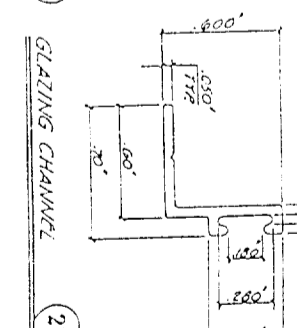

GLAZING CHANNEL 27

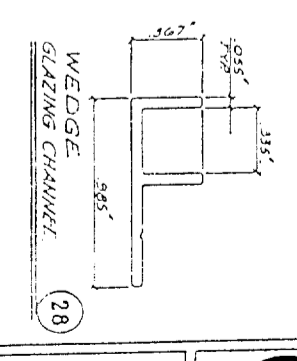

WEDGE GLAZING CHANNEL 28

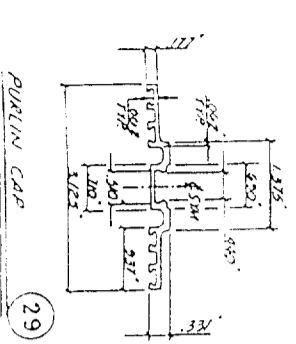

PURLIN CAP 29

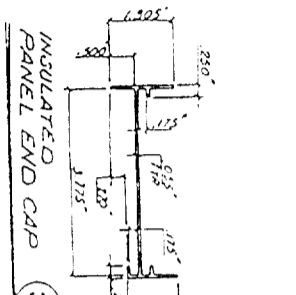

INSULATED PANEL END CAP 30

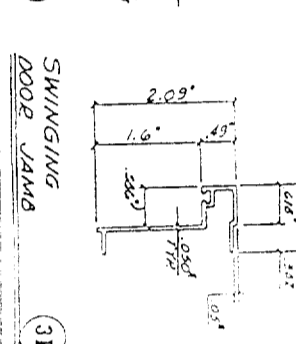

SWINGING DOOR JAMB 31

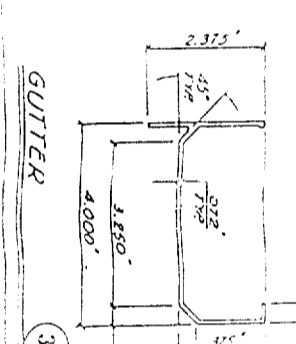

GUTTER 32

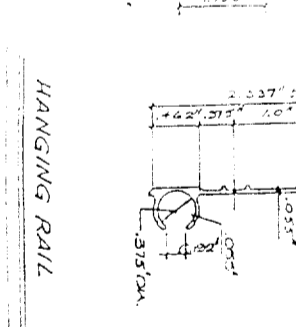

HANGING RAIL 33

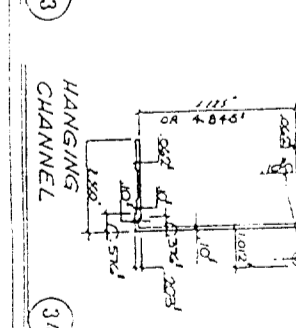

HANGING CHANNEL 34

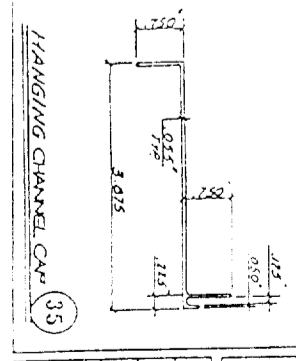

HANGING CHANNEL CAP 35

USEC
 Approval of this plan and specification, in whole or in part, by the City Engineer or State Engineer, does not constitute a warranty or endorsement of the product or the quality of the workmanship. The user of this plan and specification is responsible for obtaining all necessary permits and for complying with all applicable codes and ordinances. The user of this plan and specification is responsible for obtaining all necessary permits and for complying with all applicable codes and ordinances.

MAY BE USED AS ALTERNATE TO MATED (1) & (3) WILLON

SEE DETAILS (H) & (D)

DATE: OCT 1995
 JOB NO.: H-194
 DRAWN BY: J.A.
 DWG. NO.: ER-1

"ELITE" & "ECLIPSE"
 PARTS DETAILS

AIRFLO INDUSTRIES, INC.
 130 W. VICTORIA STREET
 GARDENA, CALIF. 90248
 (310)217-9900 (800)726-8428

ICBO EVALUATION SERVICE INC. REPORT NO. 3421P

ASHITON VANCE & ASSOC., INC.
 LICENSED PROFESSIONAL ENGINEER
 ARIZONA CALIFORNIA
 COLORADO FLORIDA ILLINOIS
 IOWA MINNESOTA NEW MEXICO
 OREGON UTAH WASHINGTON
 (909) 928-8183

LICENSED PROFESSIONAL ENGINEER
 ARIZONA CALIFORNIA
 COLORADO FLORIDA ILLINOIS
 IOWA MINNESOTA NEW MEXICO
 OREGON UTAH WASHINGTON

ALL DIMENSIONS UNLESS OTHERWISE SPECIFIED ARE IN INCHES. DIMENSIONS IN PARENTHESES ARE IN MILLIMETERS. DIMENSIONS IN FEET AND INCHES ARE TO FACE UNLESS OTHERWISE SPECIFIED.

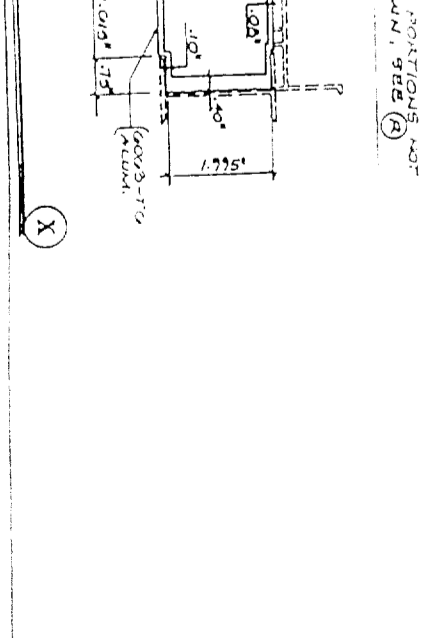
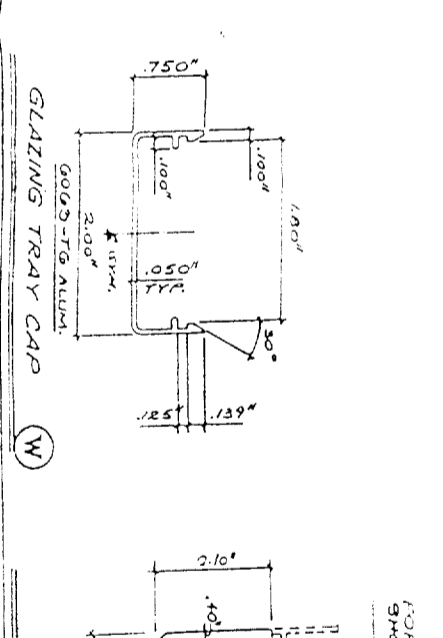
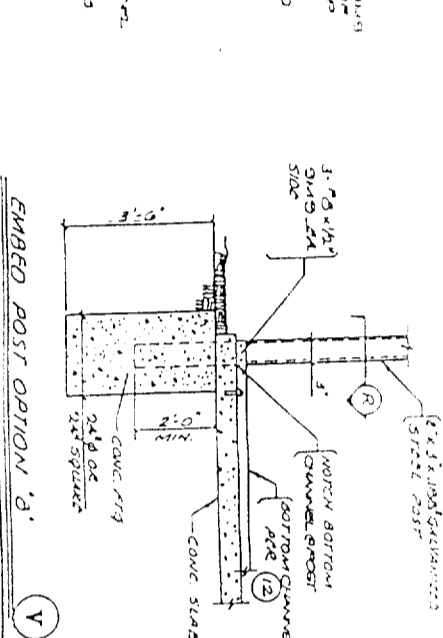
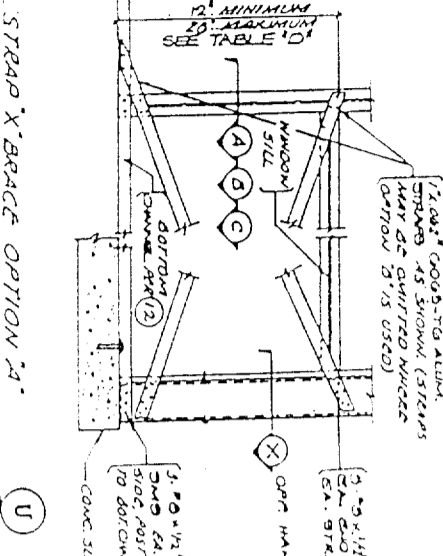
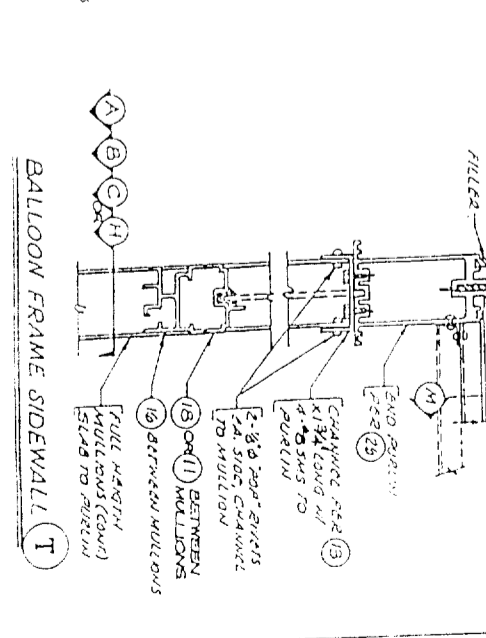
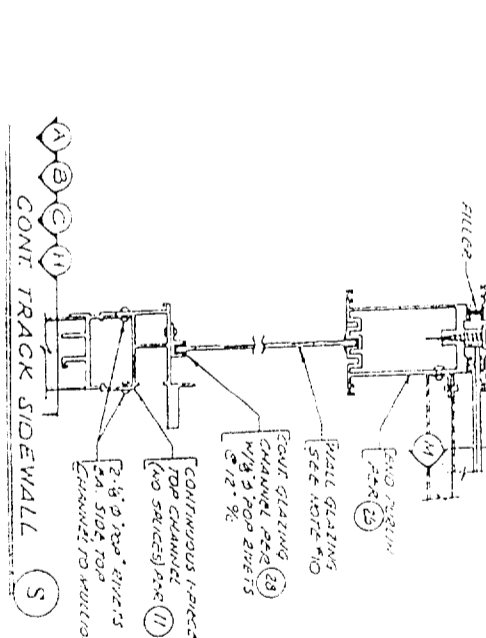
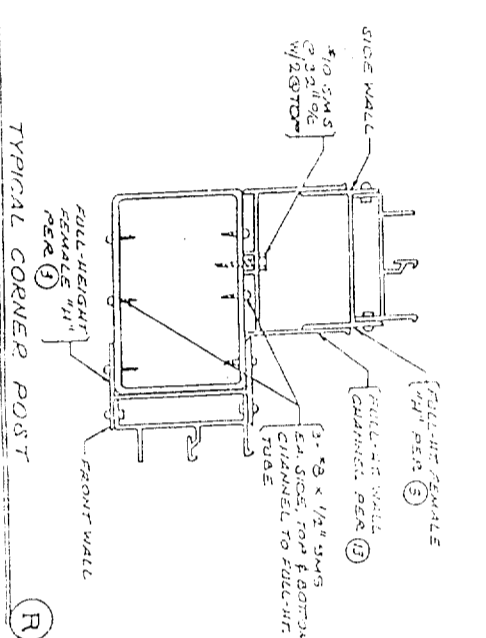
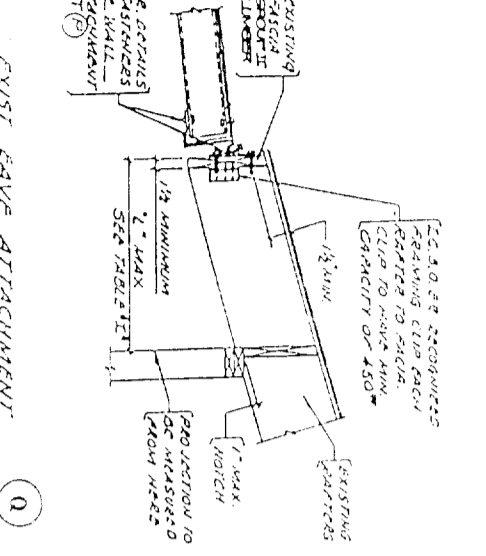
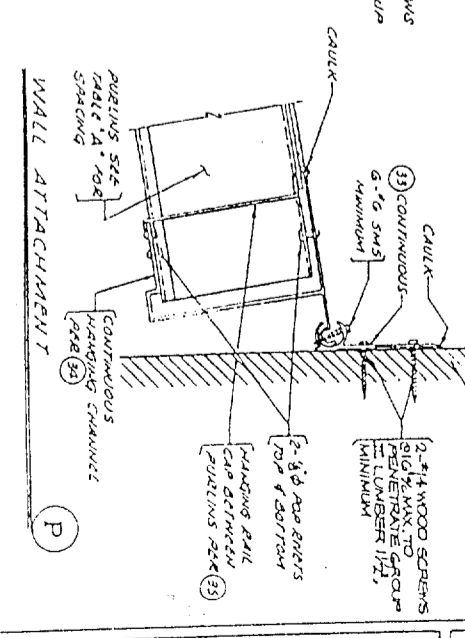
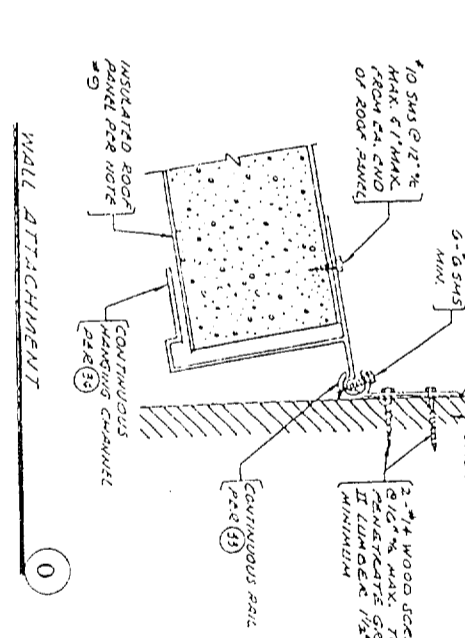
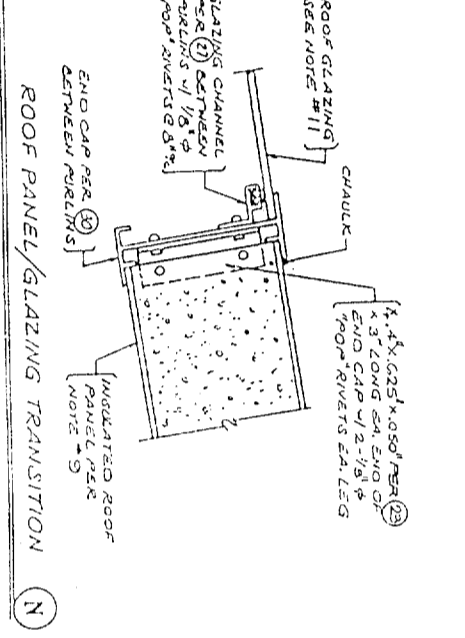
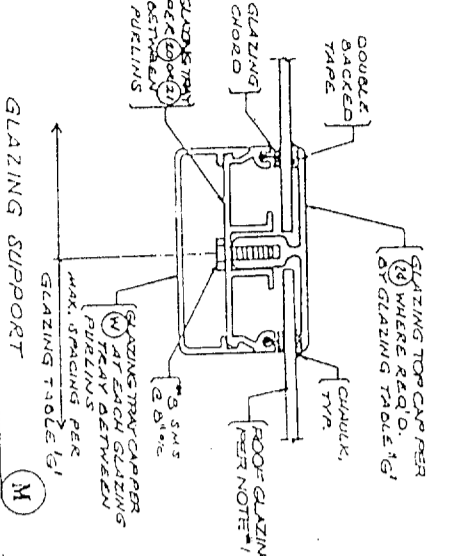
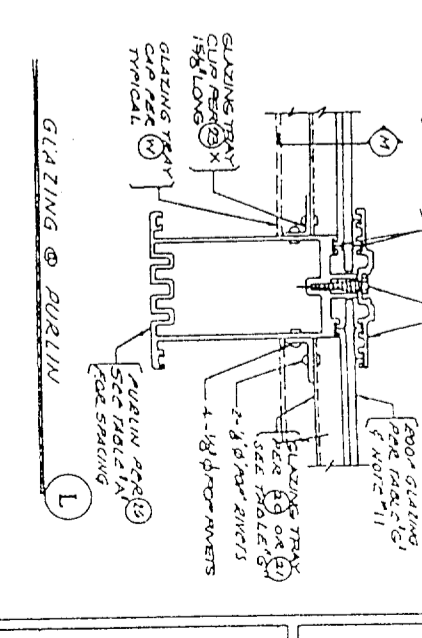
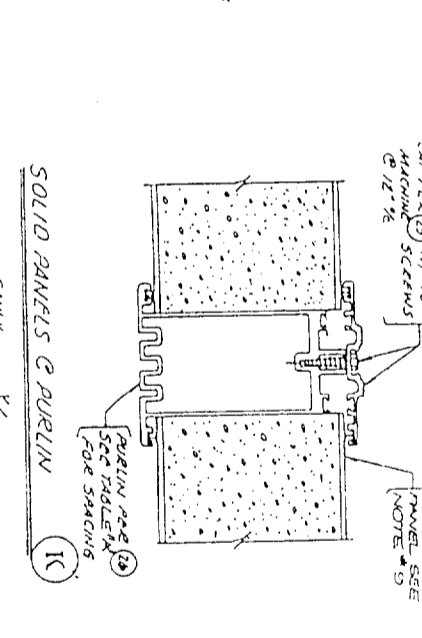
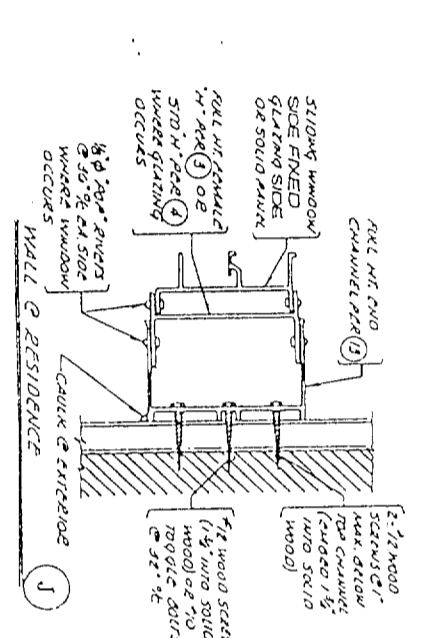
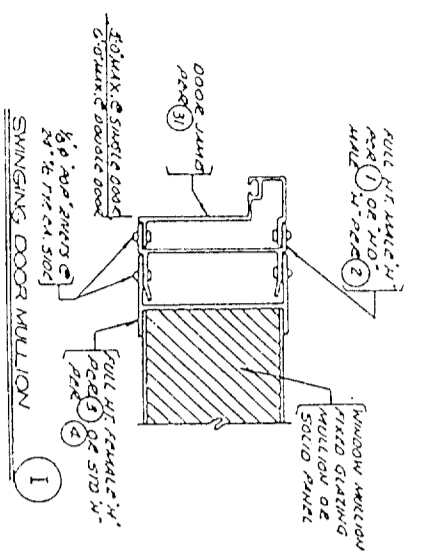

LICENSED PROFESSIONAL ENGINEER
ASHTON VANCE & ASSOC. INC.
11115

ASHTON VANCE & ASSOC. INC.
11115

ICBO EVALUATION SERVICE INC. REPORT NO. 3421P

AIRFLO INDUSTRIES, INC.
130 W. VICTORIA STREET GARDENA, CALIF. 90240
(310)217-9900 (800)728-8426

"ELITE" & "ECLIPSE" ASSEMBLY DETAILS
DATE: 01/19/95
DRAWN BY: J.A.K.
DWG. NO.: ER-3