

**CITY OF SACRAMENTO**

**Permit No: 0114529**

**1231 I Street, Sacramento, CA 95814**

**Insp Area: 1**  
**Thos Bros: 297 C3**

**Site Address: 429 J ST SAC**

**Sub-Type: REM**

**Parcel No: 006-0024-045**

**FIRST FLOOR**

**Housing (Y/N): N**

**CONTRACTOR**

GABLE CONSTRUCTION  
3204 CORNICHE LN  
ROSEVILLE CA 95661

**OWNER**

MAGILL  
1307 W 8TH ST  
DAVIS CA 95616

**ARCHITECT**

**Nature of Work: PROVIDE CIRCUIT FOR DOOR OPENER**

**CONSTRUCTION LENDING AGENCY:** I hereby affirm under penalty of perjury that there is a construction lending agency for the performance of the work for which this permit is issued (Sec. 3097, Civ. C).

Lender's Name \_\_\_\_\_ Lender's Address \_\_\_\_\_

**LICENSED CONTRACTORS DECLARATION:** I hereby affirm under penalty of perjury that I am licensed under provisions of Chapter 9 (commencing with section 7000) of Division 3 of the Business and Professions Code and my license is in full force and effect.

License Class B License Number 752142 Date 11-8-01 Contractor Signature [Signature]

**OWNER-BUILDER DECLARATION:** I hereby affirm under penalty of perjury that I am exempt from the contractors License Law for the following reason (Sec. 7031.5, Business and Professions Code; any city or county which requires a permit to construct, alter, improve, demolish, or repair any structure, prior to its issuance, also requires the applicant for such permit to file a signed statement that he or she is licensed pursuant to the provisions of the Contractors License Law (Chapter 9 (commencing with Section 7000) of Division 8 of the Business and Professions Code) or that he or she is exempt therefrom and the basis for the alleged exemption. Any violation of Section 7031.5 by any applicant for a permit subjects the applicant to a civil penalty of not more than five hundred dollars (\$500.00);

I, as a owner of the property, or my employees with wages as their sole compensation, will do the work, and the structure is not intended or offered for sale (Sec. 7044, Business and Professional Code: The Contractors License Law does not apply to an owner of property who builds or improves thereon, and who does such work himself or herself or through his/her own employees, provided that such improvements are not intended or offered for sale. If, however, the building or improvement is sold within one year of completion, the owner-builder will have the burden of proving that he/she did not build or improve for the purpose of sale.)

I, as owner of the property, am exclusively contracting with licensed contractors to construct the project (Sec. 7044, Business and Professions Code: The Contractors License Law does not apply to an owner of property who builds or improves thereon, and who contracts for such projects with a contractor(s) licensed pursuant to the Contractors License Law).

I am exempt under Sec. \_\_\_\_\_ B & PC for this reason: \_\_\_\_\_

Date \_\_\_\_\_ Owner Signature \_\_\_\_\_

**IN ISSUING THIS BUILDING PERMIT,** the applicant represents, and the city relies on the representation of the applicant, that the applicant verified all measurements and locations shown on the application or accompanying drawings and that the improvement to be constructed does not violate any law or private agreement relating to permissible or prohibited locations for such improvements. This building permit does not authorize any illegal location of any improvement or the violation of any private agreement relating to location of improvements.

I certify that I have read this application and state that all information is correct. I agree to comply with all city and county ordinances and state laws relating to building construction and hereby authorize representative(s) of this city to enter upon the abovementioned property for inspection purposes.

Date 11-8-01 Applicant/Agent Signature [Signature]

**WORKER'S COMPENSATION DECLARATION:** I hereby affirm under penalty of perjury one of the following declarations:

I have and will maintain a certificate of consent to self-insure for workers' compensation as provided for by Section 3700 of the Labor Code, for the performance of work for which the permit is issued.

I have and will maintain workers' compensation insurance, as required by Section 3700 of the Labor Code, for the performance of the work for which this permit is issued. My workers' compensation insurance carrier and policy number are:

Carrier NONE Policy Number \_\_\_\_\_ Exp Date \_\_\_\_\_

(This section need not be completed if the permit is for \$100 or less) I certify that in the performance of the work for which this permit is issued, I shall not employ any person in any manner so as to become subject to the workers' compensation laws of California and agree that if I should become subject to the workers' compensation provisions of Section 3700 of the Labor Code, I shall forthwith comply with those provisions.

Date 11-8-01 Applicant Signature [Signature]

**WARNING: FAILURE TO SECURE WORKER'S COMPENSATION COVERAGE IS UNLAWFUL AND SHALL SUBJECT AN EMPLOYER TO CRIMINAL PENALTIES AND CIVIL FINES UP TO ONE HUNDRED THOUSAND DOLLARS (\$100,000) IN ADDITION TO THE COST OF COMPENSATION, DAMAGES AS PROVIDED FOR IN SECTION 3706 OF THE LABOR CODE, INTEREST AND ATTORNEY'S FEE.**

**THIS PERMIT SHALL EXPIRE BY LIMITATION IF WORK IS NOT COMMENCED WITHIN 180 DAYS.**

**PLANNING AND ZONING REVIEW**

..... to be filled out by Planning staff .....

ADDRESS: 429 S

APN: 006-0024-045 ZONING: C-3

DESIGN REVIEW AREA: CENTRAL CITY

PREVIOUS FILES RELATED TO SITE: DR 99-071

EXISTING LAND USE: ASIAN PAVILLION

PROPOSED USE: INSTALL HANDICAP DOOR  
OPENER

COMMENTS: NO PLANNING ISSUES OR  
DESIGN REVIEW ISSUES

DATE: 11-8-01 BY: MSY

DOES IT APPEAR THAT THE PROJECT WILL REQUIRE A PLANNING APPLICATION?  
YES  **NO**  (If yes, circle applications needed below)

.....Staff.....ZA.....Planning Commission.....Design Review.....Preservation Review.....

CONCLUSION: \_\_\_\_\_

DATE: 11-8-01 BY: MSY

**APPLICATION FOR COMMERCIAL BUILDING PERMIT**

**CITY OF SACRAMENTO**  
 DEVELOPMENT SERVICES DIVISION  
 PERMIT SERVICES SECTION  
 1231 I Street, Rm. 200  
 Sacramento, CA 95814 (916) 264-7619 FAX 264-7046

ACTIVITY # 0114529 Insp. Area C

Applicant **MUST** complete ALL Unshaded areas

ADDRESS 429 J. ST. Suite 1ST FLR  
 PARCEL # 006.0024.045

<p align="center"><b>CONTACT</b></p> Name <u>MARK BETTENHASEN</u> Street Address <u>3204 CORNICHE Ckt</u> City/State/Zip <u>ROSEVILLE CA 95061</u> Phone <u>916 223 0153</u> FAX <u>916 797 0373</u> E-mail: _____	<p align="center"><b>LICENSED CONTRACTOR</b> Lic No. # <u>B 752142</u></p> Name <u>CABLE CONDT.</u> Address <u>11</u> City/State/Zip _____ Phone _____ FAX _____ E-mail: _____
<p align="center"><b>ARCHITECT/ENGINEER</b></p> Name <u>NA</u> Address _____ City/State/Zip _____ Phone _____ FAX _____ E-mail: _____	<p align="center"><b>OWNER</b></p> Name <u>MARVIN PROPERTIES</u> Address <u>1307 W 8th ST</u> City/State/Zip <u>DAVIS CA 95616</u> Phone _____ FAX _____ E-mail: _____

→ Will permittee have any employees on the jobsite?  No  Yes → INSURANCE CO: \_\_\_\_\_  
 → WORKER'S COMPENSATION POLICY # \_\_\_\_\_ EXPIRATION DATE: \_\_\_\_\_

NATURE OF WORK IN DETAIL: INSTALL ELECTRIC DOOR OPENER TO REAR DOOR (STORE FRONT TYPE) 36" DOOR, DOUBLE SWING, ONE DOOR. PROVIDE CIRCUIT FOR DOOR OPENER

OCCUPANT/TENANT: WEST ED VALUATION: \$ 4K

FLOOD STATUS:		S.C.A.T.								
JOB DESCRIPTION		BLDG	SHELL	APT	TI ( )	REM ( )	SW	FIRE	ADD	OTH
INSPECTION DISCIPLINES		BLDG	MECH	PLUMB	ELEC	SITE	FIRE			
# Stories	1st flr Area	Total Area	Use Zone	Occp Group	Const type	Fire Req. Y / N		Fed Code	Vio. File	
<u>4</u>						SPR	ALARM		[H]	[Quad]
<u>(B)</u>	<u>(L)</u>	<u>P</u>	<u>M</u>	<u>(E)</u>	<u>F</u>	<u>S</u>	<u>D</u>	<u>PW</u>	<u>UTIL</u>	
<u>13 ft</u>	<u>13 ft</u>			<u>BTM</u>						

COMMENTS: \_\_\_\_\_  
 \_\_\_\_\_  
 \_\_\_\_\_

REGIONAL SANITATION FEES?  Yes  No HEALTH DEPARTMENT?  Yes  No  
 WATER FLOW TEST FOR NEW BUILDINGS OR ADDITIONS?  Provided  Faxed

dssu/forms/commercialapp. [rev. 03/28/00]

0114529

429 J ST

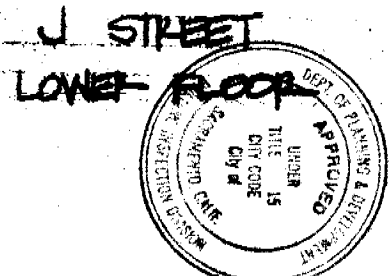
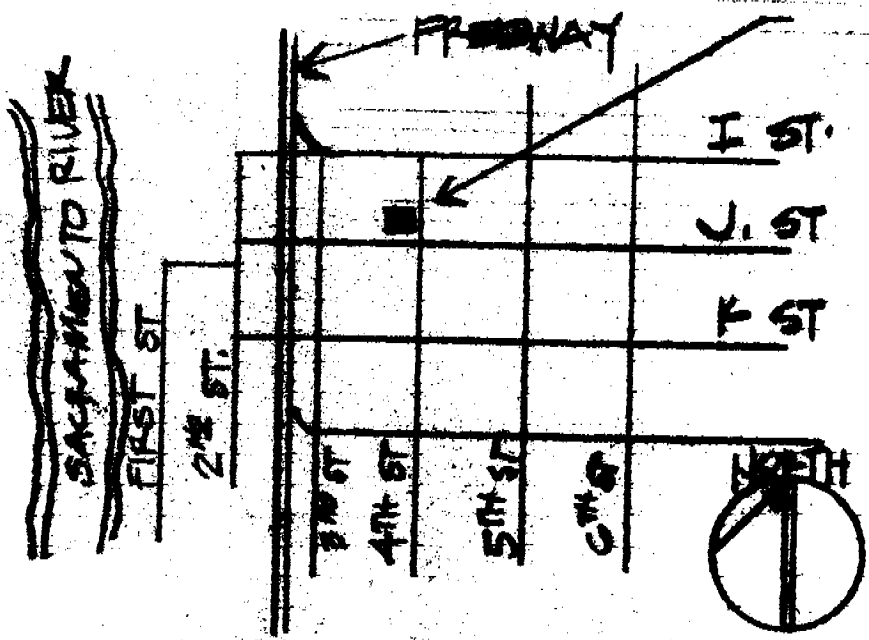

This set of plans and specifications must be kept on the job at all times and it is unlawful to make any changes or alterations from the same without written permission from the Building Inspection Division.  
 The approval of this plan and specification SHALL NOT be held to permit or approve the violation of any City Ordinance or State Law.

VICINITY MAP NO SCALE

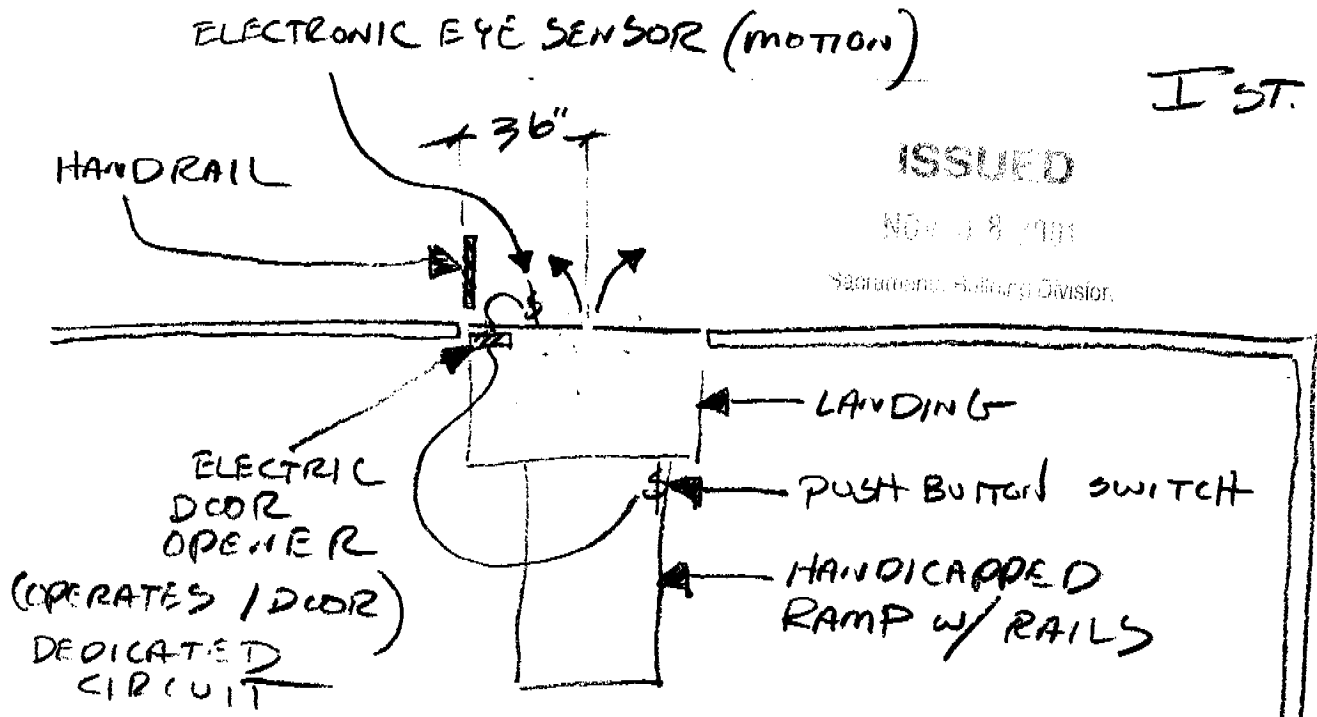

ISSUED  
 NOV 18 2001  
 Sacramento Building Division

MAGILL PROPERTIES  
 29 J ST.  
 ELECTRIC DOOR OPENER  
 (REAR ENTRANCE)

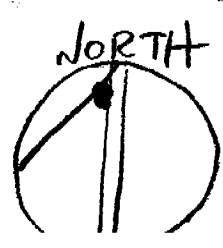

J ST. John Tang

231280

**TRANSIT 97 TOPOGRAPHICAL DIAGRAM**

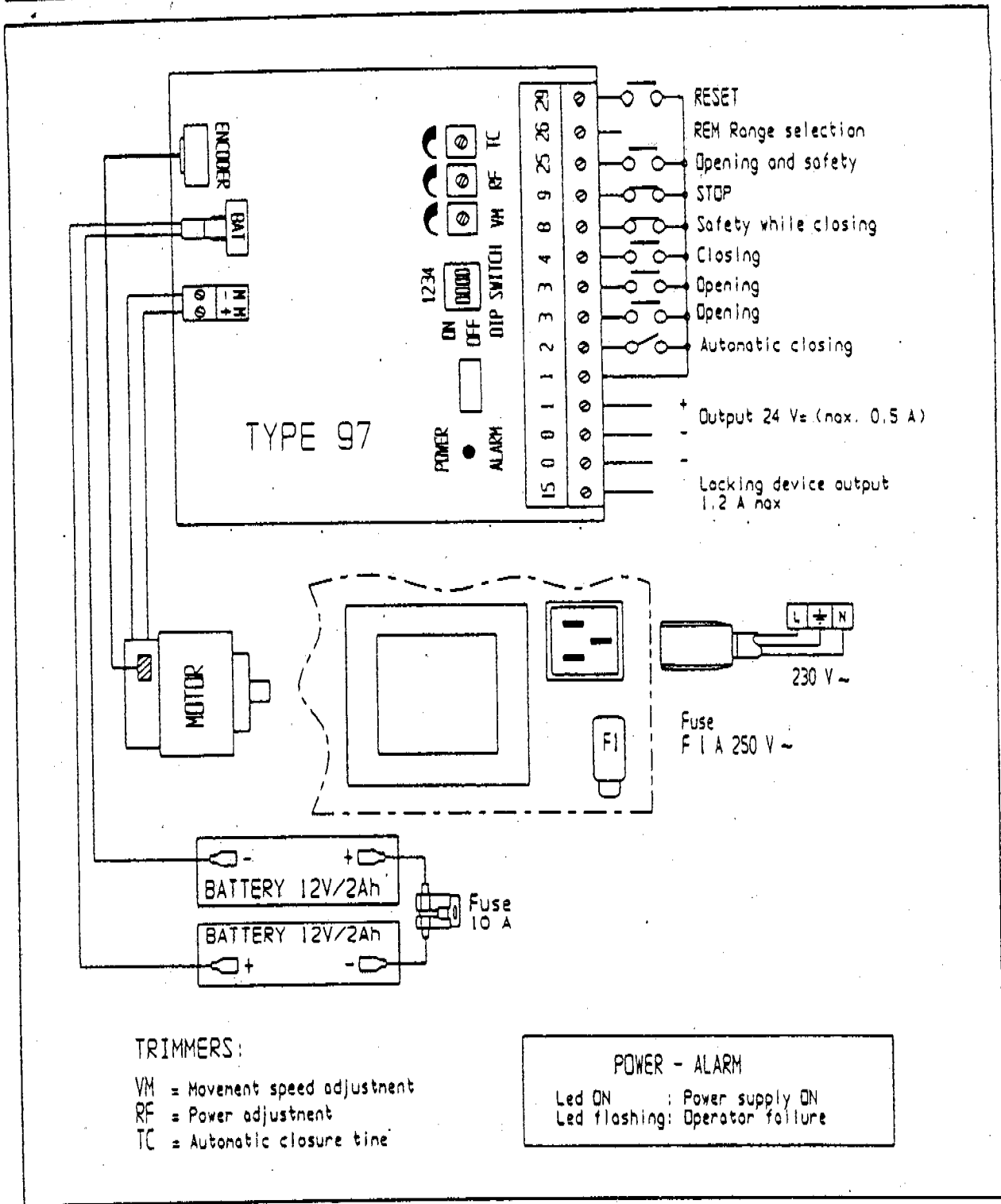

TRIMMERS:  
 VM = Movement speed adjustment  
 RF = Power adjustment  
 TC = Automatic closure time

POWER - ALARM  
 Led ON : Power supply ON  
 Led flashing: Operator failure

**DIP SWITCHES**

DIP	FUNCTION	OFF	ON
D1	Electric lock command	Contemporary command	In advance command
D2	Closing click	Disabled	Enabled
D3	Opening by pushing	Disabled	Enabled
D4	Not used		

### ARTICULATED ARM

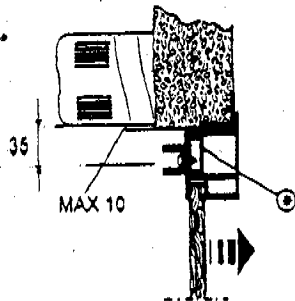

Remove the jaw of the articulated arm and fix it to the door.

The reinforcement  is not supplied by us.

### SLIDING ARM

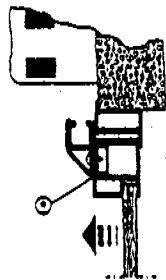

Secure the slide on the door.

The reinforcement  is not supplied by us.

**Warning:** Journal C rotation shall not exceed 170°. When open, the door leaf shall lean against the doorstop of the maximum arm extension or on the floor doorstop. Doors subject to current of air shall lean, in the opening against the floor doorstop.

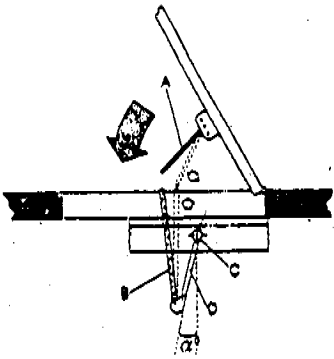

Separate the threaded bar A from the perforated tube B. Secure the threaded bar A to the jaw of the door.

Fix the journal C of the arm D moving up of one tooth the perpendicular  $\alpha^\circ$  to the operator.

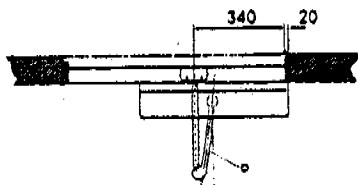

Close the door completely and secure the bar A and the perforated tube B one to the other. In order to centre holes and threads, gently push the pivot of the arm D in the opening direction of the door.

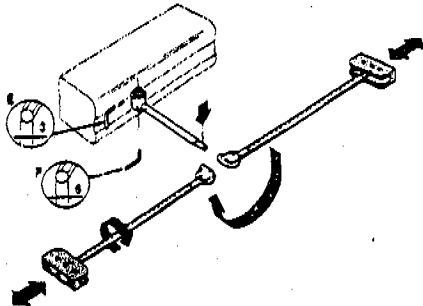

Remove the shim P850. If the bar A and the tube B were too long, cut the excess off. Tighten the fastening screw F and block it with the grub screw M6 E.

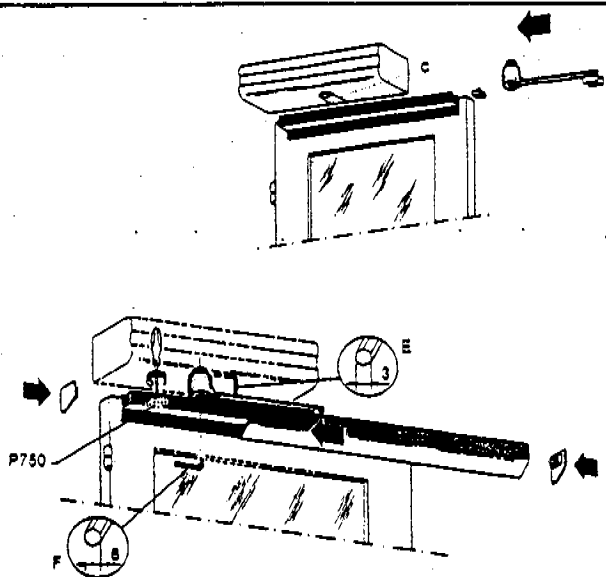

Pass the sliding boss in the groove of the flange that is fixed on the door. When the door is completely closed, fix the rotation arm. Tighten the fastening screw F and block it with the grub screw M6 E.

In order to centre the tooth formation, move the little belt of the geared motor. Remove the shim P850.

Open the door at 90° and fix the travel limiter P750 at 5 mm from the sliding boss of the arm. Insert the groove cover and the heads.

### CHARACTERISTICS

Motorized opening	
Opening speed	3 + 6 s
Closing speed	= 70% opening speed
Built-in anti-squeezing device	
Articulated arm it opens by pushing	
Sliding arm it opens by pulling	
Spring closing for SUPERTRANSIT 95	
Motorized closing for TRANSIT 97	
Trimmer regulation	
Encoder Limit switch	
Processor logic	