

**CITY OF SACRAMENTO**  
1231 I Street, Sacramento, CA 95814

**Permit No: 0401496**  
**Insp Area: 2**  
**Thos Bros: 358-D2**

**Site Address: 8609 JOCELYN WY SAC**  
Parcel No: 117-1420-010 LAGUNA VISTA LOT 10

**Sub-Type: NSFR**  
**Housing (Y/N): N**

CONTRACTOR  
WOODSIDE HOMES OF N. CALIF.  
15 AUTO PLAZA DR #102  
FOLSOM CA. 95630

OWNER

ARCHITECT

**Nature of Work: MP 1875 2 STORY 8 ROOM SFR**

**CONSTRUCTION LENDING AGENCY :** I hereby affirm under penalty of perjury that there is a construction lending agency for the performance of the work for which this permit is issued (Sec. 3097, Civ. C).

Lender's Name \_\_\_\_\_ Lender's Address \_\_\_\_\_

**LICENSED CONTRACTORS DECLARATION:** I hereby affirm under penalty of perjury that I am licensed under provisions of Chapter 9 (commencing with section 7000) of Division 3 of the Business and Professions Code and my license is in full force and effect.

License Class B License Number 744379 Date 2-3-04 Contractor Signature Kerou McAsst

**OWNER-BUILDER DECLARATION:** I hereby affirm under penalty of perjury that I am exempt from the contractors License Law for the following reason (Sec. 7031.5, Business and Professions Code; any city or county which requires a permit to construct, alter, improve, demolish, or repair any structure, prior to its issuance, also requires the applicant for such permit to file a signed statement that he or she is licensed pursuant to the provisions of the Contractors License Law (Chapter 9 (commencing with Section 7000) of Division 8 of the Business and Professions Code) or that he or she is exempt therefrom and the basis for the alleged exemption. Any violation of Section 7031.5 by any applicant for a permit subjects the applicant to a civil penalty of not more than five hundred dollars (\$500.00);

\_\_\_\_ I, as a owner of the property, or my employees with wages as their sole compensation, will do the work, and the structure is not intended or offered for sale (Sec. 7044, Business and Professional Code: The Contractors License Law does not apply to an owner of property who builds or improves thereon, and who does such work himself or herself or through his/her own employees, provided that such improvements are not intended or offered for sale. If, however, the building or improvement is sold within one year of completion, the owner-builder will have the burden of proving that he/she did not build or improve for the purpose of sale.)

\_\_\_\_ I, as owner of the property, am exclusively contracting with licensed contractors to construct the project (Sec. 7044, Business and Professions Code: The Contractors License Law does not apply to an owner of property who builds or improves thereon, and who contracts for such projects with a contractor(s) licensed pursuant to the Contractors License Law).

\_\_\_\_ I am exempt under Sec. \_\_\_\_\_ B & PC for this reason: \_\_\_\_\_

Date \_\_\_\_\_ Owner Signature \_\_\_\_\_

**PAID**  
**CITY OF SACRAMENTO**  
**FEB 03 2004**  
**PERMIT CENTER**

**IN ISSUING THIS BUILDING PERMIT,** the applicant represents, and the city relies on the representation of the applicant, that the applicant verified all measurements and locations shown on the application or accompanying drawings and that the improvement to be constructed does not violate any law or private agreement relating to permissible or prohibited locations for such improvements. This building permit does not authorize the illegal location of any improvement or the violation of any private agreement relating to location of improvements.

I certify that I have read this application and state that all information is correct. I agree to comply with all city and county ordinances and state laws relating to building construction and hereby authorize representative(s) of this city to enter upon the abovementioned property for inspection purposes.

Date 2-3-04 Applicant/Agent Signature Kerou McAsst

**WORKER'S COMPENSATION DECLARATION:** I hereby affirm under penalty of perjury one of the following declarations:  
\_\_\_\_ I have and will maintain a certificate of consent to self-insure for workers' compensation as provided for by Section 3700 of the Labor Code, for the performance of work for which the permit is issued.

I have and will maintain workers' compensation insurance, as required by Section 3700 of the Labor Code, for the performance of the work for which this permit is issued. My workers' compensation insurance carrier and policy number are:

Carrier INSURANCE CO. OF THE WEST Policy Number WSD1701245-01 Exp Date 12/12/2003

\_\_\_\_ (This section need not be completed if the permit is for \$100 or less) I certify that in the performance of the work for which this permit is issued, I shall not employ any person in any manner so as to become subject to the workers' compensation laws of California and agree that if I should become subject to the workers' compensation provisions of Section 3700 of the Labor Code, I shall forthwith comply with those provisions.

Date 2-3-04 Applicant Signature Kerou McAsst

**WARNING: FAILURE TO SECURE WORKER'S COMPENSATION COVERAGE IS UNLAWFUL AND SHALL SUBJECT AN EMPLOYER TO CRIMINAL PENALTIES AND CIVIL FINES UP TO ONE HUNDRED THOUSAND DOLLARS (\$100,000) IN ADDITION TO THE COST OF COMPENSATION, DAMAGES AS PROVIDED FOR IN SECTION 3706 OF THE LABOR CODE, INTEREST AND ATTORNEY'S FEE.**

**THIS PERMIT SHALL EXPIRE BY LIMITATION IF WORK IS NOT COMMENCED WITHIN 180 DAYS.**

RESIDENTIAL SUBDIVISION BUILDING PERMIT APPLICATION

Project Address: 8609 Joeelyn Way  
Lot Number: 10

Assessor Parcel # 117-1420-010  
Subdivision Laguna Vista

OWNER INFORMATION:

Legal Property Owner: Woodside Laguna Vista, Inc. Phone# (916) 608-9600  
Owner Address: 15 Plaza Drive #102 City Folsom State CA Zip 95630

CONTRACTOR INFORMATION:

Contractor: Woodside Homes of CA, Inc. # 744379B Phone # 608-9600 Fax 608-9940

PROJECT INFORMATION:

Land Use Zone RIA Occupancy Group R3 Construction Type VN Fed Code 1A  
 No. of Stories: 2 No. of Rooms: \_\_\_\_\_ Street Width: \_\_\_\_\_  
 1<sup>st</sup> Floor Area 958 2<sup>nd</sup> Floor Area 917 Basement N/A Roof Material Concrete Tile

AREA IN SQUARE FOOT OF:

Dwelling/Living	<u>1875</u>
Garage/Storage	<u>459</u>
Decks/Balconies	<u>N/A</u>
Carports	<u>N/A</u>

SCOPE OF WORK: New Residential Construction

FOR OFFICE USE ONLY

- Information Above Complete
- Violation Files Checked
- Standard Setbacks
- County Sewer
- AR Flood Waiver Required
- Flood Elevation Certificate Required
- Water Development Infill Area
- Planning Approval
- Design Review Approval
- Special Fee Districts Apply:

**THE FOLLOWING MUST BE PROVIDED IN ORDER TO SUBMIT FOR PERMIT**

- 2 COMPLETE PLOT PLANS, LEGIBLE & DRAWN TO SCALE
- 11 X 17 COPY OF FLOOR PLAN WITH FOLLOWING INFORMATION
  - a) Assessor's Parcel Number
  - b) New Floor Area
  - c) Owners Name
  - d) Project Address

# PLOT PLAN

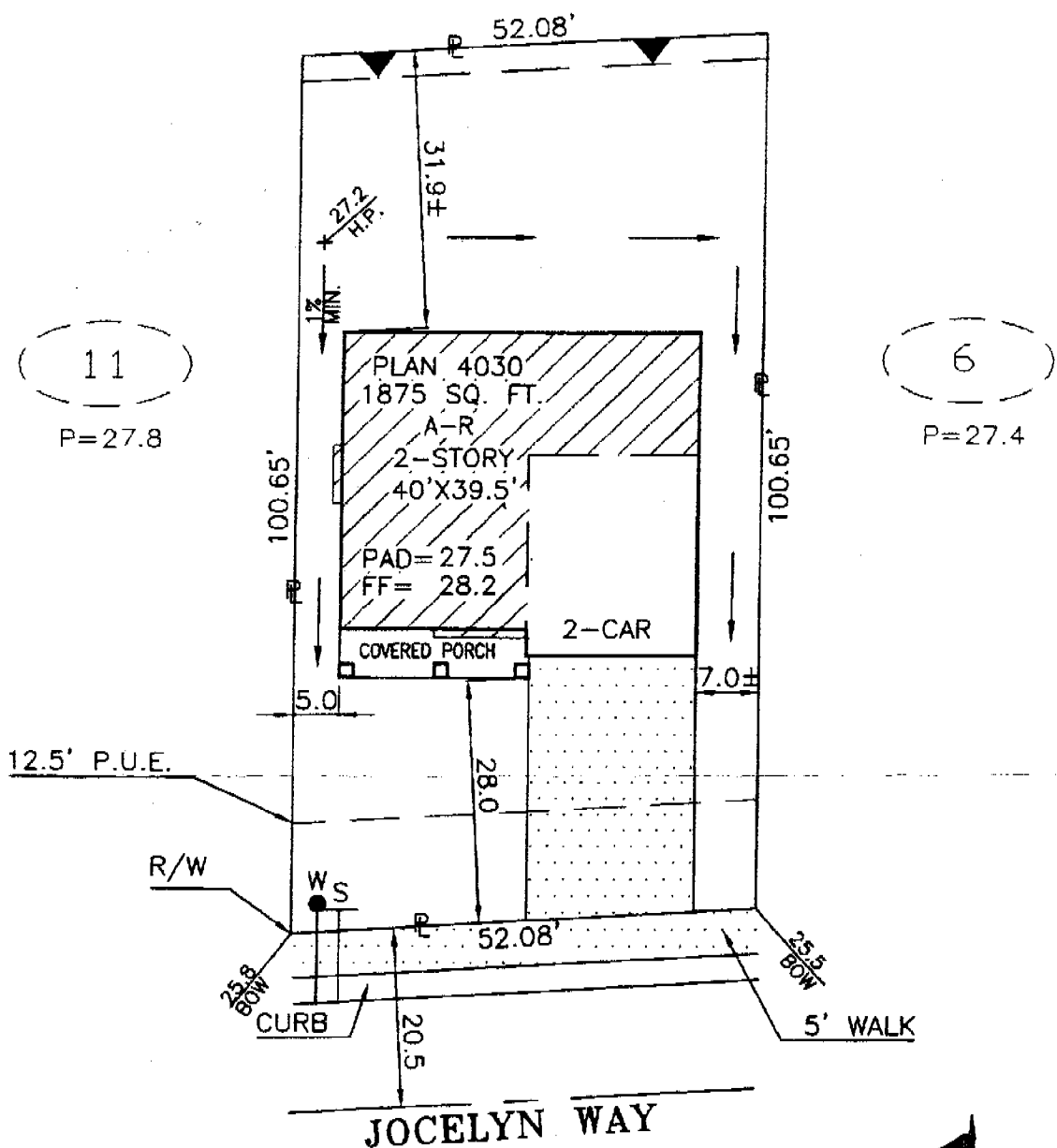

11  
P=27.8

6  
P=27.4

JOCELYN WAY

This set of plans and specifications must be kept on the job at all times and it is understood that no changes or alterations from the same without written permission from the Building Inspection Division.



DIMENSIONS SHOWN ARE APPROXIMATE EXCEPT FOR MINIMUMS REQUIRED BY ORDINANCE. THIS PLOT DOES NOT REFLECT AS BUILT CONDITIONS AND MAY VARY FROM THIS PLAN.

<b>WOODSIDE HOMES OF CA, INC.</b> 15 PLAZA DRIVE, SUITE 102 FOLSOM, CALIFORNIA 95630 (TEL.) (916) 608-9600 (FAX.) (916) 608-9940		LAGUNA VISTA CITY OF SACRAMENTO SACTO. COUNTY, CALIFORNIA		<b>NOTES:</b> * CURVED LINES ARE CHORD MEASUREMENTS P.U.E. = PUBLIC UTILITY EASEMENT P.L.E. = PRIVATE LANDSCAPE ESMNT. P.E. = PEDESTRIAN ESMNT.	
ADDRESS: 8609 JOCELYN WAY		LOT COVERAGE: 27.1%			
PLAN NO.: 4030-A		LOT SQ. FT.: 5,233.8		<b>LOT 10</b>	
DRAWN BY: R.P.		APPROVED BY:			
		DATE: 1/21/04		SCALE: 1"=20'	



Planning and Building Department

Building Division

**CITY OF SACRAMENTO**  
CALIFORNIA

November 7, 2003

**Downtown Permits Center**  
1231 I Street, #200  
Sacramento, CA 95814-2998

**North Permits Center**  
2101 Arena Blvd., Suite 200  
Sacramento, CA 95834

ADDRESS 8609 Jocelyn Way PERMIT NO. 0401496

INSPECTION COMMENTS	PERMIT DOCUMENTS
2/24/04 <i>WMB</i> B-R AP	
2-19-04 AP B10.11 P40 <i>J. McKeown</i>	
3-12-04 AP E67 (27275) <i>Beutels</i>	
3-31-04 <i>CLN</i> B17 <i>WMB</i>	
4-1-04 <i>CLN</i> Shear AP B17 <i>WMB</i>	
4-12-04 B-26-81 AP <i>WMB</i>	
4-19-04 B-14 A.P. <i>WMB</i>	
4-21-04 <i>CLN</i> AP P47 <i>WMB</i>	

FINAL APPROVALS	
BUILDING	<i>[Signature]</i> 05-27-04
ELECTRICAL	
PLUMBING	
MECHANICAL	
FIRE	
SITE	

# KwikKote

No. 200-920119

## Stucco System Installation Card

Job Name: LAGUNA VISTA  
Address: 8609 JOCELYN WAY  
          , CA  
Lot #: 0000010

Stucco System Trade Name: KWIK KOTE  
Stucco System Manufacturer: KWIK KOTE CORP.

ICBO Evaluation Service, Inc.  
Report No. 3607  
Date of Job Completion:

Home Builder: WOODSIDE HOMES  
Address: 111 WOODMERE DRIVE #190  
          FOLSOM, CA

Stucco Contractor: KENYON PLASTERING, INC.  
Address: PO BOX 2077  
          North Highlands, CA

Telephone Number: 916/349-8191

Approved Contractor Number as  
issued by the Stucco Manufacturer: 1001

Card Print Date: 03/19/2004

This is to certify that the stucco system on the building exterior at the above address had been installed in accordance with the evaluation report specified above and the manufacturer's instructions.

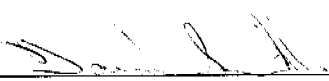
  
\_\_\_\_\_  
Signature of authorized representative of stucco contractor

\_\_\_\_\_  
Date

**INSULATION CERTIFICATE**

THIS IS TO CERTIFY THAT INSULATION HAS BEEN INSTALLED IN CONFORMANCE WITH THE CURRENT ENERGY REGULATIONS, CALIFORNIA ADMINISTRATION CODE, TITLE 24, STATE OF CALIFORNIA, IN THE BUILDING LOCATED AT:

SITE ADDRESS LOT 10 LAGUNA VISTA SACRAMENTO CA  
NUMBER CITY STATE

**CEILING:**

BLOW: MANUFACTURER KNAUF THICKNESS N/A RVALUE N/A  
SQUARE FEET \_\_\_\_\_ #BAGS/LBS PER BAGS \_\_\_\_\_

BATTS: MANUFACTURER JOHNS MANVILLE THICKNESS 13" 38  
JOHNS MANVILLE \_\_\_\_\_

**EXTERIOR WALLS:**

MANUFACTURER JOHNS MANVILLE THICKNESS 3.5" RVALUE 13  
JOHNS MANVILLE \_\_\_\_\_

**FLOOR INSULATION:**

MANUFACTURER JOHNS MANVILLE THICKNESS N/A RVALUE N/A  
JOHNS MANVILLE \_\_\_\_\_

**AIR INFILTRATION:** (TITLE 24)  
YES XXX NO \_\_\_\_\_

OTHER: \_\_\_\_\_  
\_\_\_\_\_

GENERAL CONTRACTOR: WOODSIDE HOMES LICENSE # \_\_\_\_\_

BY: \_\_\_\_\_ TITLE \_\_\_\_\_ DATE \_\_\_\_\_

INSULATION CONTRACTOR: WESTERN INSULATION LP LICENSE # 794484

BY: Becky Guthrie TITLE AUTH. AGENT DATE 4/16/04  
BECKY GUTHER