

**CITY OF SACRAMENTO**

1231 I Street, Sacramento, CA 95814

**Permit No: 0404308**

**Insp Area: 1**

Thos Bros: 297E3

**Site Address: 1903 F ST SAC**

Parcel No: 003-0124-018

Sub-Type: NOTHR

Housing (Y/N): N

CONTRACTOR

OWNER

WIRTH SEAN P & CYNTHIA GARCIA  
2848 4TH AVE  
SACRAMENTO CA 95818

ARCHITECT

**Nature of Work: 5 METER ELECTRICAL SERVICE CHANGE OUT**

**CONSTRUCTION LENDING AGENCY:** I hereby affirm under penalty of perjury that there is a construction lending agency for the performance of the work for which this permit is issued (Sec. 3097, Civ. C).

Lender's Name \_\_\_\_\_ Lender's Address \_\_\_\_\_

**LICENSED CONTRACTORS DECLARATION:** I hereby affirm under penalty of perjury that I am licensed under provisions of Chapter 9 (commencing with section 7000) of Division 3 of the Business and Professions Code and my license is in full force and effect.

License Class \_\_\_\_\_ License Number \_\_\_\_\_ Date \_\_\_\_\_ Contractor Signature \_\_\_\_\_

**OWNER-BUILDER DECLARATION:** I hereby affirm under penalty of perjury that I am exempt from the contractors License Law for the following reason (Sec. 7031.5, Business and Professions Code; any city or county which requires a permit to construct, alter, improve, demolish, or repair any structure, prior to its issuance, also requires the applicant for such permit to file a signed statement that he or she is licensed pursuant to the provisions of the Contractors License Law (Chapter 9 (commencing with Section 7000) of Division 8 of the Business and Professions Code) or that he or she is exempt therefrom and the basis for the alleged exemption. Any violation of Section 7031.5 by any applicant for a permit subjects the applicant to a civil penalty of not more than five hundred dollars (\$500.00);

I, as a owner of the property, or my employees with wages as their sole compensation, will do the work, and the structure is not intended or offered for sale (Sec. 7044, Business and Professional Code: The Contractors License Law does not apply to an owner of property who builds or improves thereon, and who does such work himself or herself or through his/her own employees, provided that such improvements are not intended or offered for sale. If, however, the building or improvement is sold within one year of completion, the owner-builder will have the burden of proving that he/she did not build or improve for the purpose of sale.)

I, as owner of the property, am exclusively contracting with licensed contractors to construct the project (Sec. 7044, Business and Professions Code: The Contractors License Law does not apply to an owner of property who builds or improves thereon, and who contracts for such projects with a contractor(s) licensed pursuant to the Contractors License Law).

I am exempt under Sec. \_\_\_\_\_ B & PC for this reason: \_\_\_\_\_

Date 3-23-04 Owner Signature Sean Wirth

**IN ISSUING THIS BUILDING PERMIT,** the applicant represents, and the city relies on the representation of the applicant, that the applicant verified all measurements and locations shown on the application or accompanying drawings and that the improvement to be constructed does not violate any law or private agreement relating to permissible or prohibited locations for such improvements. This building permit does not authorize any illegal location of any improvement or the violation of any private agreement relating to location of improvements.

I certify that I have read this application and state that all information is correct. I agree to comply with all city and county ordinances and state laws relating to building construction and hereby authorize representative(s) of this city to enter upon the above-mentioned property for inspection purposes.

Date 3-23-04 Applicant/Agent Signature Sean Wirth

**WORKER'S COMPENSATION DECLARATION:** I hereby affirm under penalty of perjury one of the following declarations:  
 I have and will maintain a certificate of consent to self-insure for workers' compensation as provided for by Section 3700 of the Labor Code, for the performance of work for which the permit is issued.

I have and will maintain workers' compensation insurance, as required by Section 3700 of the Labor Code, for the performance of the work for which this permit is issued. My workers' compensation insurance carrier and policy number are:

Carrier \_\_\_\_\_ Policy Number \_\_\_\_\_ Exp Date \_\_\_\_\_

(This section need not be completed if the permit is for \$100 or less) I certify that in the performance of the work for which this permit is issued, I shall not employ any person in any manner so as to become subject to the workers' compensation laws of California and agree that if I should become subject to the workers' compensation provisions of Section 3700 of the Labor Code, I shall forthwith comply with those provisions.

Date 3-23-04 Applicant Signature Sean Wirth

**WARNING: FAILURE TO SECURE WORKER'S COMPENSATION COVERAGE IS UNLAWFUL AND SHALL SUBJECT AN EMPLOYER TO CRIMINAL PENALTIES AND CIVIL FINES UP TO ONE HUNDRED THOUSAND DOLLARS (\$100,000) IN ADDITION TO THE COST OF COMPENSATION, DAMAGES AS PROVIDED FOR IN SECTION 3706 OF THE LABOR CODE, INTEREST AND ATTORNEY'S FEE.**

**THIS PERMIT SHALL EXPIRE BY LIMITATION IF WORK IS NOT COMMENCED WITHIN 180 DAYS.**

# APPLICATION FOR COMMERCIAL BUILDING PERMIT

**CITY OF SACRAMENTO**  
**PLANNING & BUILDING DEPARTMENT**  
 1231 I Street, Suite 200 or 2101 Arena Bl., 200  
 Sacramento, CA 95814 Sacramento, CA 95834  
 (916) 264-5656, 1-866 EZ PERMIT or www.cityofsacramento.org

|                   |                   |
|-------------------|-------------------|
| <b>ACTIVITY #</b> | <b>Insp. Area</b> |
|-------------------|-------------------|

*Applicant to complete all areas down to valuation*

**ADDRESS** 1903 -1905 F Street Suite \_\_\_\_\_  
**PARCEL #** 003 0124 -018

|   |  |
|---|--|
| <p style="text-align: center;"><b>CONTACT</b></p> <p>Name <u>Sean Wirth</u><br/>                 Street Address <u>2848 4th Avenue</u><br/>                 City/State/Zip <u>Sacramento CA 95818</u><br/>                 Phone <u>451-6872</u> FAX <u>same</u><br/>                 E-mail: <u>gar.wir@ardennet.com</u></p> | <p style="text-align: center;"><b>LICENSED CONTRACTOR</b> Lic No. # _____</p> <p>Name _____<br/>                 Address _____<br/>                 City/State/Zip _____<br/>                 Phone _____ FAX _____<br/>                 E-mail: _____</p> |
| <p style="text-align: center;"><b>ARCHITECT/ENGINEER</b></p> <p>Name _____<br/>                 Address _____<br/>                 City/State/Zip _____<br/>                 Phone _____ FAX _____<br/>                 E-mail: _____</p>   | <p style="text-align: center;"><b>OWNER</b></p> <p>Name <u>SAME</u><br/>                 Address _____<br/>                 City/State/Zip _____<br/>                 Phone _____ FAX _____<br/>                 E-mail: _____</p>                         |

→ Will permittee have any employees on the jobsite?  No  Yes → **INSURANCE CO:** \_\_\_\_\_  
 → **WORKER'S COMPENSATION POLICY #** \_\_\_\_\_ **EXPIRATION DATE:** \_\_\_\_\_

**NATURE OF WORK IN DETAIL:** New 5 meter electrical service

**OCCUPANT/TENANT:** \_\_\_\_\_ **VALUATION:** \$ 2,500.00

|                               |                           |            |             |            |             |  |              |                 |             |                  |             |  |             |  |
|-------------------------------|---------------------------|------------|-------------|------------|-------------|--|--------------|-----------------|-------------|------------------|-------------|--|-------------|--|
| <b>FLOOD STATUS</b>           |                           |            |             |            |             | <b>S.C.A.T.</b>  |              |                 |             |                  |             |  |             |  |
| <b>JOB DESCRIPTION</b>        |                           |            |             |            |             | BLDG <input type="checkbox"/> SHELL <input type="checkbox"/> APT <input type="checkbox"/> TI ( ) <input type="checkbox"/> REM ( ) <input type="checkbox"/> SW <input type="checkbox"/> FIRE <input type="checkbox"/> ADD <input type="checkbox"/> OTHER <input type="checkbox"/> |              |                 |             |                  |             |  |             |  |
| <b>INSPECTION DISCIPLINES</b> |                           |            | <b>BLDG</b> |            | <b>MECH</b> |  | <b>PLUMB</b> |                 | <b>ELEC</b> |                  | <b>SITE</b> |  | <b>FIRE</b> |  |
| # Stories                     | 1 <sup>st</sup> flr Area. | Total Area | Use Zone    | Occp Group | Const type  | <b>Fire Req. Y / N</b>   |              | <b>Fed Code</b> |             | <b>Vio. File</b> |             |  |             |  |
| B                             | L                         | P          | M           | E          | F           | SPR ALARM  |              | S D             |             | PW               | UTIL        |  |             |  |
| 2                             | 21500                     | 22900      |             |            |             |  |              |                 |             |                  |             |  |             |  |

**COMMENTS:**

**REGIONAL SANITATION FEES?**  Yes  No      **HEALTH DEPARTMENT?**  Yes  No  
**WATER FLOW TEST FOR NEW BUILDINGS OR ADDITIONS?**  Yes  No

SMUD  
 ○ 2" weatherhead (E)  
 2" RES Riser (E)  
 ○ NEW (3) 4/0 CU

1903 F Street  
 Sec, Ca

ISSUED

MAR 28 2004

Sacramento Building Division

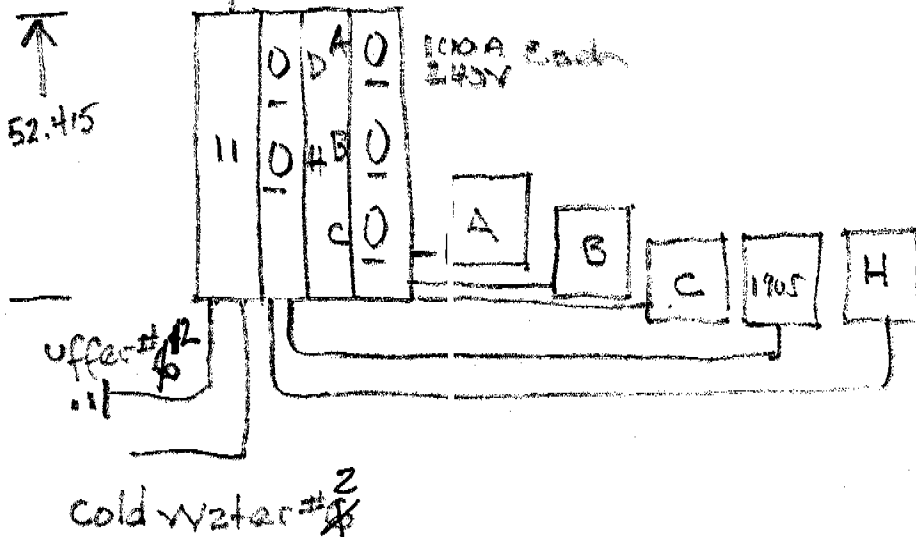
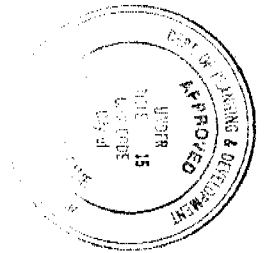

This set of plans and specifications must be kept on the job at all times and it is unlawful to make any changes or alterations from the same without written permission from the Building Inspection Division. The approval of all permits and specifications shall be the responsibility of the contractor. Violation of any code provisions shall be the responsibility of the contractor.

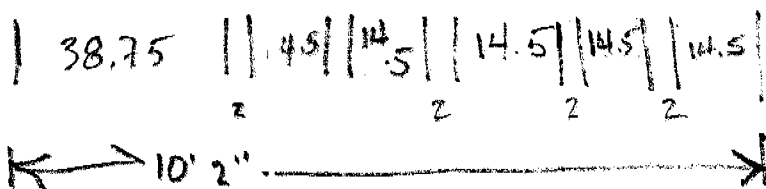

Scale  
 1/8" = 12"

## FILE COPY

1903 F Street  
 Sec, C2 95814  
 HOUSE

Panel Schedule A, B, C, & 1905

| 125A 120/240V Bussing |          |          |        | Raintight    |   |           |            |
|-----------------------|----------|----------|--------|--------------|---|-----------|------------|
| Apt. MAIN Lug Only    |          |          |        | House Panel. |   |           |            |
| 1                     | Kit plug | CB 20    | CB 20  | 2            | 1 | WP EFI 20 | 20 Lites   |
|                       |          | 1500/500 | 500/20 |              |   | 1000/500  |            |
| 3                     | Kit plug | 20       | 20     | 4            | 3 |           |            |
|                       |          | 1500/500 | 500/20 |              |   | 2500      | 30 Hot H2O |
| 5                     | lights   | 20       | 20     | 6            | 5 | 2500      | 30 Hot H2O |
|                       |          | 500/1500 | 500/20 |              |   |           |            |
| 7                     |          |          |        | 8            | 7 |           |            |

$$3500 + 4500 = 8,000$$

$$\times 4$$

$$1000 + 5500$$

LOAD  
 Calc

$$\begin{array}{r} 32,000 \\ 6,500 \\ \hline 3,125 \end{array}$$

+ 1.25 largest load

$$416.25 - 240 = 173.43 \text{ AMP}$$

ISSUED

MAR 23 2004

Sacramento Building Division

5

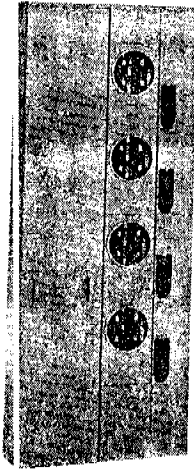

Meter Pack

- 1MP units are self-contained (main terminal box included) for installations requiring up to six meter socket positions in a single enclosure.
- Units are not gangable with any other metering device.
- Approved by major power companies, UL listed, suitable as service equipment and meets the service and electrical requirements of EUSERC and CECHA.
- Series rating up to 100,000 AIC.
- All ringless cover devices include fifth jaw as standard.
- Ring type devices do not include fifth jaw as standard. Order 1MM5JK if needed.
- Bondable neutral.
- 120/240V AC, 1-phase 3-wire metering device.
- Up to 600A maximum bus rating.
- Incoming lugs not included (A, phase B, and neutral)
- Indoor/outdoor construction.
- Provision for 2-pole breaker (plug-on type for 125A socket bolt-on type for 200A socket circuit breakers not included)
- Underground incoming feed
- For overhead feed, use DS hubs to ensure proper socket bussing and then loop lugs enter the line lugs.
- 1MP2122R, RRL and RR DS Type hub.
- Aluminum or copper bus.

Product Selection

Table 5-1. Meter Pack Catalog Numbering System

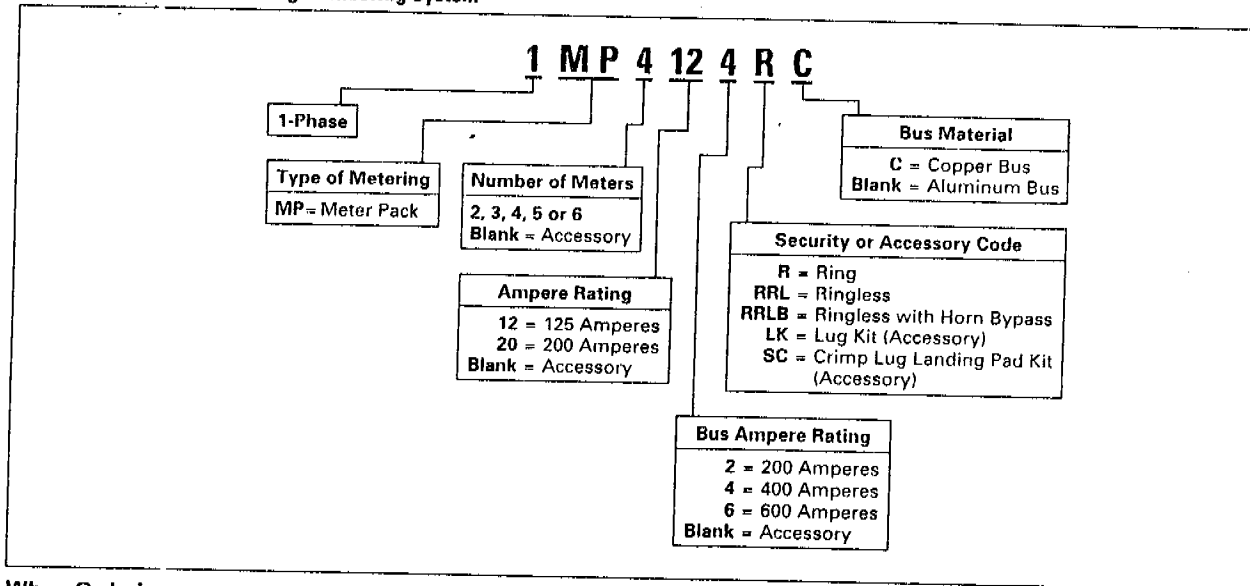

When Ordering:

1. Determine catalog number of the basic device.
2. Include Lug Kit for incoming section. See Table 5-4.
3. Find quantity and catalog numbers for tenant circuit breakers. (Order one breaker per socket.) See Page 5-7.
4. Select required accessories. See Pages 5-34 and 5-35.

ISSUED

MAR 23 1994

Sacramento Building Division

Group Metering — Meter Packs

Dimensions and Knockouts (in Inches) -- 1MP Meter Packs — Aluminum and Copper Bus

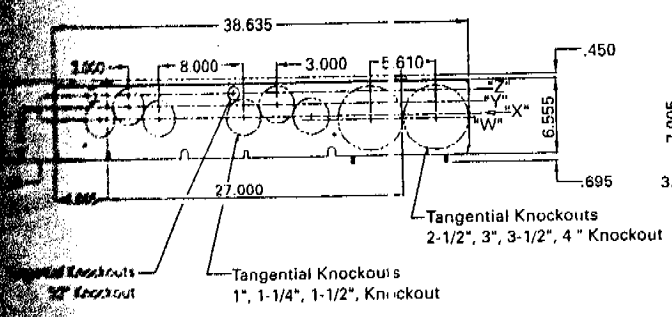

5 & 6 Meter Endwall

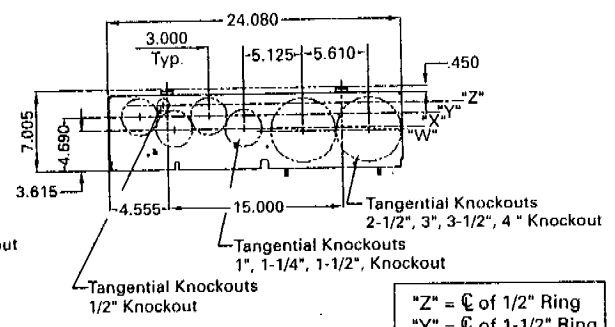

2 & 4 Meter Endwall

"Z" =  $\phi$  of 1/2" Ring  
"Y" =  $\phi$  of 1-1/2" Ring  
"X" =  $\phi$  of 1-1/2" Ring  
"W" =  $\phi$  of 4" Ring

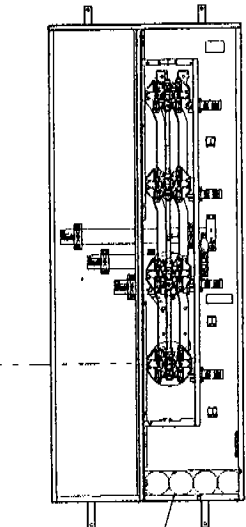
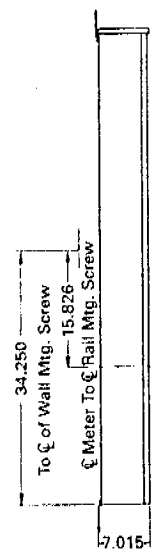

3, 4 Meter Device

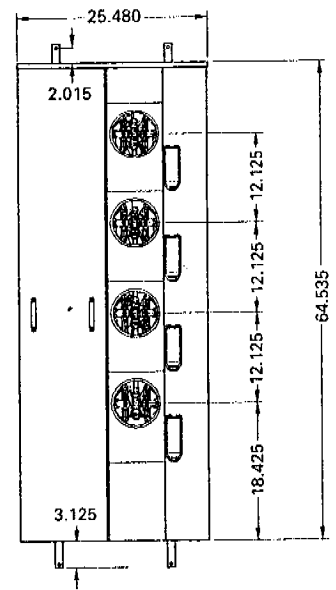

ISSUED

MAR 23 2004

Sacramento Building Division

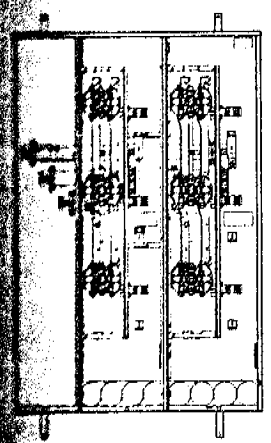

5, 6 Meter Device

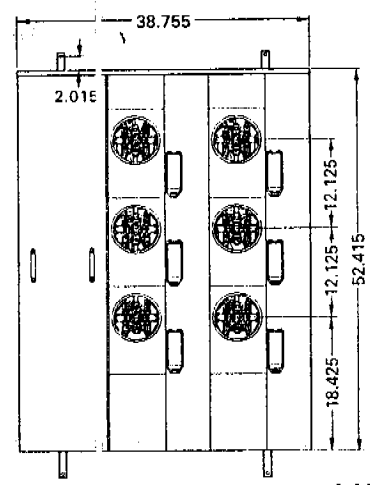

200A Meter Packs

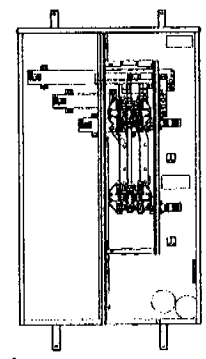

2 Meter Device

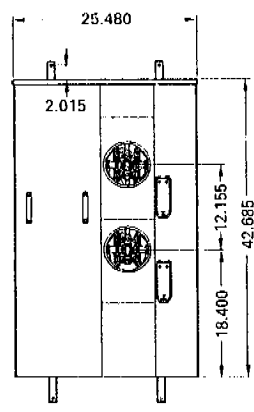

200A Maximum Tenant Breaker

Group Metering — Meter Packs

Product Selection

Meter Packs

Ring Aluminum Bus

| Number of Meter Sockets | Bus Ampacity | Main Tenant Breaker Type See Table 5-6 | Catalog Number | Price U.S. \$ | Semi-flush Flange Kit Catalog Number | Price U.S. \$ |
|-------------------------|--------------|--|----------------|---------------|--------------------------------------|---------------|
|-------------------------|--------------|--|----------------|---------------|--------------------------------------|---------------|

Ring Meter Socket Covers

|          |          |     |                     |                       |          |          |         |
|----------|----------|-----|---------------------|-----------------------|----------|----------|---------|
| 125<br>A | 2        | 200 | Plug-on Type<br>BR_ | 1MP2122R (2)          | 745.00   | 1MPSFK1  | 65.50   |
|          | 3        | 400 | BRH_                | 1MP3124R              | 825.00   | 1MPSFK2  | 73.50   |
|          | 4        | 400 | BRH_                | 1MP4124R              | 1,150.00 | 1MPSFK2  | 73.50   |
|          | 5        | 600 | BRHH_               | 1MP5126R              | 1,445.00 | 1MPSFK3  | 65.50   |
|          | 6        | 600 | —                   | 1MP6126R              | 1,675.00 | 1MPSFK3  | 65.50   |
|          | 200<br>A | 2   | 400                 | Bolt-on Type<br>CC2_X | 1MP2204R | 1,020.00 | 1MPSFK4 |
| 3        |          | 600 | CHH2_H2X            | 1MP3206R              | 1,220.00 | 1MPSFK5  | 98.00   |
| 4        |          | 600 | CHH2_H4X            | 1MP4206R              | 1,630.00 | 1MPSFK5  | 98.00   |
| 5        |          | 600 | CHH2_H4X            | 1MP5206R              | 2,040.00 | 1MPSFK6  | 68.00   |
| 6        |          | 600 | CHH_X               | 1MP6206R              | 2,440.00 | 1MPSFK6  | 68.00   |

Ring Style Meter Socket Covers

|   |   |     |                     |                       |            |          |         |
|---|---|-----|---------------------|-----------------------|------------|----------|---------|
|   | 2 | 200 | Plug-on Type<br>BR_ | 1MP2122RRL (2)        | 745.00     | 1MPSFK1  | 65.50   |
|   | 3 | 400 | BRH_                | 1MP3124RRL            | 825.00     | 1MPSFK2  | 73.50   |
|   | 4 | 400 | BRH_                | 1MP4124RRL            | 1,150.00   | 1MPSFK2  | 73.50   |
|   | 5 | 600 | BRHH_               | 1MP5126RRL            | 1,445.00   | 1MPSFK3  | 65.50   |
|   | 6 | 600 | —                   | 1MP6126RRL            | 1,675.00   | 1MPSFK3  | 65.50   |
|   |   | 2   | 400                 | Bolt-on Type<br>CC2_X | 1MP2204RRL | 1,020.00 | 1MPSFK4 |
| 3 |   | 600 | CHH2_H2X            | 1MP3206RRL            | 1,220.00   | 1MPSFK5  | 98.00   |
| 4 |   | 600 | CHH2_H4X            | 1MP4206RRL            | 1,630.00   | 1MPSFK5  | 98.00   |
| 5 |   | 600 | CHH2_H4X            | 1MP5206RRL            | 2,040.00   | 1MPSFK6  | 68.00   |
| 6 |   | 600 | CHH_X               | 1MP6206RRL            | 2,440.00   | 1MPSFK6  | 68.00   |

Ring Style Covers with Horn Bypass

|   |   |     |                     |                       |             |          |         |
|---|---|-----|---------------------|-----------------------|-------------|----------|---------|
|   | 2 | 200 | Plug-on Type<br>BR_ | 1MP2122RRLB (2)       | 900.00      | 1MPSFK1  | 65.50   |
|   | 3 | 400 | BRH_                | 1MP3124RRLB           | 1,055.00    | 1MPSFK2  | 73.50   |
|   | 4 | 400 | BRH_                | 1MP4124RRLB           | 1,455.00    | 1MPSFK2  | 73.50   |
|   | 5 | 600 | BRHH_               | 1MP5126RRLB           | 1,815.00    | 1MPSFK3  | 65.50   |
|   | 6 | 600 | —                   | 1MP6126RRLB           | 2,125.00    | 1MPSFK3  | 65.50   |
|   |   | 2   | 400                 | Bolt-on Type<br>CC2_X | 1MP2204RRLB | 1,175.00 | 1MPSFK4 |
| 3 |   | 600 | CHH2_H2X            | 1MP3206RRLB           | 1,450.00    | 1MPSFK5  | 98.00   |
| 4 |   | 600 | CHH2_H4X            | 1MP4206RRLB           | 1,925.00    | 1MPSFK5  | 98.00   |
| 5 |   | 600 | CHH2_H4X            | 1MP5206RRLB           | 2,425.00    | 1MPSFK6  | 68.00   |
| 6 |   | 600 | CHH_X               | 1MP6206RRLB           | 2,890.00    | 1MPSFK6  | 68.00   |

Ring Style Meter Packs do not come with fifth jaw. Order 1MM5KJ if needed.

Bus lugs included. #6 - 300 kcmil. (Optional lug are not available.)

With jaw factory installed at 9 o'clock position.

Change in field from ring to ringless — order MMRC125.

Change in field from ring to ringless — order MMRC200.

Change from ring to ringless covers, the top socket only in 2, 5 and 6 socket designs — order 1MMRC125T. Top socket only — other sockets see

See Table 5-4 for Main Lug Kit Selection.

See Table 5-5 for Wire Sizes.

5

ISSUED

MAR 28 2005

Sacramento Building Division

Discount Symbol ..... 22-CD