

**CITY OF SACRAMENTO**  
1231 I Street, Sacramento, CA 95814

**Permit No: 0611387**  
**Insp Area: 3**  
**Thos Bros: 317F2**

**Site Address: 3941 34TH ST SAC**  
Parcel No: 020-0052-019 34TH ST

**Sub-Type: NSFR**  
**Housing (Y/N): N**

**CONTRACTOR**  
MELNIKOV CONSTRUCTION, INC  
5929 SHIRLEY AV  
SACRAMENTO CA 95608

**OWNER**  
TOM ARMSTRONG & MELNIKOV CONST  
5929 SHIRLEY AV  
CARMICHAEL, CA 95608

**ARCHITECT**

**Nature of Work: NEW SFR 1642 SQ FT LIVING SPACE, 265 SQ FT GARAGE, 87.5 SQ FT PORCH--IN DESIGN REVIEW AREA--**

**CONSTRUCTION LENDING AGENCY:** I hereby affirm under penalty of perjury that there is a construction lending agency for the performance of the work for which this permit is issued (Sec. 3097, Civ. C).

Lender's Name \_\_\_\_\_ Lender's Address \_\_\_\_\_

**LICENSED CONTRACTORS DECLARATION:** I hereby affirm under penalty of perjury that I am licensed under provisions of Chapter 9 (commencing with section 7000) of Division 3 of the Business and Professions Code and my license is in full force and effect.

License Class \_\_\_\_\_ License Number 724336 Date \_\_\_\_\_ Contractor Signature \_\_\_\_\_

**OWNER-BUILDER DECLARATION:** I hereby affirm under penalty of perjury that I am exempt from the contractors License Law for the following reason (Sec. 7031.5, Business and Professions Code; any city or county which requires a permit to construct, alter, improve, demolish, or repair any structure, prior to its issuance, also requires the applicant for such permit to file a signed statement that he or she is licensed pursuant to the provisions of the Contractors License Law (Chapter 9 (commencing with Section 7000) of Division 8 of the Business and Professions Code) or that he or she is exempt therefrom and the basis for the alleged exemption. Any violation of Section 7031.5 by any applicant for a permit subjects the applicant to a civil penalty of not more than five hundred dollars (\$500.00);

I, as a owner of the property, or my employees with wages as their sole compensation, will do the work, and the structure is not intended or offered for sale (Sec. 7044, Business and Professional Code: The Contractors License Law does not apply to an owner of property who builds or improves thereon, and who does such work himself or herself or through his/her own employees, provided that such improvements are not intended or offered for sale. If, however, the building or improvement is sold within one year of completion, the owner-builder will have the burden of proving that he/she did not build or improve for the purpose of sale.)

I, as owner of the property, am exclusively contracting with licensed contractors to construct the project (Sec. 7044, Business and Professions Code: The Contractors License Law does not apply to an owner of property who builds or improves thereon, and who contracts for such projects with a contractor(s) licensed pursuant to the Contractors License Law).

I am exempt under Sec. \_\_\_\_\_ B & PC for this reason: \_\_\_\_\_  
Date 9/5/06 Owner Signature [Signature]

**IN ISSUING THIS BUILDING PERMIT,** the applicant represents, and the city relies on the representation of the applicant, that the applicant verified all measurements and locations shown on the application or accompanying drawings and that the improvement to be constructed does not violate any law or private agreement relating to permissible or prohibited locations for such improvements. This building permit does not authorize any illegal location of any improvement or the violation of any private agreement relating to location of improvements.

I certify that I have read this application and state that all information is correct. I agree to comply with all city and county ordinances and state laws relating to building construction and hereby authorize representative(s) of this city to enter upon the abovementioned property for inspection purposes.

Date 9/5/06 Applicant/Agent Signature [Signature]

**WORKER'S COMPENSATION DECLARATION:** I hereby affirm under penalty of perjury one of the following declarations:  
 I have and will maintain a certificate of consent to self-insure for workers' compensation as provided for by Section 3700 of the Labor Code, for the performance of work for which the permit is issued.

I have and will maintain workers' compensation insurance, as required by Section 3700 of the Labor Code, for the performance of the work for which this permit is issued. My workers' compensation insurance carrier and policy number are:

Carrier VIRGINIA SURETY COMPANY, INC. Policy Number 00500016151 Exp Date 06/01/2007

(This section need not be completed if the permit is for \$100 or less) I certify that in the performance of the work for which this permit is issued, I shall not employ any person in any manner so as to become subject to the workers' compensation laws of California and agree that if I should become subject to the workers' compensation provisions of Section 3700 of the Labor Code, I shall forthwith comply with those provisions.

Date 9/5/06 Applicant Signature [Signature]

**WARNING: FAILURE TO SECURE WORKER'S COMPENSATION COVERAGE IS UNLAWFUL AND SHALL SUBJECT AN EMPLOYER TO CRIMINAL PENALTIES AND CIVIL FINES UP TO ONE HUNDRED THOUSAND DOLLARS (\$100,000) IN ADDITION TO THE COST OF COMPENSATION, DAMAGES AS PROVIDED FOR IN SECTION 3706 OF THE LABOR CODE, INTEREST AND ATTORNEY'S FEE.**

**THIS PERMIT SHALL EXPIRE BY LIMITATION IF WORK IS NOT COMMENCED WITHIN 180 DAYS.**

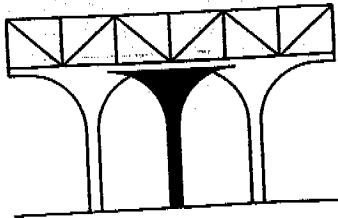

GENE S. PORTER INC.

ENGINEERING  
LIC. # 15182  
8952 NEW DAWN DRIVE  
SACRAMENTO, CA 95826

(916) 362-4363

FAX (916) 362-1715

10/19/06

**COUNTY OF SACTO,  
BUILDING INSPECTION**

RE: 3941 - 34<sup>TH</sup> ST  
Sacto, Calif.  
Permit # 0611387

Attn: *Doug Pierson*  
Inspector

Dear Doug:

*Regarding your 11/13/06 correction notice.*

Item #1 - Coil strap installation to beam. see detail 

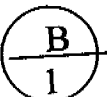
Item #2 - Exterior shear line between 1<sup>ST</sup> & 2<sup>N</sup> Stories. See detail 

Sincerely,

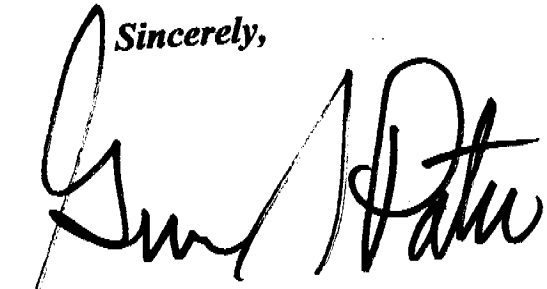

Gene S. Porter  
Engineer.

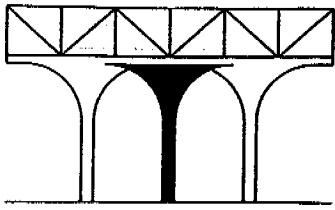

GENE S. PORTER INC.

ENGINEERING  
LIC. # 15182  
8952 NEW DAWN DRIVE  
SACRAMENTO, CA 95826

(916) 362-4363

FAX (916) 362-1715

10/19/06

**COUNTY OF SACTO,  
BUILDING INSPECTION**

RE: 3941 - 34<sup>TH</sup> ST  
Sacto, Calif.  
Permit # 0611387

**Attn: Doug Pierson  
Inspector**

Dear Doug:

*Regarding your 11/13/06 correction notice.*

Item #1 - Coil strap installation to beam. see detail  $\frac{A}{1}$ .

Item #2 - Exterior shear line between 1<sup>ST</sup> & 2<sup>N</sup> Stories. See detail  $\frac{B}{1}$ .

Sincerely,

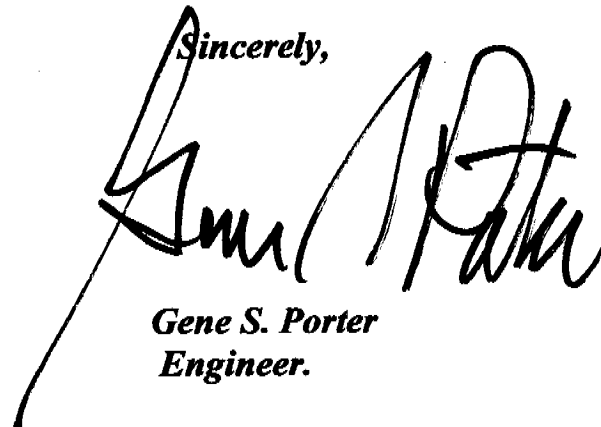

**Gene S. Porter  
Engineer.**

# CORRECTION NOTICE

City of Sacramento  
Building Inspection Division

-----  
When corrections are made  
call 808-7622 for reinspection

Permit #: 0611387  
Job Location: 3941 34TH ST  
SACRAMENTO, CA  
Inspection Requested: 26 Bldg-Shear Nail

Inspection Results: Correction Notice

Inspector this day inspected this structure for the requested inspection and found the following violations of City and/or State laws governing same:

Inspection Comments: 1. Provide engineers fix for coil strap installation from garage strong walls to catalever second floor above.  
2. Exterior shear broken between second floor I-joists and sill plate. Provide engineered fix.  
3. Properly nail sill plate per plan- second floor rear.  
4. Attachment of front porch overhang roof srtructure shall be to strucual lumber not OSB

Scheduled: 2006-11-13 / 24:57

Inspector: Doug Pierson

Inspector's Phone Number:

804-4718

## Permit Conditions

Condition:	Comment:	Date:
HIST	SET ID "DASHA"	2006-08-16
HIST	WATER IS NOT AVAILABLE TO THIS PARCEL.	2006-08-09

Building  
 Plumbing

Mechanical  
 Electrical

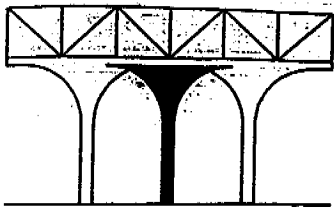

GENE S. PORTER INC.

(916) 362-4363

FAX (916) 362-1715

ENGINEERING  
LIC. # 15182  
8952 NEW DAWN DRIVE  
SACRAMENTO, CA 95826

34<sup>TH</sup> ST. LOT #5  
SACRAMENTO, CALIF.

SHEET

10 OF 2

11/15/06

JOB NO.

CLARIFICATION DETAIL

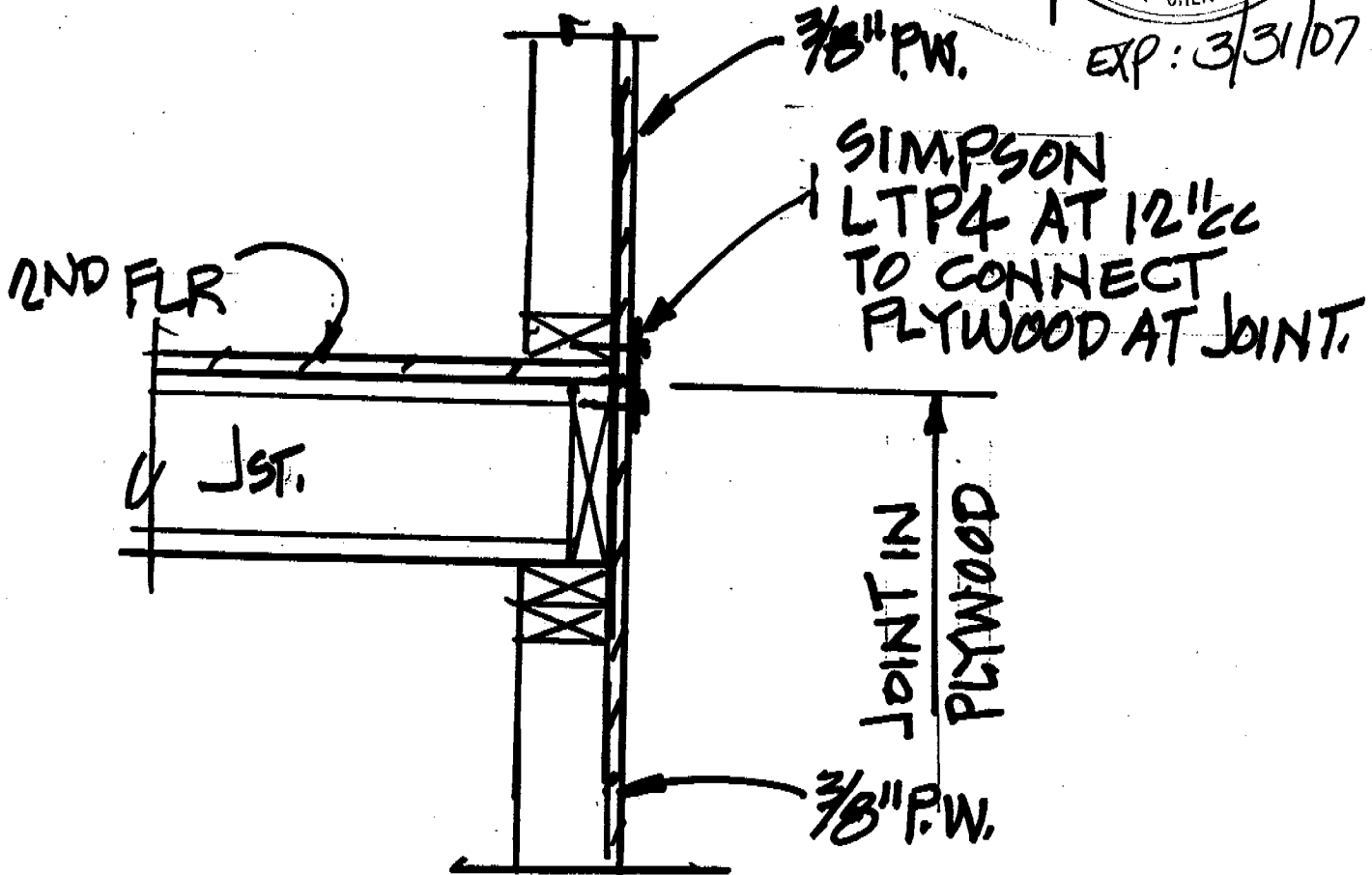
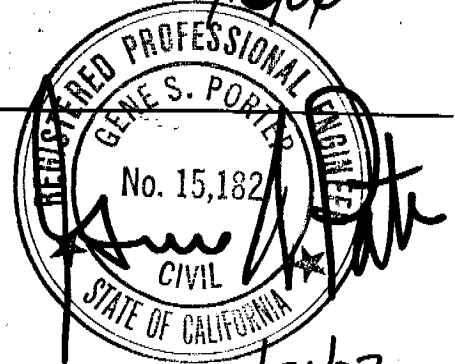

PLYWOOD REPAIR

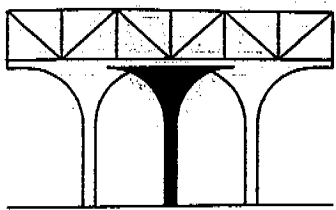

**ENGINEERING**  
 LIC. # 15182  
 8952 NEW DAWN DRIVE  
 SACRAMENTO, CA 95826

GENE S. PORTER INC.

(916) 362-4363

FAX (916) 362-1715

11/15/00

34<sup>TH</sup> ST. LOT #5  
 SACRAMENTO, CALIF.

SHEET **20** OF **2**

JOB NO.

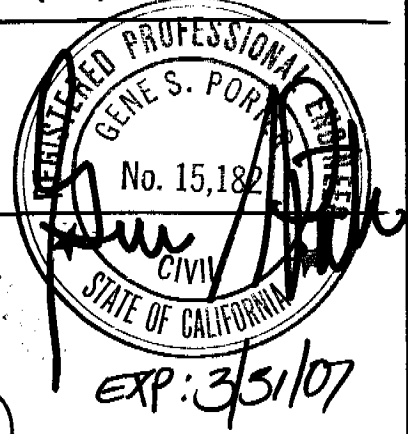

**CLARIFICATION DETAIL**

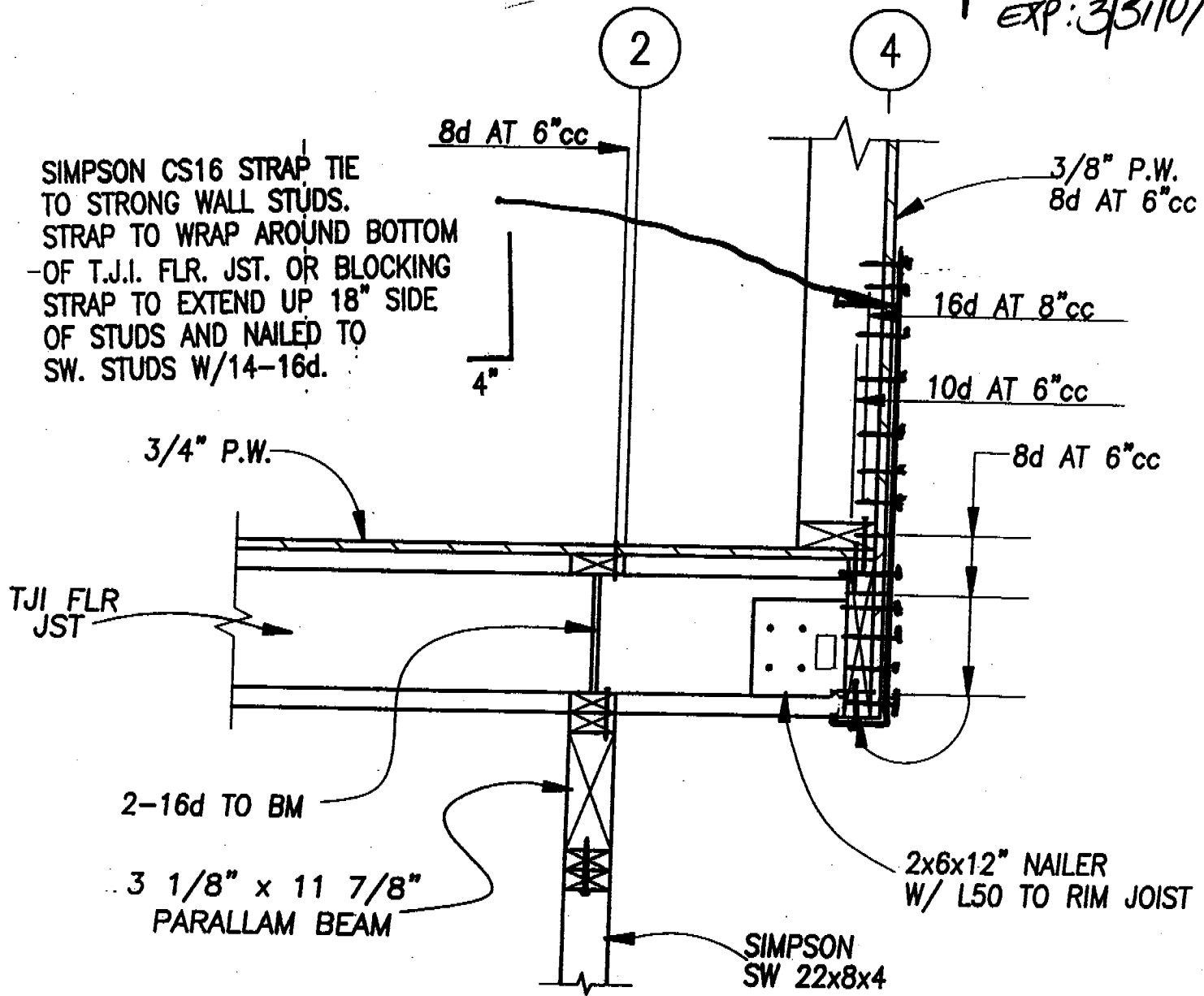

**B**  
**S1**

**SECTION**

1/2" = 1'-0"

VA 02-12-08 AP

B-29/143A/759/E.79

INSTALLATION CERTIFICATE

(Page 1 of 13)

CF-6R

Site Address 3904 ZATA STREET

Permit Number 0611307

An installation certificate is required to be posted at the building site or made available for all appropriate inspections. (The information provided on this form is required; however, use of this form to provide the information is optional.) After completion of final inspection, a copy must be provided to the building department (upon request) and the building owner at occupancy, per Section 10-103(b).

HVAC SYSTEMS:

Heating Equipment

Table with 8 columns: Equip. Type (pkg. heat pump), CEC Certified Mfr Name and Model Number, # of Identical Systems, Efficiency (AFUE, etc.)', Duct Location (attic, etc.), Duct or Piping R-value, Heating Load (Btu/hr), Heating Capacity (Btu/hr). Row 1: CENTRAL AIRSTRIDE FURNACE FINISTROTS 1 97% ATTIC 8.0 75,000 75,000

Cooling Equipment

Table with 8 columns: Equip. Type (pkg. heat pump), CEC Certified Compressor Unit Mfr Name and Model Number, # of Identical Systems, Efficiency (SEER, etc.)', Duct Location (attic, etc.), Duct R-value, Cooling Load (Btu/hr), Cooling Capacity (Btu/hr). Row 1: SPLIT AIR CONDENSER SCURBYL 1 13.0 ATTIC 8.0 42,000 42,000

1. > reads greater than or equal to.

I, the undersigned, verify that equipment listed above is: 1) the actual equipment installed, 2) equivalent to or more efficient than that specified in the certificate of compliance (Form CF-1R) submitted for compliance with the Energy Efficiency Standards for residential buildings, and 3) equipment that meets or exceeds the appropriate requirements for manufactured devices (from the Appliance Efficiency Regulations or Part 6), where applicable.

Signature, Date: Peter Niemi 01/15/08

Installing Subcontractor (Co. Name) OR General Contractor (Co. Name) OR Owner: MELNIKOV CONSTRUCTION, INC.

WATER HEATING SYSTEMS:

Table with 10 columns: Heater Type, CEC Certified Mfr Name & Model Number, Distribution Type (Std. Point-of-Use), If Recirculation, Control Type, # of Identical Systems, Rated Input (kW or Btu/hr), Tank Volume (gallons), Efficiency (EF, RE), Standby Loss (%), External Insulation R-value'. Row 1: SMALL GAS WATER HEATER STANDBY AUTON 1 40000 50 0.62 41A 41A

- 2. For small gas storage (rated input of less than or equal to 75,000 Btu/hr), electric resistance and heat pump water heaters, list Energy Factor. For large gas storage water heaters (rated input of greater than 75,000 Btu/hr), list Recovery Efficiency, Standby Loss and Rated Input. For instantaneous gas water heaters, list Recovery Efficiency and Rated Input. 3. R-12 external insulation is mandatory for storage water heaters with an energy factor of less than 0.58.

Faucets & Shower Heads:

All faucets and showerheads installed are certified to the Commission, pursuant to Title 24, Part 6, Section 111.

I, the undersigned, verify that equipment listed above my signature is: 1) the actual equipment installed, 2) equivalent to or more efficient than that specified in the certificate of compliance (Form CF-1R) submitted for compliance with the Energy Efficiency Standards for residential buildings, and 3) equipment that meets or exceeds the appropriate requirements for manufactured devices (from the Appliance Efficiency Regulations or Part 6), where applicable.

Signature, Date: Peter Niemi 01/15/08

Installing Subcontractor (Co. Name) OR General Contractor (Co. Name) OR Owner: MELNIKOV CONSTRUCTION, INC.

COPY TO: Building Department, IERS Provider (if applicable), Building Owner at Occupancy

BRUCE HOLMES 8/4 2002

**FENESTRATION/GLAZING:**

Manufacturer/Brand Name (GROUP LIKE DOORS/SCREENS)	Product U-Factor (s) CF-1R value <sup>1</sup>	Product SHGC (s) CF-1R value <sup>1</sup>	# of Panels	Total Quantity of Like Product (Optional)	Square Feet	Exterior Shading Device or Overhang	Comments/Location/Special Features
1 JELD-COEN	0.34	0.34	2	2	30.0	BUG SCREEN	FRONT 1st FLOOR
2	0.34	0.34	2	3	33.0	-u-u-	LEFT 1st FL.
3	0.34	0.34	2	2	45.4	-u-u-	REAR 1st FL.
4	0.34	0.34	2	3	38.0	-u-u-	FRONT 2nd FL.
5	0.34	0.34	2	1	3.0	-u-u-	LEFT 2nd FL.
6	0.34	0.34	2	3	45.0	-u-u-	REAR 2nd FL.
7	0.34	0.34	2	3	45.0	-u-u-	RIGHT 2nd FL.
8.							
9.							
10.							
11.							
12.							
13.							
14.							
15.							

<sup>1</sup> Manufactured fenestration products use the values from the product label. Field fabricated fenestration products use the default values from Section 116 of the Energy Efficiency Standards.  
<sup>2</sup> Installed U-Factor must be less than or equal to values from CF-1R. Installed SHGC must be less than or equal to values from CF-1R, or a shading device (exterior or overhang) is installed as specified on the CF-1R. Alternatively, installed weighted average U-Factors for the total fenestration area are less than or equal to values from CF-1R.

I, the undersigned, verify that the fenestration/glazing listed above my signature: 1) is the actual fenestration product installed; 2) is equivalent to or has a lower U-Factor and lower SHGC than that specified in the certificate of compliance (Form CF-1R) submitted for compliance with the Energy Efficiency Standards for residential buildings; and 3) the product meets or exceeds the appropriate requirements for manufactured devices (from Part 6), where applicable.

*[Signature]* 01/08/08 MECISTUO CONSTR., INC.

Item #s (if applicable)	Signature, Date	Installing Subcontractor (Co. Name) OR General Contractor (Co. Name) OR Owner OR Window Distributor

COPY TO: Building Department  
 HERS Provider (if applicable)  
 Building Owner at Occupancy



**INSULATION CERTIFICATE**

THIS IS TO CERTIFY THAT INSULATION HAS BEEN INSTALLED IN CONFORMANCE WITH THE CURRENT ENERGY REGULATIONS, CALIFORNIA ADMINISTRATION CODE, TITLE 24, STATE OF CALIFORNIA, IN THE BUILDING LOCATED AT:

SITE ADDRESS 3941 34TH ST SACRAMENTO CA  
NUMBER CITY STATE

**CEILINGS:**

BLOW: MANUFACTURER GREEN FIBER THICKNESS 10.3" RVALUE 38  
MANUFACTURER GREEN FIBER THICKNESS RVALUE

BATTS: MANUFACTURER KNAUF THICKNESS 13" RVALUE 38  
KNAUF

**EXTERIOR WALLS:**

MANUFACTURER KNAUF THICKNESS 6.25" RVALUE 19  
KNAUF

**FLOOR INSULATION**

MANUFACTURER KNAUF THICKNESS 6.25" RVALUE 19  
KNAUF

**AIR INFILTRATION:** (TITLE 24)  
YES XXX NO

OTHER: \_\_\_\_\_

GENERAL CONTRACTOR: MELNIKOV CONSTRUCTION LICENSE # \_\_\_\_\_

BY: \_\_\_\_\_ TITLE \_\_\_\_\_ DATE \_\_\_\_\_

INSULATION CONTRACTOR: WESTERN INSULATION LP LICENSE # 794484

BY: Becky Gutherz TITLE AUTH. AGENT DATE 5/4/2007  
BECKY GUTHERZ