

CITY OF SACRAMENTO
1231 I Street, Sacramento, CA 95814

Permit No: 0312006

Insp Area: 4

Thos Bros: 277-A4

Site Address: 2838 MYOTIS DR SAC
Parcel No: RYLAND COTTAGES LOT 4

Sub-Type: NSFR

Housing (Y/N): N

CONTRACTOR
RYLAND HOMES
1380 LEAD HILL BLVD. STE 108
ROSEVILLE CA. 95661

OWNER

ARCHITECT

Nature of Work: MP1541 2 STORY 6 ROOM SFR

CONSTRUCTION LENDING AGENCY : I hereby affirm under penalty of perjury that there is a construction lending agency for the performance of the work for which this permit is issued (Sec. 3097, Civ. C).

Lender's Name _____ Lender's Address _____

LICENSED CONTRACTORS DECLARATION: I hereby affirm under penalty of perjury that I am licensed under provisions of Chapter 9 (commencing with section 7000) of Division 3 of the Business and Professions Code and my license is in full force and effect.

License Class B License Number 054648 Date 8.21.03 Contractor Signature [Signature]

OWNER-BUILDER DECLARATION: I hereby affirm under penalty of perjury that I am exempt from the contractors License Law for the following reason (Sec. 7031.5, Business and Professions Code; any city or county which requires a permit to construct, alter, improve, demolish, or repair any structure, prior to its issuance, also requires the applicant for such permit to file a signed statement that he or she is licensed pursuant to the provisions of the Contractors License Law (Chapter 9 (commencing with Section 7000) of Division 8 of the Business and Professions Code) or that he or she is exempt therefrom and the basis for the alleged exemption. Any violation of Section 7031.5 by any applicant for a permit subjects the applicant to a civil penalty of not more than five hundred dollars (\$500.00);

_____, I, as a owner of the property, or my employees with wages as their sole compensation, will do the work, and the structure is not intended or offered for sale (Sec. 7044, Business and Professional Code: The Contractors License Law does not apply to an owner of property who builds or improves thereon, and who does such work himself or herself or through his/her own employees, provided that such improvements are not intended or offered for sale. If, however, the building or improvement is sold within one year of completion, the owner-builder will have the burden of proving that he/she did not build or improve for the purpose of sale.)

_____, I, as owner of the property, am exclusively contracting with licensed contractors to construct the project (Sec. 7044, Business and Professions Code: The Contractors License Law does not apply to an owner of property who builds or improves thereon, and who contracts for such projects with a contractor(s) licensed pursuant to the Contractors License Law).

_____, I am exempt under Sec. _____ B & PC for this reason: _____

Date _____ Owner Signature _____

PAID
SAID PERMIT
AUG 21 2003
NORTH PERMIT CENTER

IN ISSUING THIS BUILDING PERMIT, the applicant represents, and the city relies on the representation of the applicant, that the applicant verified all measurements and locations shown on the application or accompanying drawings and that the improvement to be constructed does not violate any law or private agreement relating to permissible or prohibited locations for such improvements. This building permit does not authorize any illegal location of any improvement or the violation of any private agreement relating to location of improvements.

I certify that I have read this application and state that all information is correct. I agree to comply with all city and county ordinances and state laws relating to building construction and hereby authorize representative(s) of this city to enter upon the above mentioned property for inspection purposes.

Date 8.21.03 Applicant/Agent Signature [Signature]

WORKER'S COMPENSATION DECLARATION: I hereby affirm under penalty of perjury one of the following declarations:

_____, I have and will maintain a certificate of consent to self-insure for workers' compensation as provided for by Section 3700 of the Labor Code, for the performance of work for which the permit is issued.

I have and will maintain workers' compensation insurance, as required by Section 3700 of the Labor Code, for the performance of the work for which this permit is issued. My workers' compensation insurance carrier and policy number are:

Carrier AMERICAN HOME ASSURANCE Policy Number AOS WC7085227 Exp Date 06/01/2003

_____, (This section need not be completed if the permit is for \$100 or less) I certify that in the performance of the work for which this permit is issued, I shall not employ any person in any manner so as to become subject to the workers' compensation laws of California and agree that if I should become subject to the workers' compensation provisions of Section 3700 of the Labor Code, I shall forthwith comply with those provisions.

Date 8.21.03 Applicant Signature [Signature]

WARNING: FAILURE TO SECURE WORKER'S COMPENSATION COVERAGE IS UNLAWFUL AND SHALL SUBJECT AN EMPLOYER TO CRIMINAL PENALTIES AND CIVIL FINES UP TO ONE HUNDRED THOUSAND DOLLARS (\$100,000) IN ADDITION TO THE COST OF COMPENSATION, DAMAGES AS PROVIDED FOR IN SECTION 3706 OF THE LABOR CODE, INTEREST AND ATTORNEY'S FEE.

THIS PERMIT SHALL EXPIRE BY LIMITATION IF WORK IS NOT COMMENCED WITHIN 180 DAYS.

Project Address: 2838 Myotis Dr

Assessor Parcel # _____

Lot Number: 4

Subdivision Ryland Cottages

OWNER INFORMATION:

Legal Property Owner: Ryland Homes Phone#: 788-8633
Owner Address: 3005 DOUGLAS #115 City Roseville State CA Zip 95661

CONTRACTOR INFORMATION:

Contractor: Ryland Homes Lic. # 54648 Phone # 788-8633 Fax 784-9805

PROJECT INFORMATION: PLAN 2 - MP 1541

Land Use Zone RIA Occupancy Group R3 Construction Type VN Fed Code 1A

No. of Stories: 2 No. of Rooms: 6 Street Width: 41'

1st Floor Area 695 2nd Floor Area 896 Basement _____ Roof Material Tile

AREA IN SQUARE FOOT OF:

Dwelling/Living 1541

Garage/Storage _____

Decks/Balconies _____

Carports _____

SCOPE OF WORK: SFD

- Information Above Complete
- Violation Files Checked
- Standard Setbacks
- County Sewer
- AR Flood Waiver Required
- Flood Elevation Certificate Required
- Water Development Infill Area
- Planning Approval
- Design Review Approval
- Special Fee Districts Apply:

~THE FOLLOWING MUST BE PROVIDED IN ORDER TO SUBMIT FOR PERMIT~

- 2 COMPLETE PLOT PLANS, LEGIBLE & DRAWN TO SCALE
- 11 X 17 COPY OF FLOOR PLAN WITH FOLLOWING INFORMATION
 - a) Assessor's Parcel Number
 - b) New Floor Area
 - c) Owners Name
 - d) Project Address

Date: _____ Received by: (staff) _____ Permit # _____

SCALE 1"=20'



This set of plans and specifications must be kept on the job at all times and it is unlawful to make any changes or alterations from the same without written permission from the Building Inspection Division.

The approval of this plan and specification SHALL NOT be held to permit or approve the violation of any City Ordinance or State Law.

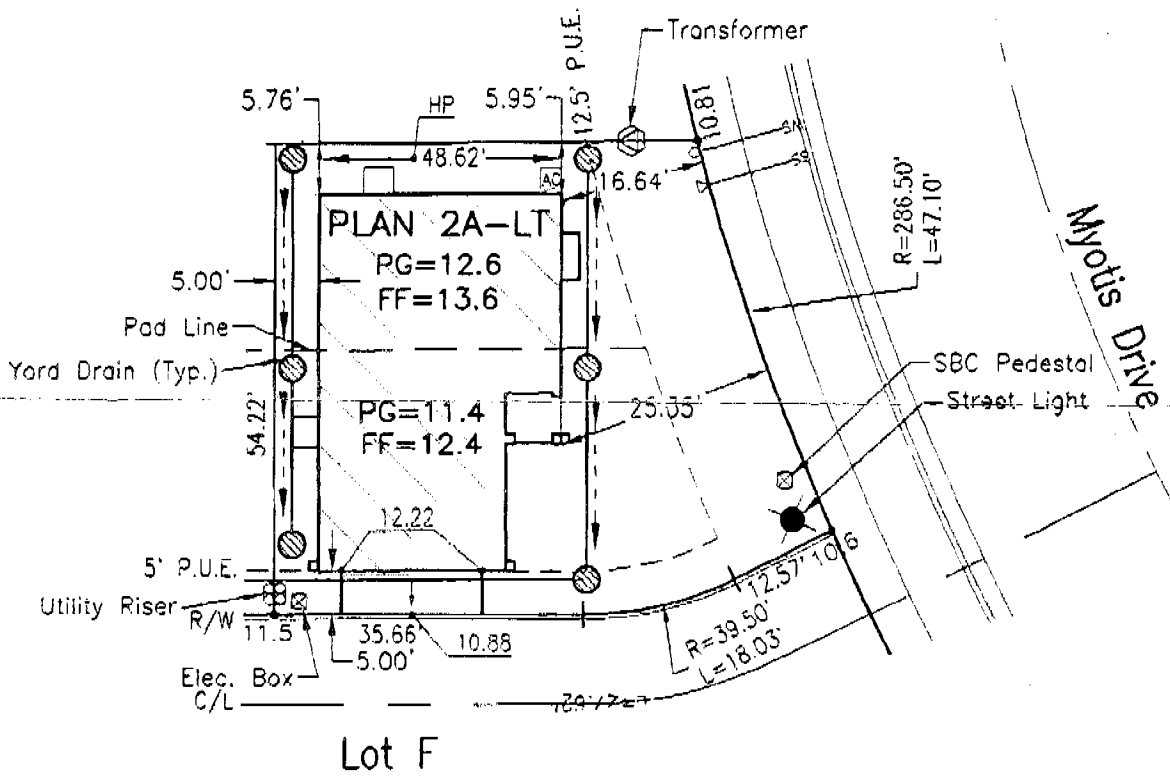

DIMENSIONS SHOWN ARE APPROXIMATE, EXCEPT FOR MINIMUMS REQUIRED BY ORDINANCE. THIS PLOT DOES NOT REFLECT AS-BUILT CONDITIONS WHICH MAY VARY FROM THIS PLAN.

BAKER-WILLIAMS ENGINEERING GROUP 6020 Ryland Drive, Suite 19 Carmichael, California 95608 (916) 331-4336 (Fax) 331-4430	ENGINEERING SURVEYING PLANNING	Ryland Cottages by Ryland Homes Inc.		SCALE : 1"=20' Date: Aug 4, 2003
	PLOT PLAN FOR LOT 4		Address: Lot f City of Sacramento, Sacramento Co.	Lot Area: s.f. Lot Coverage: %
			Drawn By: SAK Job No.: 03-05-051	



Planning and Building Department
 Building Division

CITY OF SACRAMENTO
 CALIFORNIA

Downtown Permits Center
 1231 I Street, #200
 Sacramento, CA 95814-2998

North Permits Center
 2101 Arena Blvd., Suite 200
 Sacramento, CA 95834

ADDRESS 2838 MYOTIS PERMIT NO. 0312006

INSPECTION COMMENTS	PERMIT DOCUMENTS
1-16-04 CN Hef	
1-20-04 APPROVED Hef	Invol Cert. by western Insulation LP 11-20-03

FINAL APPROVALS	
BUILDING	/ Hef 1-20-04
ELECTRICAL	
PLUMBING	
MECHANICAL	
FIRE	
SITE	

INSULATION CERTIFICATE

THIS IS TO CERTIFY THAT INSULATION HAS BEEN INSTALLED IN CONFORMANCE WITH THE CURRENT ENERGY REGULATIONS, CALIFORNIA ADMINISTRATION CODE, TITLE 24, STATE OF CALIFORNIA, IN THE BUILDING LOCATED AT:

SITE ADDRESS LOT 4 COTTAGES LAS CASITAS SACRAMENTO CA
NUMBER CITY STATE

CEILINGS:

BLOW: MANUFACTURER GREEN FIBER THICKNESS N/A R/VALUE N/A
SQUARE FEET _____ #BAGS/LBS PER BAGS _____

BATTS: MANUFACTURER JOHNS MANVILLE THICKNESS 10.25" R/VALUE 30
JOHNS MANVILLE _____

EXTERIOR WALLS:

MANUFACTURER JOHNS MANVILLE THICKNESS 3.5" R/VALUE 13
JOHNS MANVILLE _____

FLOOR INSULATION:

MANUFACTURER JOHNS MANVILLE THICKNESS 3.5" R/VALUE 13
JOHNS MANVILLE _____

AIR INFILTRATION: (TITLE 24)

YES XXX NO _____

OTHER: _____

GENERAL CONTRACTOR: RYLAND HOMES LICENSE # _____

BY: _____ TITLE _____ DATE _____

INSULATION CONTRACTOR: WESTERN INSULATION LP LICENSE # 794484

BY: Becky Guthrie TITLE AUTH. AGENT DATE 11/20/03
BECKY GUTHRIE