

**CITY OF SACRAMENTO**  
1231 I Street, Sacramento, CA 95814

**Permit No: 0013965**

**Insp Area: 4**

**Site Address: 22 CLOE CT SAC**  
Parcel No: 225-1140-012

**Sub-Type: NOTHR**  
**Housing (Y/N): N**

**CONTRACTOR**  
PETKUS BROS  
3068 SUNRISE BL  
RANCHO CORDOVA CA

**OWNER**  
LAURIE CONATY  
22 CLOE CT  
SACRAMENTO CA 95825

**ARCHITECT**

**Nature of Work: PATIO COVER 416 SQ**

**CONSTRUCTION LENDING AGENCY:** I hereby affirm under penalty of perjury that there is a construction lending agency for the performance of the work for which this permit is issued (Sec. 3097, Civ. C).

Lender's Name \_\_\_\_\_ Lender's Address \_\_\_\_\_

**LICENSED CONTRACTORS DECLARATION:** I hereby affirm under penalty of perjury that I am licensed under provisions of Chapter 9 (commencing with section 7000) of Division 3 of the Business and Professions Code and my license is in full force and effect.

License Class B License Number 670242 Date 11-21-00 Contractor Signature [Signature]

**OWNER-BUILDER DECLARATION:** I hereby affirm under penalty of perjury that I am exempt from the contractors License Law for the following reason (Sec. 7031.5, Business and Professions Code; any city or county which requires a permit to construct, alter, improve, demolish, or repair any structure, prior to its issuance, also requires the applicant for such permit to file a signed statement that he or she is licensed pursuant to the provisions of the Contractors License Law (Chapter 9 (commencing with Section 7000) of Division 8 of the Business and Professions Code) or that he or she is exempt therefrom and the basis for the alleged exemption. Any violation of Section 7031.5 by any applicant for a permit subjects the applicant to a civil penalty of not more than five hundred dollars (\$500.00):

\_\_\_\_\_, I, as a owner of the property, or my employees with wages as their sole compensation, will do the work, and the structure is not intended or offered for sale (Sec. 7044, Business and Professional Code: The Contractors License Law does not apply to an owner of property who builds or improves thereon, and who does such work himself or herself or through his/her own employees, provided that such improvements are not intended or offered for sale. If, however, the building or improvement is sold within one year of completion, the owner-builder will have the burden of proving that he/she did not build or improve for the purpose of sale.)

\_\_\_\_\_, I, as owner of the property, am exclusively contracting with licensed contractors to construct the project (Sec. 7044, Business and Professions Code: The Contractors License Law does not apply to an owner of property who builds or improves thereon, and who contracts for such projects with a contractor(s) licensed pursuant to the Contractors License Law).

\_\_\_\_\_ I am exempt under Sec. \_\_\_\_\_ B & P for this reason: \_\_\_\_\_

Date \_\_\_\_\_ Owner Signature \_\_\_\_\_

**IN ISSUING THIS BUILDING PERMIT,** the applicant represents, and the city relies on the representation of the applicant, that the applicant verified all measurements and locations shown on the application or accompanying drawings and that the improvement to be constructed does not violate any law or private agreement relating to permissible or prohibited locations for such improvements. This building permit does not authorize any illegal location of any improvement or the violation of any private agreement relating to location of improvements.

I certify that I have read this application and state that all information is correct. I agree to comply with all city and county ordinances and state laws relating to building construction and hereby authorize representative(s) of this city to enter upon the abovementioned property for inspection purposes.

Date 11-21-00 Applicant/Agent Signature [Signature]

**WORKER'S COMPENSATION DECLARATION:** I hereby affirm under penalty of perjury one of the following declarations:

\_\_\_\_\_ I have and will maintain a certificate of consent to self-insure for workers' compensation as provided for by Section 7700 of the Labor Code, for the performance of work for which the permit is issued.

\_\_\_\_\_ I have and will maintain workers' compensation insurance, as required by Section 3700 of the Labor Code, for the performance of the work for which this permit is issued. My workers' compensation insurance carrier and policy number are:

Carrier STATE FUND Policy Number 713-00 0000502 Effective Date 10/01/2001

(This section need not be completed if the permit is for \$100 or less) I certify that in the performance of the work for which this permit is issued, I shall not employ any person in any manner so as to become subject to the workers' compensation laws of California and agree that if I should become subject to the workers' compensation provisions of Section 3700 of the Labor Code, I shall forthwith comply with those provisions.

Date 11-21-00 Applicant Signature [Signature]

**WARNING: FAILURE TO SECURE WORKER'S COMPENSATION COVERAGE IS UNLAWFUL AND SHALL SUBJECT AN EMPLOYER TO CRIMINAL PENALTIES AND CIVIL FINES UP TO ONE HUNDRED THOUSAND DOLLARS (\$100,000) IN ADDITION TO THE COST OF COMPENSATION, DAMAGES AS PROVIDED FOR IN SECTION 3706 OF THE LABOR CODE, INTEREST AND ATTORNEY'S FEE.**

**THIS PERMIT SHALL EXPIRE BY LIMITATION IF WORK IS NOT COMMENCED WITHIN 180 DAYS.**

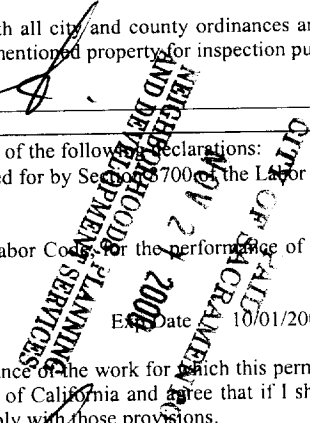

Date of Request: \_\_\_\_\_

By: \_\_\_\_\_

**CITY OF SACRAMENTO DEVELOPMENT SERVICES DIVISION  
PLANNING AND ZONING INFORMATION REQUEST**

Project Address: 22 Cloe Court

Assessor's Parcel Number: 25-1140-017

Previous Use: \_\_\_\_\_

Description of Request/Proposed Use: \_\_\_\_\_

Is This a Change of Use? \_\_\_\_\_

Zoning Designation: R-1 (PUD)

Prior Applications for Project Site(P#, Z#, DRPB#): \_\_\_\_\_

Comments: zfc letter

Are There Any Planning Issues?: (circle one) YES  NO

- \* Staff Site Plan Check Required? (Circle one) YES  NO
- \* Field Inspection Required? (Circle one) YES  NO
- \* Design Review/Preservation Required?: (Circle one) YES  NO

Planning Review by/Date: S. Lopez 21 Nov 00

A list of items that must be reviewed by Planning is provided on the reverse side of this form.

MICROFILM AFTER FINAL

LAWRIE COUNTY  
22 Cloe Ct  
SACRAMENTO, 95825  
(916) 928-1131

**ISSUED**

1.0V 2 1 2000

Sacramento Building Division

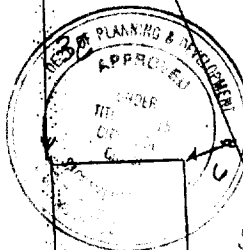

This set of plans and specifications must be kept on the job at all times and it is unlawful to make any changes or alterations to the same without written approval from the Building Division. The approval of the Building Division shall not be held as a violation of any City Ordinance.

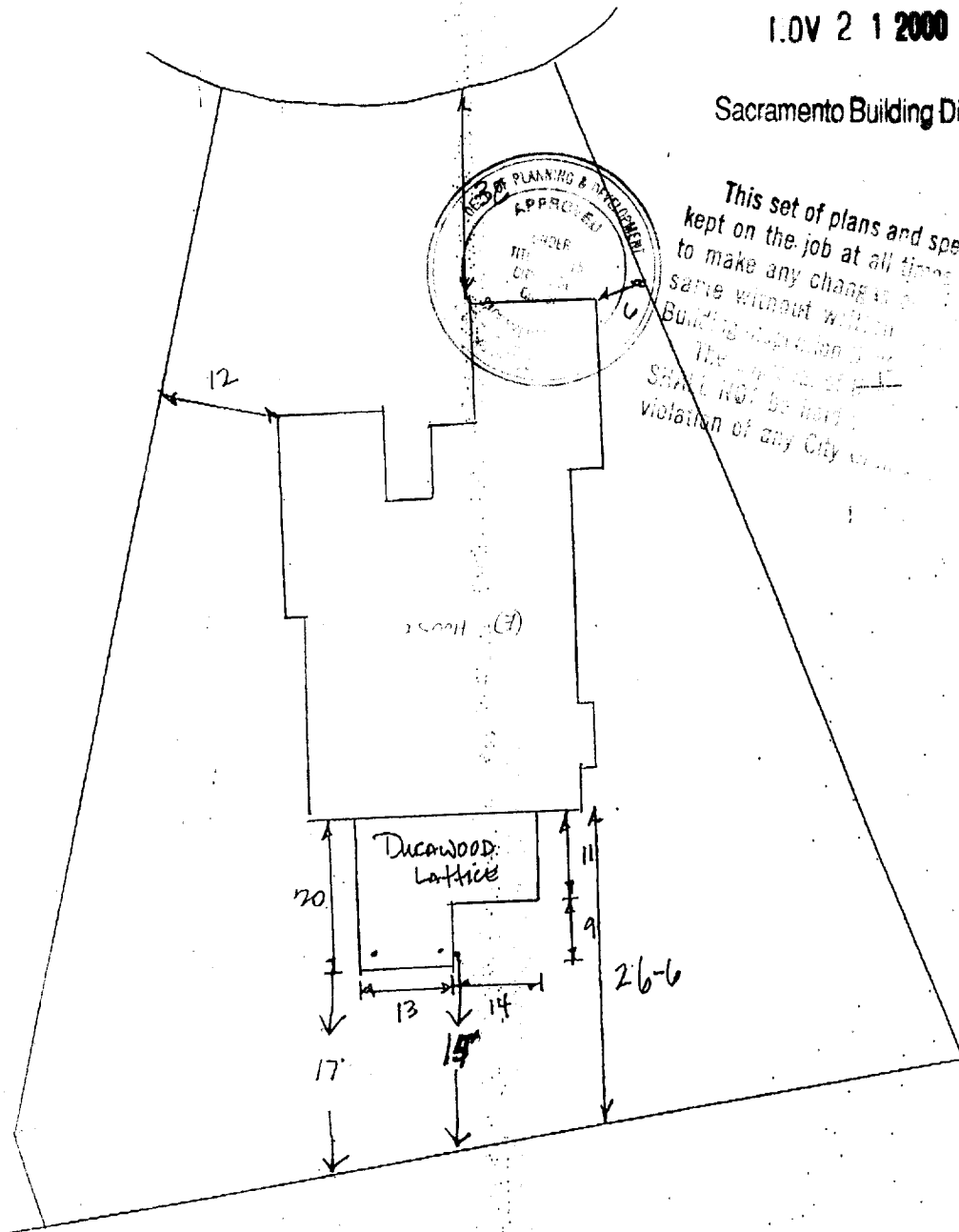

SITE PLAN APPROVED - PLANNING DIVISION

DATE: 21 Nov BY: S. Joyce  
The approval SHALL NOT be held to permit or approve the violation of any State law, City Ordinance or private agreement, and assumes that property lines and other information submitted by the applicant are accurate and complete.



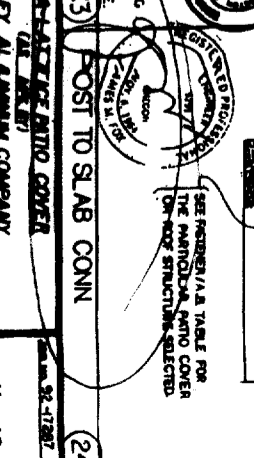
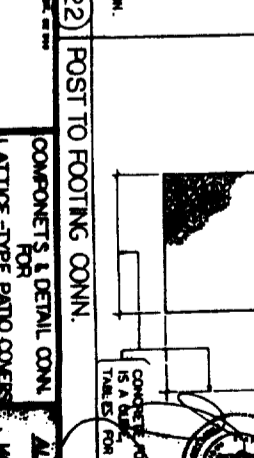
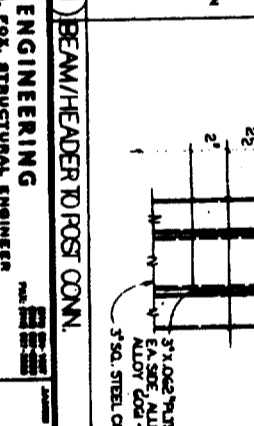
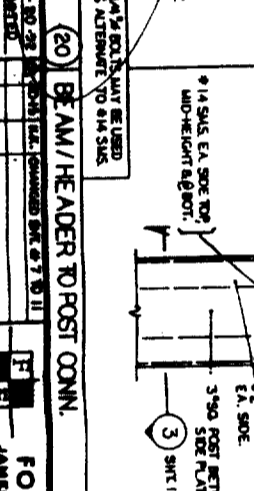
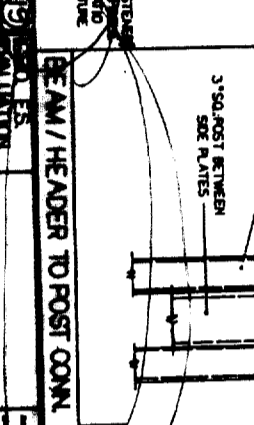
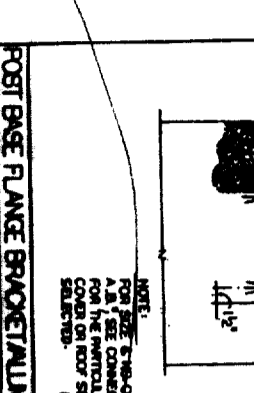
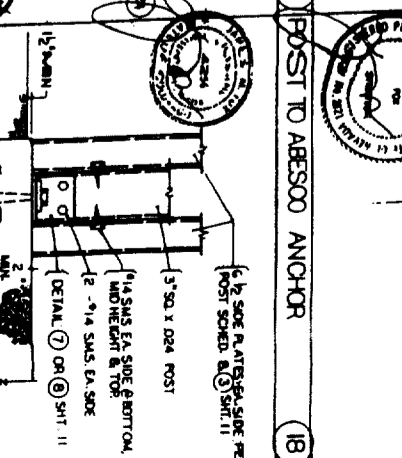
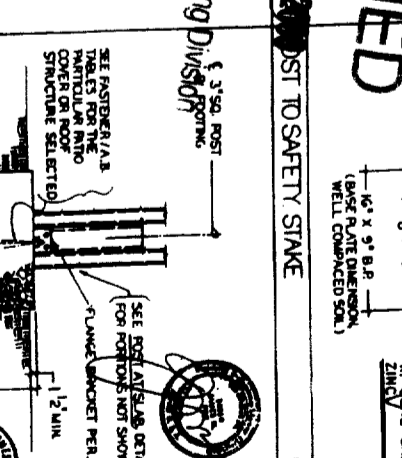
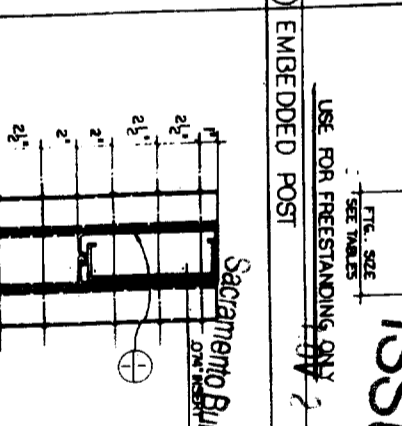
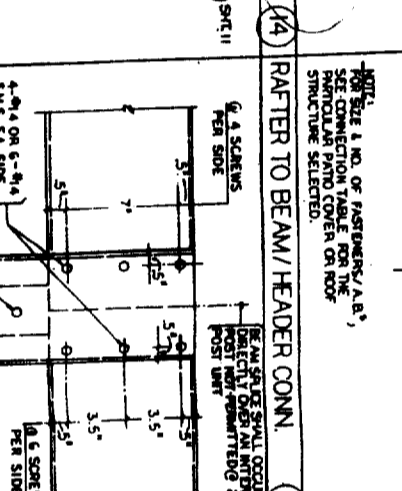
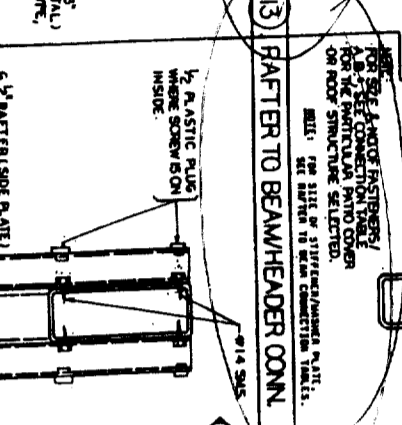
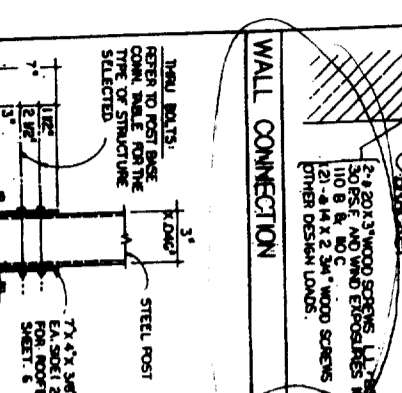
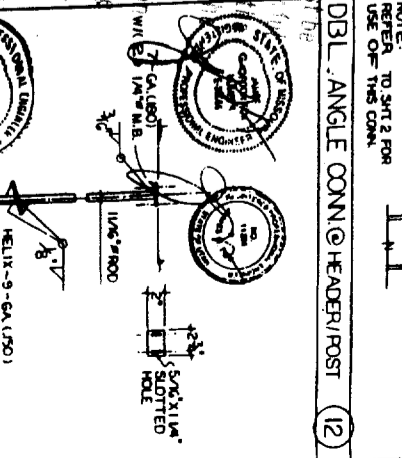
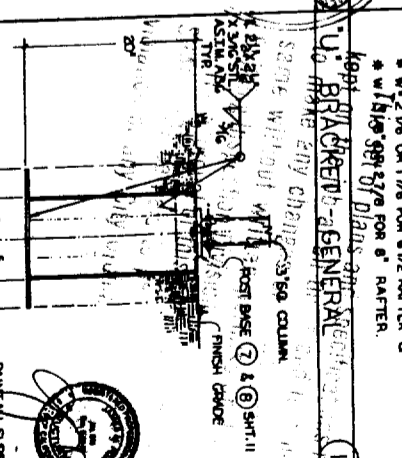
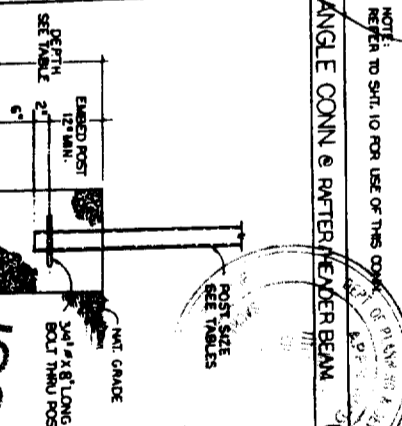
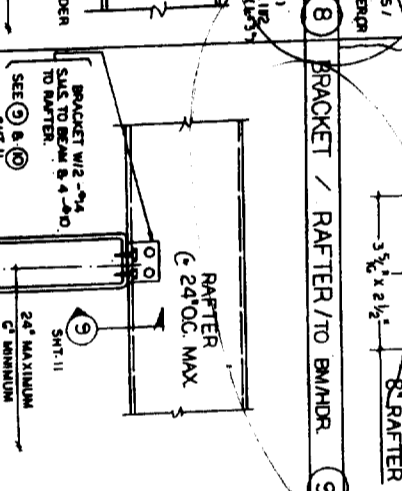
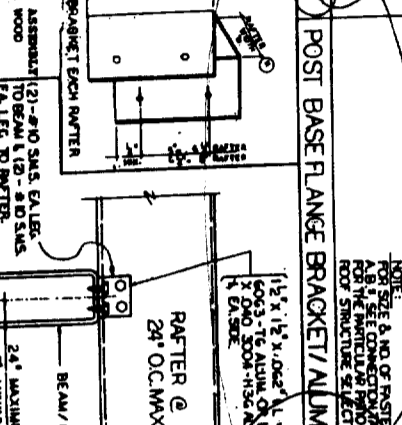
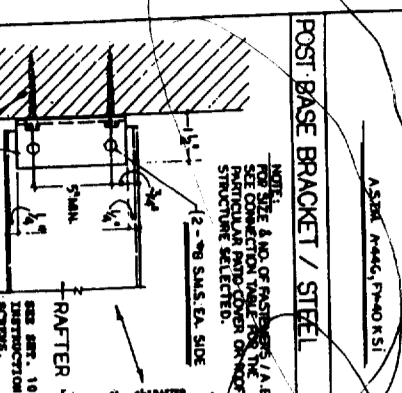
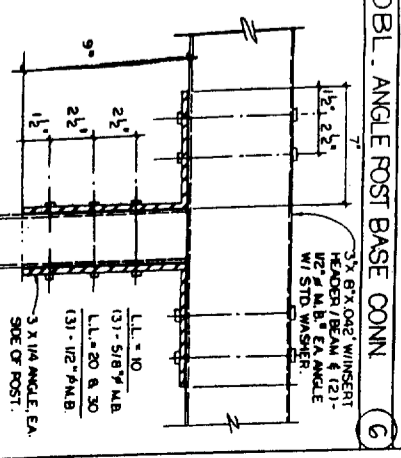
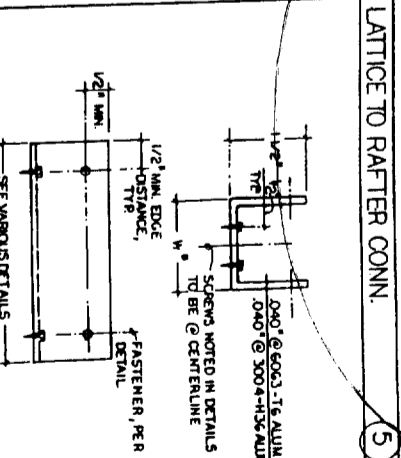
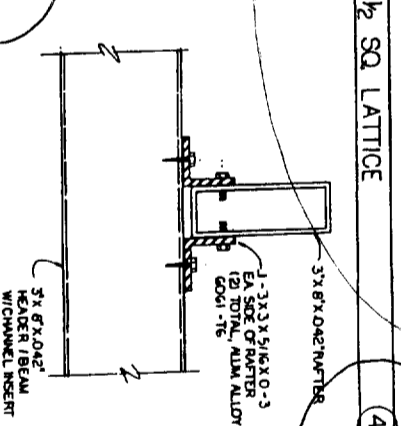
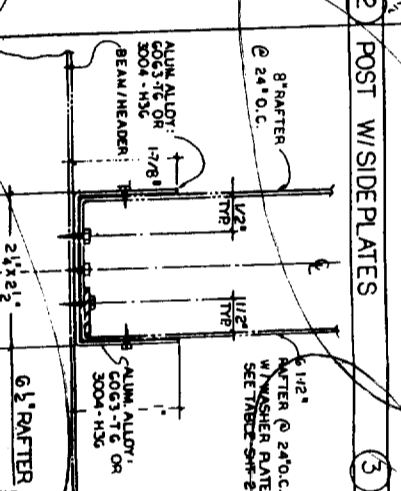
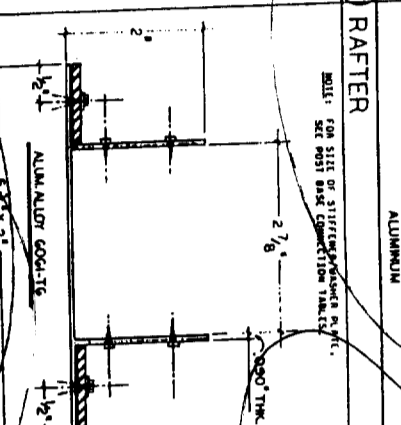
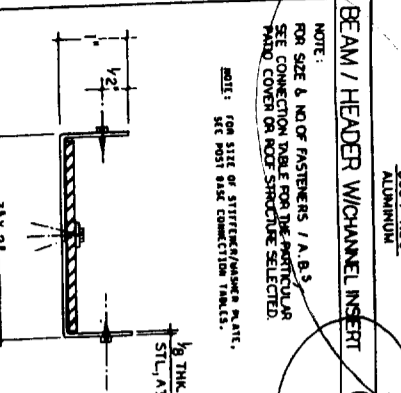
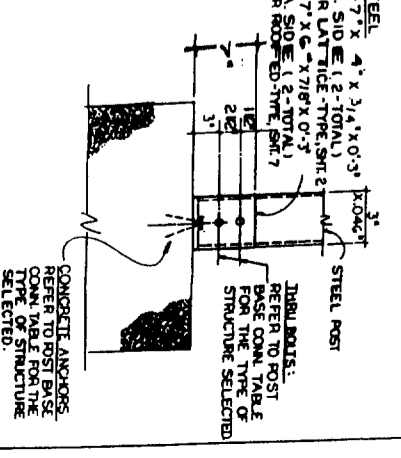
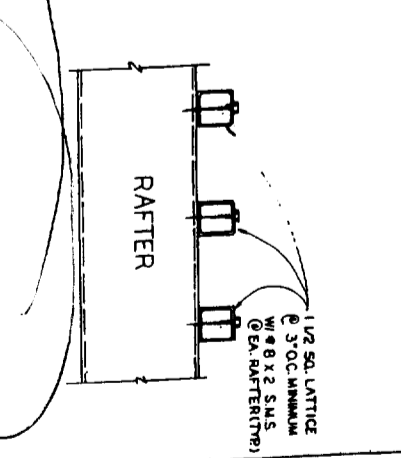
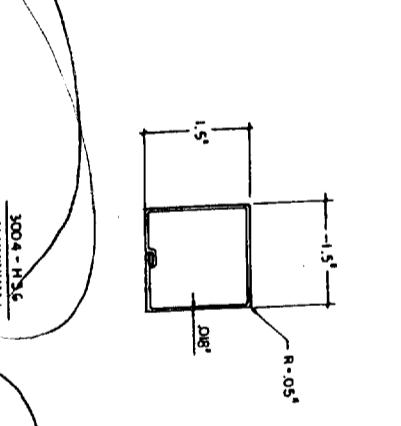
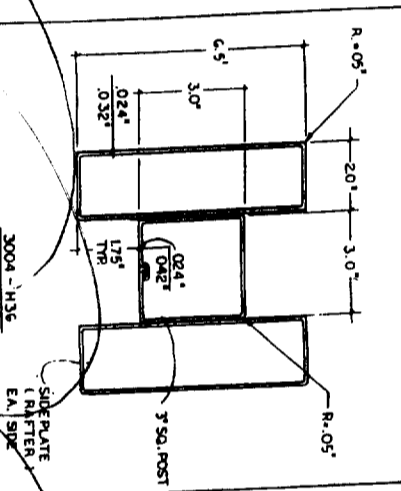
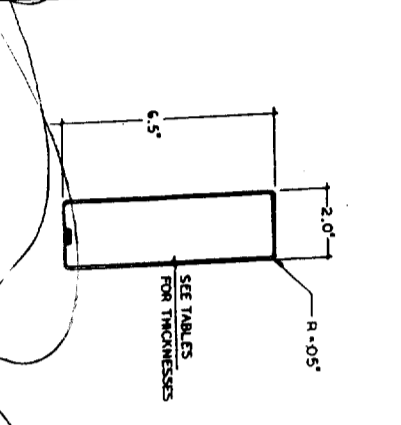
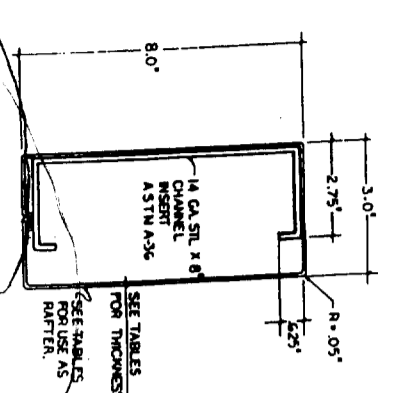

**ISSUED**

USE FOR FREESTANDING ONLY

FOX ENGINEERING  
JAMES W. FOX, STRUCTURAL ENGINEER

Sacramento Building Division