

CITY OF SACRAMENTO
1231 I Street, Sacramento, CA 95814

Permit No: 0012203
Insp Area: 2

Site Address: 6754 21ST ST SAC
Parcel No: 035-0212-007

Sub-Type: AOTHR
Housing (Y/N): N

CONTRACTOR
A&A CONSTRUCTION
5974 WILKINSON
SACRAMENTO CA 95824

OWNER
PADILLA RAMON D/ROSA MARIA
6754 21ST ST
SACRAMENTO CA 95822

ARCHITECT

Nature of Work: OLD PERMIT 9908461 EXPIRED, NEW PERMIT FOR 195 SQ FT
KITCHEN ADDITION.

CONSTRUCTION LENDING AGENCY: I hereby affirm under penalty of perjury that there is a construction lending agency for the performance of the work for which this permit is issued (Sec. 3097, Civ. C).

Lender's Name _____ Lender's Address _____

LICENSED CONTRACTORS DECLARATION: I hereby affirm under penalty of perjury that I am licensed under provisions of Chapter 9 (commencing with section 7000) of Division 3 of the Business and Professions Code and my license is in full force and effect.

License Class B License Number 736186 Date 10/11/00 Contractor Signature [Signature]

OWNER-BUILDER DECLARATION: I hereby affirm under penalty of perjury that I am exempt from the contractors License Law for the following reason (Sec. 7031.5, Business and Professions Code; any city or county which requires a permit to construct, alter, improve, demolish, or repair any structure, prior to its issuance, also requires the applicant for such permit to file a signed statement that he or she is licensed pursuant to the provisions of the Contractors License Law (Chapter 9 (commencing with Section 7000) of Division 8 of the Business and Professions Code) or that he or she is exempt therefrom and the basis for the alleged exemption. Any violation of Section 7031.5 by any applicant for a permit subjects the applicant to a civil penalty of not more than five hundred dollars (\$500.00);

____ I, as a owner of the property, or my employees with wages as their sole compensation, will do the work, and the structure is not intended or offered for sale (Sec. 7044, Business and Professional Code: The Contractors License Law does not apply to an owner of property who builds or improves thereon, and who does such work himself or herself or through his/her own employees, provided that such improvements are not intended or offered for sale. If, however, the building or improvement is sold within one year of completion, the owner-builder will have the burden of proving that he/she did not build or improve for the purpose of sale.)

____ I, as owner of the property, am exclusively contracting with licensed contractors to construct the project (Sec. 7044, Business and Professions Code: The Contractors License Law does not apply to an owner of property who builds or improves thereon, and who contracts for such projects with a contractor(s) licensed pursuant to the Contractors License Law).

____ I am exempt under Sec. _____ B & PC for this reason: _____

Date _____ Owner Signature _____

IN ISSUING THIS BUILDING PERMIT, the applicant represents, and the city relies on the representation of the applicant, that the applicant verified all measurements and locations shown on the application or accompanying drawings and that the improvement to be constructed does not violate any law or private agreement relating to permissible or prohibited locations for such improvements. This building permit does not authorize any illegal location of any improvement or the violation of any private agreement relating to location of improvements.

I certify that I have read this application and state that all information is correct. I agree to comply with all city and county ordinances and state laws relating to building construction and hereby authorize representative(s) of this city to enter upon the abovementioned property for inspection purposes.

Date 10/11/00 Applicant/Agent Signature [Signature]

WORKER'S COMPENSATION DECLARATION: I hereby affirm under penalty of perjury one of the following declarations:

____ I have and will maintain a certificate of consent to self-insure for workers' compensation as provided for by Section 3700 of the Labor Code, for the performance of work for which the permit is issued.

____ I have and will maintain workers' compensation insurance, as required by Section 3700 of the Labor Code, for the performance of the work for which this permit is issued. My workers' compensation insurance carrier and policy number are:

Carrier

Policy Number

Exp. Date

(This section need not be completed if the permit is for \$100 or less) I certify that in the performance of the work for which this permit is issued, I shall not employ any person in any manner so as to become subject to the workers' compensation laws of California and agree that if I should become subject to the workers' compensation provisions of Section 3700 of the Labor Code, I shall forthwith comply with those provisions.

Date 10/11/00 Applicant Signature [Signature]

WARNING: FAILURE TO SECURE WORKER'S COMPENSATION COVERAGE IS UNLAWFUL AND SHALL SUBJECT AN EMPLOYER TO CRIMINAL PENALTIES AND CIVIL FINES UP TO ONE HUNDRED THOUSAND DOLLARS (\$100,000) IN ADDITION TO THE COST OF COMPENSATION, DAMAGES AS PROVIDED FOR IN SECTION 3706 OF THE LABOR CODE, INTEREST AND ATTORNEY'S FEE.

THIS PERMIT SHALL EXPIRE BY LIMITATION IF WORK IS NOT COMMENCED WITHIN 180 DAYS.

Date of Request: 12/1/00
By: _____

**CITY OF SACRAMENTO DEVELOPMENT SERVICES DIVISION
PLANNING AND ZONING INFORMATION REQUEST**

Project Address: 6754 21ST ST

Assessor's Parcel Number: 035.0212.007

Previous Use: GFE

Description of Request/Proposed Use: REMOVE 2 BAY WINDOWS

Is This a Change of Use? NO

Zoning Designation: R-1

Prior Applications for Project Site(P#, Z#, DRPB#): N/A

Comments: NO DESIGN REVIEW - BAY EXTENDS 2 FEET INTO
YARD AREA - WHICH IS EXEMPT FROM SETBACK ENCROACHMENT

Are There Any Planning Issues?: (circle one) YES NO

- * Staff Site Plan Check Required? (Circle one) YES NO
- * Field Inspection Required? (Circle one) YES NO
- * Design Review/Preservation Required? (Circle one) YES NO

Planning Review by/Date: [Signature] 12/1/2000

A list of items that must be reviewed by Planning is provided on the reverse side of this form.

MICROFILM AFTER FINAL

0012203
6754 21ST ST

ISSUED

DEC 6 1 2000

Sacramento Building Division

APPROVAL OF BAY
WINDOW ROOF FRAMING
SUBJECT TO FIELD
INSPECTOR
12/1/00

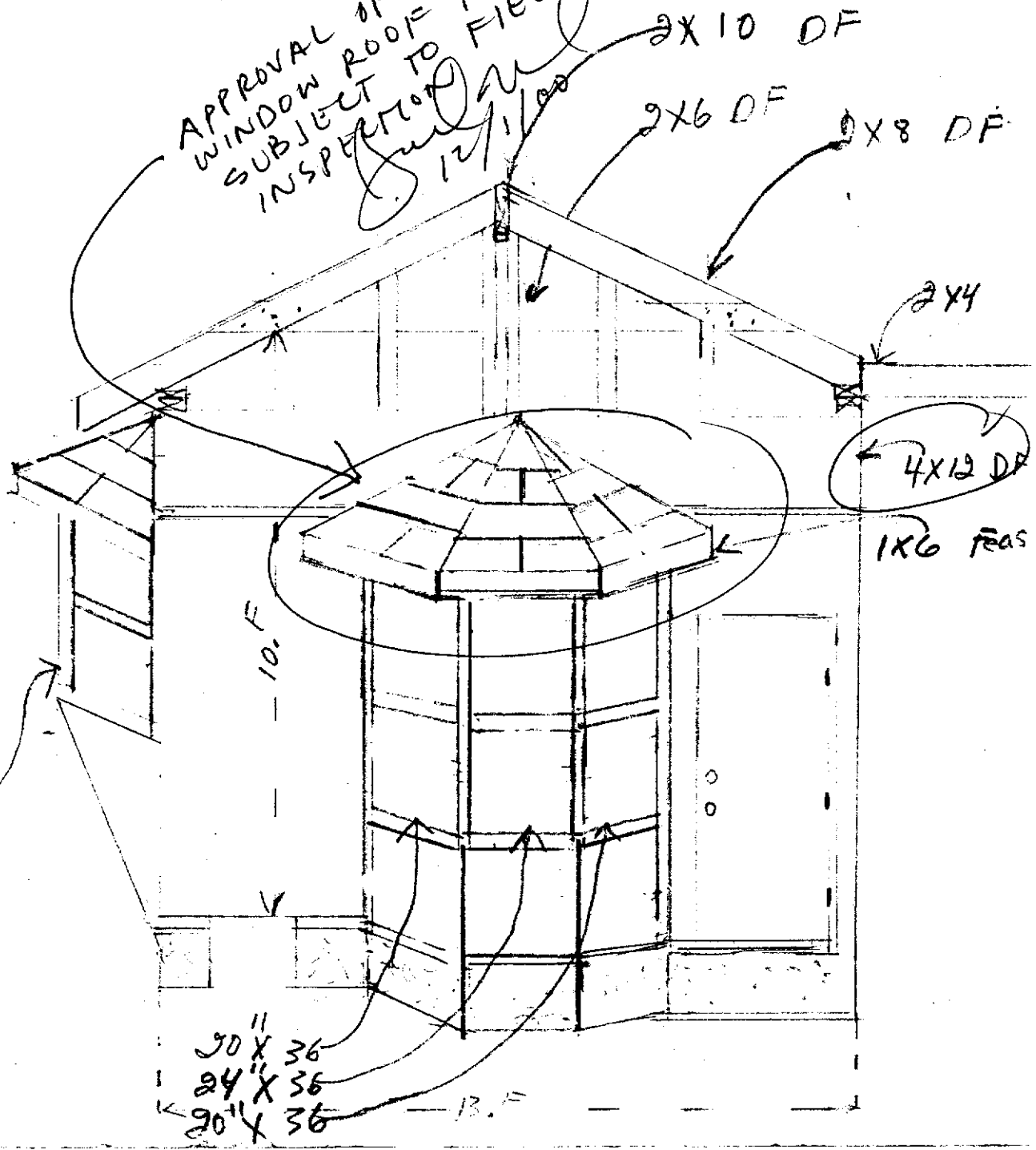

WEST ELEVATION

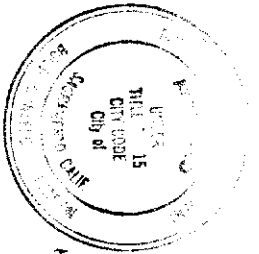

This plan is submitted for review and approval of the Building Inspection Division. It is the responsibility of the applicant to provide any information or data not shown on the same without written permission from the Building Inspection Division. The approval of this plan and specifications SHALL NOT be held to constitute an endorsement or violation of any City Ordinance or State Law.

ISSUED

LFC 0 1 2000

Sacramento Building Division

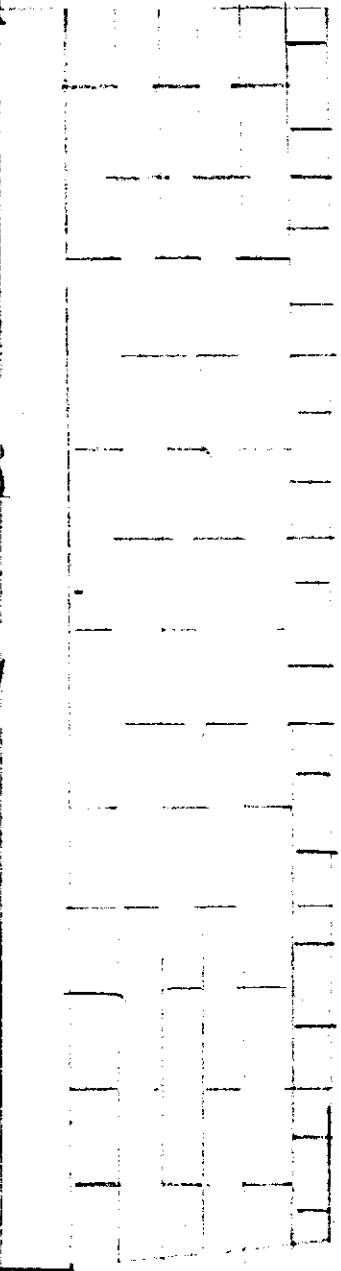

2x10 DF

1x6 Fash

80x24"

24"x34"

20x24"

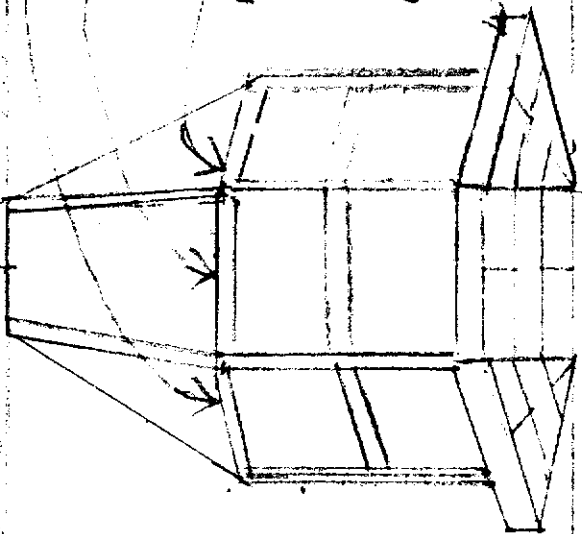

NORTH ELEVATION