

CITY OF SACRAMENTO
1231 I Street, Sacramento, CA 95814

Permit No: 0106521
Insp Area: 4

Site Address: 390 FORASTERA CR SAC
Parcel No: 225-1640-031 RIVER VIEW 2 VIL 2A LOT 78

Sub-Type: NSFR
Housing (Y/N): N

CONTRACTOR
BEAZER HOMES
3009 DOUGLAS BL #150
ROSEVILLE CA 95661

OWNER
BEAZER HOMES
3009 DOUGLAS BLVD #150
ROSEVILLE CA 95661

ARCHITECT

Nature of Work: MP 2010 1 STORY 9 ROOM SFR

CONSTRUCTION LENDING AGENCY: I hereby affirm under penalty of perjury that there is a construction lending agency for the performance of the work for which this permit is issued (Sec. 3097, Civ. C).

Lender's Name _____ Lender's Address _____

LICENSED CONTRACTORS DECLARATION: I hereby affirm under penalty of perjury that I am licensed under provisions of Chapter 9 (commencing with section 7000) of Division 3 of the Business and Professions Code and my license is in full force and effect.

License Class B License Number 724191 Date 6/8/01 Contractor Signature Sheyl Van Maen

OWNER-BUILDER DECLARATION: I hereby affirm under penalty of perjury that I am exempt from the contractors License Law for the following reason (Sec. 7031.5, Business and Professions Code; any city or county which requires a permit to construct, alter, improve, demolish, or repair any structure, prior to its issuance, also requires the applicant for such permit to file a signed statement that he or she is licensed pursuant to the provisions of the Contractors License Law (Chapter 9 (commencing with Section 7000) of Division 8 of the Business and Professions Code) or that he or she is exempt therefrom and the basis for the alleged exemption. Any violation of Section 7031.5 by any applicant for a permit subjects the applicant to a civil penalty of not more than five hundred dollars (\$500.00).

I, as a owner of the property, or my employees with wages as their sole compensation, will do the work, and the structure is not intended or offered for sale (Sec. 7044, Business and Professional Code). The Contractors License Law does not apply to an owner of property who builds or improves thereon, and who does such work himself or herself or through his/her own employees, provided that such improvements are not intended or offered for sale. If, however, the building or improvement is sold within one year of completion, the owner-builder will have the burden of proving that he/she did not build or improve for the purpose of sale.)

I, as owner of the property, am exclusively contracting with licensed contractors to construct the project (Sec. 7044, Business and Professions Code). The Contractors License Law does not apply to an owner of property who builds or improves thereon, and who contracts for such projects with a contractor(s) licensed pursuant to the Contractors License Law).

I am exempt under Sec. _____ B & PC for this reason: _____
Date _____ Owner Signature _____

IN ISSUING THIS BUILDING PERMIT, the applicant represents, and the city relies on the representation of the applicant, that the applicant verified all measurements and locations shown on the application or accompanying drawings and that the improvement to be constructed does not violate any law or private agreement relating to permissible or prohibited locations for such improvements. This building permit does not guarantee any precise location of any improvement or the violation of any private agreement relating to location of improvements.

I certify that I have read this application and state that all information is correct. I agree to comply with all city and county ordinances and state laws relating to building construction and hereby authorize representative(s) of this city to enter upon the abovementioned property for inspection purposes.

Date 6/8/01 Applicant/Agent Signature Sheyl Van Maen

WORKER'S COMPENSATION DECLARATION: I hereby affirm under penalty of perjury one of the following declarations:
I have and will maintain a certificate of consent to self-insure for workers' compensation as provided for by Section 3700 of the Labor Code, for the performance of work for which the permit is issued.

I have and will maintain workers' compensation insurance, as required by Section 3700 of the Labor Code, for the performance of the work for which this permit is issued. My workers' compensation insurance carrier and policy number are:

Carrier LIBERTY MUTUAL INS CO Policy Number WA2-651-004147-080 Exp Date 04/01/2002

(This section need not be completed if the permit is for \$100 or less) I certify that in the performance of the work for which this permit is issued, I shall not employ any person in any manner so as to become subject to the workers' compensation laws of California and agree that if I should become subject to the workers' compensation provisions of Section 3700 of the Labor Code, I shall forthwith comply with those provisions.

Date 6/8/01 Applicant Signature Sheyl Van Maen

WARNING: FAILURE TO SECURE WORKER'S COMPENSATION COVERAGE IS UNLAWFUL AND SHALL SUBJECT AN EMPLOYER TO CRIMINAL PENALTIES AND CIVIL FINES UP TO ONE HUNDRED THOUSAND DOLLARS (\$100,000) IN ADDITION TO THE COST OF COMPENSATION. DAMAGES AS PROVIDED FOR IN SECTION 3706 OF THE LABOR CODE, INTEREST AND ATTORNEY'S FEE.

THIS PERMIT SHALL EXPIRE BY LIMITATION IF WORK IS NOT COMMENCED WITHIN 180 DAYS.

#78

OMEGA PRODUCTS CORP.

DIAMOND WALL INSULATING STUCCO SYSTEM

JOB ADDRESS:

#390 Forastena
Beazer Memorus

ICBO Report #4004

Date of Job Completion 9/29/01

PLASTERING CONTRACTOR:

Name: STUCCO WORKS INC.

Address: 5900 WAREHOUSE WAY, SACRAMENTO, CALIFORNIA 95826

Telephone No: (916) 383-6699

Contractor Number of Diamond Wall System 2175

This is to certify that the exterior coating system on the building exterior at the above address has been installed in accordance with the evaluation report specified above and the manufacturer's instructions.

10/17/01
Date

[Signature]
Signature of authorized representative of
Plastering Contractor

This installation card must be presented to the building inspector after completion of work and before final inspection.

CERTIFICATION OF INSULATION

PART I GENERAL

PART II AREA CERTIFIED

PART III CERTIFICATION

ADDRESS OR TRACT <div style="font-size: 2em; font-family: cursive;">BEAZER</div> <div style="margin-left: 200px;">LOT # 78</div>	SACRAMENTO INSULATION CONTRACTORS <input checked="" type="checkbox"/> P.O. BOX 854, WEST SACRAMENTO, CA 95691 LIC. #202026 <input type="checkbox"/> 1309 MELODY ROAD, MARYSVILLE, CA 95901 LIC. #202026 <input type="checkbox"/> P.O. BOX 9651, FRESNO, CA 93793-9651 LIC. #202026 <input type="checkbox"/> P.O. BOX 1631, RENO, NV 89505 LIC. #10675 <input type="checkbox"/> 3326 A PONDEROSA WAY, LAS VEGAS, NV 89118 LIC. #10675
MEMORIES	DATE INSULATION COMPLETED <div style="font-size: 1.5em; font-family: cursive;">10/18/01</div>

WALLS		CEILINGS			FLOORS	
SQUARE FEET)		SQUARE FEET)			SQUARE FEET)	
TYPE OF INSULATION		TYPE OF INSULATION			TYPE OF INSULATION	
MATERIAL FIBERGLASS		MATERIAL FIBERGLASS			MATERIAL FIBERGLASS	
FORM BATTS		FORM BATTS & BLOW			FORM BATTS	
MANUFACTURER'S PRODUCT I.D.		MANUFACTURER'S PRODUCT I.D.			MANUFACTURER'S PRODUCT I.D.	
MANUFACTURER		MANUFACTURER			MANUFACTURER	
OCF		OCF			OCF	
BAGS						
R - VALUE INSTALLED	APPLIED THICKNESS	R - VALUE INSTALLED	APPLIED THICKNESS	MIN. INSTALLED WEIGHT PER SQUARE FOOT	R - VALUE INSTALLED	APPLIED THICKNESS
13	3 1/8"	30	9" 12"			
KNEE WALLS IF R-VALUE IS OTHER THAN WALLS ABOVE						
MATERIAL FIBERGLASS		FORM BATTS		R VALUE	MANUFACTURER OCF	
AIR INFILTRATION SEALANT						
MATERIAL <div style="font-size: 1.5em; font-family: cursive;">FOAM</div>				MANUFACTURER W R GRACE		

THIS IS TO CERTIFY THAT INSULATION AND/OR SEALANT HAS BEEN INSTALLED IN CONFORMANCE WITH APPLICABLE CODES, MATERIAL STANDARDS AND REGULATIONS.

SIGNATURE—INSULATION CONTRACTOR <div style="font-size: 1.5em; font-family: cursive;">Bill Lutz</div>	TITLE MANAGER	DATE <div style="font-size: 1.2em; font-family: cursive;">9-19-07</div>
SIGNATURE—GENERAL CONTRACTOR	TITLE	DATE

REMARKS:

Norman
Scheel
Structural
Engineer

Sacramento
5022 Sunrise Blvd.
Fair Oaks, CA 95628
(916) 536-9585
(916) 536-0260 (fax)

NORMAN SCHEEL
Structural Engineer
Email: norm@nsse.com

ROBERT COON
Project Manager
Email: rob@nsse.com

PAULO IBÁÑEZ, P.E.
Project Manager
Email: paulo@nsse.com

TIM SLOAN, P.E.
Project Manager
Email: tim@nsse.com

STEVE COOKSEY
CAD Supervisor
Email: steve@nsse.com

STACY MARLIN
Office Manager
Email: stacy@nsse.com

Davis
213 E Street Suite B
Davis, CA 95616
(530)753-5300
(530)753-5380(fax)

TRACY HARRIS, P.E.
Project Manager
Email: tracy@nsscdavis.com

DARRELL PEREIRA
Design Engineer
Email: darell@nsscdavis.com

August 14, 2001

Beazer Homes
3009 Douglas Blvd. Suite 150
Roseville, CA 95661

Re: Memories II (Job #20419)
Inspection Clarifications

To Whom It May Concern:

This letter is to clarify the following conditions:

1. Lot 78 (Plan 2010) – The service panel may be installed in the shear wall. Blocking and CS16 straps should be installed top and bottom of panel. All openings should be blocked and edge nailed along with edge nailing the full height of each stud on sides of panels.
2. Epoxy holdown repairs – The epoxy fixes required on Lots 78 and 79 are included with this letter.

If you have any questions, please call Rob Coon.

NORMAN SCHEEL
STRUCTURAL ENGINEER



PLAN ADDENDUM

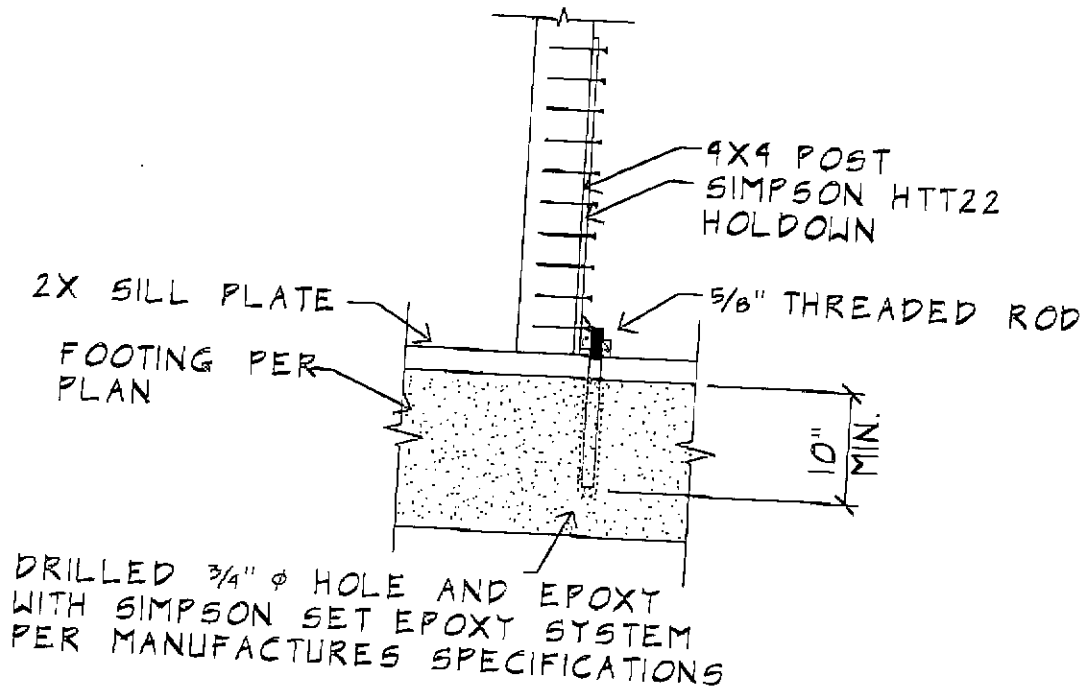

HPAHD22, L5THD8, 5THD8, 5THD10, HD-2A,
& HD-5A EPOXY FIX.

NORMAN SCHEEL
STRUCTURAL ENGINEER
5022 SUNRISE BLVD
FAIR OAKS, CA 95628
VOICE (916) 536-9585
FAX (916) 536-0260

PROJECT MEMORIES II
CLIENT BEARD
JOB NO. 20419
PROJECT MGR. ROB
DATE 8/14/01
PAGE 1 OF 1



THIS PLOT PLAN IS NOT FOR SALES PURPOSES. THIS PLOT PLAN IS FOR THE PURPOSES OF INDICATING COMPLIANCE WITH ZONING SET BACKS, GENERAL DRAINAGE DIRECTION, AND APPROXIMATE UTILITY CONNECTION. ALL OTHER DATA SHOWN HEREON IS CONCEPTUAL. THIS PLOT PLAN DOES NOT REFLECT AS-BUILT CONDITION, RETAINING WALL ARE OPTIONAL AND MAY OR MAY NOT BE CONSTRUCTED.

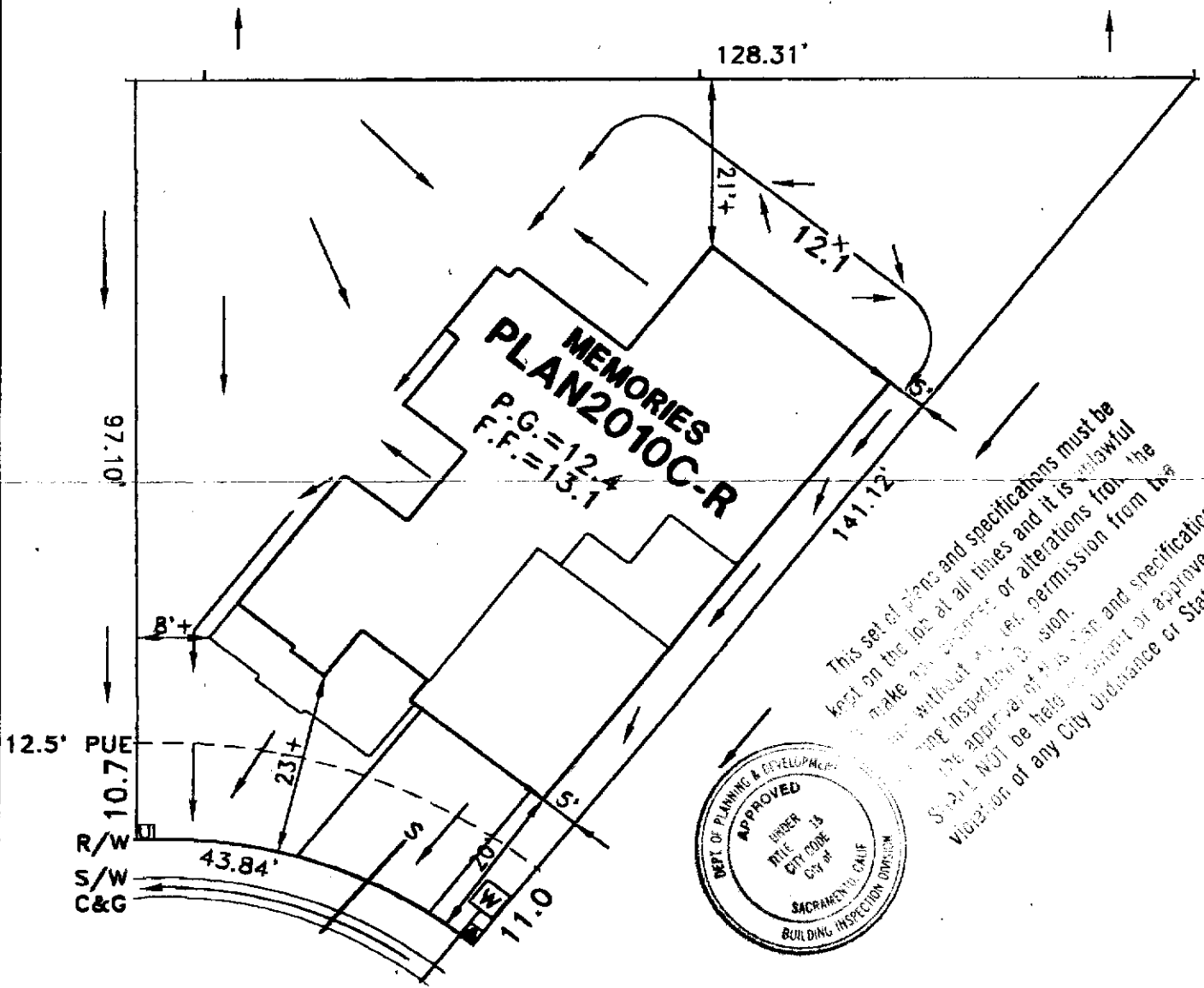
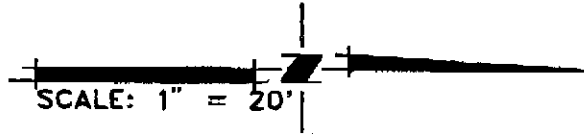

This set of plans and specifications must be kept on the job at all times and it is unlawful to make any changes or alterations from the original without the written permission from the Building Inspection Division. No work shall be held in abeyance or approved in violation of any City Ordinance or State Law.

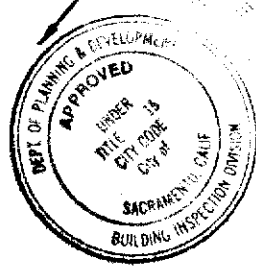

FORASTERA CIRCLE

- ☐ = UTILITY BOX
- = TRANSFORMER

ROUTING / APPROVALS	

V O

PLOT PLAN
LOT 78
RIVER VIEW #2 VILLAGE 2A
FOR
BEAZER HOMES

CITY OF SACRAMENTO CALIFORNIA

CIVIL ENGINEERING SURVEYING
MAPPING PLANNING

WOOD RODGERS INC.
3301 C STREET BLDG. 100B SACRAMENTO, CA 95816
TEL: 916/341-7760 FAX: 916/341-7767

DATE: APR 2001	DRAWN: VM	CHECKED: PWR	PROJECT NO: 1055.015
-------------------	--------------	-----------------	-------------------------

\\KRONOS\JOBS\JOBS\REVIEW\DWG\FROMREY\UNIT2\PHASE2A\LOT78.DWG 04/20/01 16:22