

CITY OF SACRAMENTO

Permit No: 9807171

1231 I Street, Sacramento, CA 95814

Insp Area: 3

Site Address: 3200 STOCKTON BL SAC

Sub-Type: NCOM

Parcel No: 0140196011

Housing (Y/N): N

CONTRACTOR

CIMORELLI CONST
11333 SUNCO DR #103
RANCHO CORDOVA

95742

OWNER

FISHER RICHARD M
1545
SACRAMENTO CA

95816

ARCHITECT

WHITELAM & WHITELAM
2102 19TH ST
SACRAMENTO CA

95818

Nature of Work: NEW BINDERY BLDG 6446 SF & SITE WORK

CONSTRUCTION LENDING AGENCY: I hereby affirm under penalty of perjury that there is a construction lending agency for the performance of the work for which this permit is issued (Sec. 3097, Civ. C).

Lender's Name

Lender's Address

LICENSED CONTRACTORS DECLARATION: I hereby affirm under penalty of perjury that I am licensed under provisions of Chapter 9 (commencing with section 7000) of Division 3 of the Business and Professions Code and my license is in full force and effect.

License Class TS License Number 525704 Date 9-30-98 Contractor Signature [Signature]

OWNER-BUILDER DECLARATION: I hereby affirm under penalty of perjury that I am exempt from the contractors License Law for the following reason (Sec. 7031.5, Business and Professions Code; any city or county which requires a permit to construct, alter, improve, demolish, or repair any structure, prior to its issuance, also requires the applicant for such permit to file a signed statement that he or she is licensed pursuant to the provisions of the Contractors License Law (Chapter 9 (commencing with Section 7000) of Division 8 of the Business and Professions Code) or that he or she is exempt therefrom and the basis for the alleged exemption. Any violation of Section 7031.5 by any applicant for a permit subjects the applicant to a civil penalty of not more than five hundred dollars (\$500.00);

I, as a owner of the property, or my employees with wages as their sole compensation, will do the work, and the structure is not intended or offered for sale (Sec. 7044, Business and Professional Code: The Contractors License Law does not apply to an owner of property who builds or improves thereon, and who does such work himself or herself or through his/her own employees, provided that such improvements are not intended or offered for sale. If, however, the building or improvement is sold within one year of completion, the owner-builder will have the burden of proving that he/she did not build or improve for the purpose of sale.)

I, as owner of the property, am exclusively contracting with licensed contractors to construct the project (Sec. 7044, Business and Professions Code: The Contractors License Law does not apply to an owner of property who builds or improves thereon, and who contracts for such projects with a contractor(s) licensed pursuant to the Contractors License Law).

I am exempt under Sec. _____ B & PC for this reason: _____

Date _____ Owner Signature _____

IN ISSUING THIS BUILDING PERMIT, the applicant represents, and the city relies on the representation of the applicant, that the applicant verified all measurements and locations shown on the application or accompanying drawings and that the improvement to be constructed does not violate any law or private agreement relating to permissible or prohibited locations for such improvements. This building permit does not authorize any illegal location of any improvement or the violation of any private agreement relating to location of improvements.

I certify that I have read this application and state that all information is correct. I agree to comply with all city and county ordinances and state laws relating to building construction and herby authorize representative(s) of this city to enter upon the abovementioned property for inspection purposes.

Date 9-30-98 Applicant/Agent Signature [Signature]

WORKER'S COMPENSATION DECLARATION: I hereby affirm under penalty of perjury one of the following declarations:

I have and will maintain a certificate of consent to self-insure for workers' compensation as provided for by Section 3700 of the Labor Code, for the performance of work for which the permit is issued.

I have and will maintain workers' compensation insurance, as required by Section 3700 of the Labor Code, for the performance of the work for which this permit is issued. My workers' compensation insurance carrier and policy number are:

Carrier Golden Eagle Ins.

Policy Number 7-99

W/C 476899-01

(This section need not be completed if the permit is for \$100 or less) I certify that in the performance of the work for which this permit is issued, I shall not employ any person in any manner so as to become subject to the workers' compensation laws of California and agree that if I should become subject to the workers' compensation provisions of Section 3700 of the Labor Code, I shall forthwith comply with those provisions.

Date 9-30-98 Applicant Signature [Signature]

WARNING: FAILURE TO SECURE WORKER'S COMPENSATION COVERAGE IS UNLAWFUL AND SHALL SUBJECT AN EMPLOYER TO CRIMINAL PENALTIES AND CIVIL FINES UP TO ONE HUNDRED THOUSAND DOLLARS (\$100,000) IN ADDITION TO THE COST OF COMPENSATION, DAMAGES AS PROVIDED FOR IN SECTION 3706 OF THE LABOR CODE, INTEREST AND ATTORNEY'S FEE.

THIS PERMIT SHALL EXPIRE BY LIMITATION IF WORK IS NOT COMMENCED WITHIN 180 DAYS.

CITY OF SACRAMENTO
30 DAY TEMPORARY CERTIFICATE OF OCCUPANCY

For Information Contact (916) 264-7619

Building Address 3200 STOCKTON BLVD. Permit No. 98-07171

Building Use New Building DBA: Fruiteridge Printing Occupancy VN F1

Building Owner Fruiteridge Printing Construction Type VN

Owner Address 3258 Stockton Blvd, Sacto., CA. Sprinkled Yes () No

Portion of Building Occupied 100% for purchase of installing Area 6220 Sq. Ft.
equipment for business operation

Date Issued 04/16/99 Expiration Date 05/16/99 Sign DENNIS RICHARDSON City Building Official ~~BRADY BOEHM, P.E.~~

~~Wagner/Rodgers/Strauss/Kobler~~
CBCT09.4 TEMPORARY CERTIFICATE

If the Chief Building Official finds that no substantial hazard will result from occupancy of any building or portion thereof before the same is completed, a temporary Certificate of Occupancy may be issued for the use of a portion or portions of a building or structure prior to the completion for the entire building or structure.

POST IN A CONSPICUOUS PLACE

COUNTY SANITATION DISTRICT NO. 1
 SACRAMENTO REGIONAL COUNTY SANITATION DISTRICT

SEWER IMPACT FEE

PERMIT AND CALCULATION SHEET

APPLICATION NO:	BLDG PERMIT NO:
GENERAL INFORMATION	THIS PERMIT GOOD ONLY WHEN VALIDATED BY THE CASHIER 9-30-98 THIS PERMIT TO CONNECT EXPIRES ONE YEAR FROM DATE OF ISSUANCE

FEE CALCULATION		BUILDING USE	
INSPECTION		RESIDENTIAL SF <input type="checkbox"/>	MF <input type="checkbox"/>
CSD-1		COMMERCIAL USE	UNITS
SRCS			
CONSTRUCTION			
IN-LIEU			
TOTAL FEE	2030		

APN: _____

DESCRIPTION/
SUBDIVISION _____ LOT: _____

PROPERTY ADDRESS **3200 STOCKTON BLVD**

OWNER _____

MAILING ADDRESS _____

CITY-STATE-ZIP _____ PHONE _____

ADDITIONAL FEES MAY BE DUE IF CHANGES IN USE INCREASE SEWER IMPACT.

APPLICANT SIGNATURE _____

CONSOLIDATED UTILITY BILLING USE ONLY

ACCT _____ INPUT _____ START _____

RECEIPT

CITY OF SACRAMENTO
APPLICATION FOR BUILDING PERMIT

9807171

→ Applicant must complete ALL Unshaded areas ←

DEVELOPMENT SERVICES DIVISION
PERMIT SERVICES DIVISION

1231 I Street, Rm. 200
Sacramento, CA 95814

(916) 264-7619 FAX 264-7046

PC# 6291 AREA # 3C

ADDRESS 3200 STOCKTON BLVD Suite _____
PARCEL # 014-0196-011

CONTACT Name <u>BRUCE WHITELAM</u> Address <u>2102 19th STREET</u> <u>SACRAMENTO CA</u> Zip <u>95818</u> Phone <u>444-1625</u> FAX <u>443-5783</u>		LICENCED CONTRACTOR Lic No. # _____ Name <u>TBA</u> Address _____ Zip _____ Phone _____ FAX _____	
ARCHITECT/ENGINEER Name <u>whitelam + whitelam</u> Address <u>2102 19th STREET</u> <u>SACRAMENTO CA</u> Zip <u>95818</u> Phone <u>444-1625</u> FAX <u>443-5783</u>		OWNER/TENANT Name <u>FRUITRIDGE PRINTING</u> Address <u>3258 STOCKTON BLVD</u> <u>SACRAMENTO CA</u> Zip <u>95820</u> Phone <u>444-1625</u> FAX _____	

→ Will the permittee have any employees on the jobsite? Yes No
 → If yes, WORKER'S COMPENSATION POLICY # _____ EXPIRATION DATE: _____
 NAME OF INSURANCE COMPANY: _____

NATURE OF WORK IN DETAIL:
(Demolish) BLDG SEP. Permit.
(N) BINDERY BLDG. - 6220 SF \$215,149.80
Site wk etc. = \$50,000

DBA: <u>FRUITRIDGE PRINTING Co.</u>		VALUATION: <u>265,149.80</u>	
FLOOD STATUS: <u>ZONE X</u>		S.C.A.T. <u>X-1 X-11 X-12 X-13 X-29 X-30</u>	
JOB DESCRIPTION: <u>BLDG</u>		SHEL APT TH() REM() SW FIRE ADD OTH	
INSP. DISCIPLINES: <u>BLDG MECH PLUMB ELEC</u>		<u>STIE FIRE</u>	
# Stories	1st flr Area	Total Area	Use Zone
	<u>6446</u>	<u>6220</u>	<u>ZONE X F1</u>
Fire Req. Y/N		Fed Code	Vio. File
Spr Y Alarm		<u>10</u>	
<u>B</u>	<u>L</u>	<u>P</u>	<u>M</u>
<u>GPLV</u>	<u>GPLV</u>		<u>E</u>
			<u>F</u>
			<u>S</u>
			<u>D</u>
			<u>R</u>

COMMENTS:
NEED
SITE WORK + LANDSCAPING
GRADING + UNDEGROUND PARKING T 50K

REGIONAL SANITATION FEES? Yes No HEALTH DEPARTMENT? Yes No

DAVE VERMILY SEAGE

PLAN CHECK ROUTING PROCEDURE

Date Received: 9/28/98 Plan Check #: 6291
 Project: 3200 STOKTON BLVD.
 Address: 4 BINDER BUILDING FOR ADT ACCT PRINTS HOP
 Legal Description: 014-0196-011 Fire Zone: _____
 Contractor: TBA Telephone: _____
 Address: _____ City License: _____
 Architect: WHITE LAM & WHITE LAM Telephone: 444-1625

PUBLIC WORKS - ENGINEERING TRANSPORTATION:
 927 - 10th Street, Room 100, Ron Perry

CIVIL ENGINEERING Date Received: _____
 Approved: [Signature] Disapproved _____
 Total frontage length of New Street Improvements: EXIST LE _____
 Comments: APPROVED FOR ON-SITE GRADING & DRAINAGE
ENCROACHMENT/EXCAVATION PERMIT REQUIRED
 Right of Way Dedication : Approved N/A Disapprove _____
 Public Improvement Agreement: Approved N/A Disapprove _____
 Surety Bond, etc. : Approved N/A Disapprove _____
 Staking and Inspection Fee : N/A \$ _____

TRAFFIC ENGINEERING
 927 - 10th Street, Room 100, Paul Favilla

Approved: [Signature] Disapproved _____ Date Received: _____
 Need new driveway permit _____
 No driveway permit needed NO NEW PERMIT REQUIRED
 Removal of abandoned driveway _____
 Comments: ENCROACHMENT/EXCAVATION PERMIT REQUIRED

PUBLIC WORKS - WATER & SEWER, PLANNING, ARCH, REVIEW COMMITTEE,
 927 - 10th Street, Room 100, Ron Perry

Approved: [Signature] Disapproved _____ Date Received: _____
 Comments: APPROVED

SITE CONDITIONS UNIT (264-7619)
 Steve Reed, Gary Spross, Wes Jigour

Approved _____ Approved with Changes _____ Date Received: _____
 Review Zone: _____ Disapproved _____
 Special Permit: _____ Variances: _____
 Parking Spaces Furnished: _____ Parking Spaces Required: _____
 Comments: _____

ARCHITECTURAL ADVISORY COMMITTEE
 (264-5604) Dick Hastings

Date Received: _____
 Is property located in a Civic Improvement District _____
 Meeting Approved _____ Approved with Changes _____ Disapproved _____
 Item# _____ Comments _____
 P# _____

1 COPY TO UTILITIES; 1 COPY TO PUBLIC WORKS; 1 COPY SITE; ORIGINAL IN FOLDER

**City of Sacramento
Water and Sewer Service Quotation**

FY 98/99

Date: 10-Sep-98	Time: 01:39:34 PM	Building Permit No.: B98-68	Plan Check No.: 6291
Address: 3200 Stockton Boulevard		Parcel no.: 014-195-010, 011, 012	
Description: Fruitridge Printing Co.			
Subdivision Map:			Water Plan No.:
Estimate by: Dilley	Bldg. Insp. Reviewer:		
Engineering Firm: Cooper Thorne			
Sewer Jurisdiction: City Sewer			
Comment No. 1 1-1.5" water tap and 1.5" meter; prorated development fee Comment No. 2 1-4" fire tap Comment No. 3 Abandon a .75" water tap Comment No. 4 1-6" sewer tap			
TOTAL WATER DEV. FEES: 2,579.00		18.0 hrs x \$75 /hr =	1350.00
TOTAL SEWER DEV. FEES: 278.00		or \$300.00 (whichever is greater)	
total on-site grading and drainage review fee:			1,350.00

Water Service Quotations

Main Size	Service Size	Description	Qty	Tap Fee/ea.	Meter Fee/ea.	Total Tap Cost	Dev. Fees
6"	1-1/2"	Complete Service	1	1,650.00	500.00	2,150.00	2,579.00
6"	4"	Complete Service	1	2,655.00	0.00	2,655.00	0.00
	3/4"	Abandon Exist. Service		510.00		510.00	
						0.00	
						0.00	
	No			Fire Hydrant:		0.00	
Total for Water:						5,315.00	
Acreage Charge:							0.00

Sewer Service Quotations

Main Size	Service Size	Description	Qty	St. (FT)	MH Fee/ea.	Tap Fee/ea.	Total Cost	Dev. Fees
8"	6"	Complete Service	1	20	0	101.24	1012.40	278.00
							0.00	
							0.00	
							0.00	
							0.00	
Total for Sewer:							1,012.40	

Note: Total cost = Qty. x St/2 x Tap Fee + MH Fee

No	Water Main Construction Charge:	0.00
Total For Address:		6,327.40

Water development fees are based on the size of domestic service. total water development for commercial property includes a \$3,058.00 per acre charge in addition to the standard fee.



City of Sacramento Development Services Division
Planning and Zoning Information Request

Project Address: 3200 STOCKTON BLVD.

Assessor's Parcel Number: 014-0196-011

DENO (E) BLDG.
Description of Request: (N) BINDERY BLDG.

SITE WORK, Landscaping
parking

Zoning Designation: C-2

Prior Applications for Project Site(P#,Z#,DRPB#): Z98-013 [DR86-213
(Lot Line Merge) ↓

Comments: Site conditions limit DR98-068
needs to pull file for
Z98-013 and DR98-068

Are There Any Planning Issues?: (Circle One) YES NO

Planning Review Required? (Circle One) YES NO

Design Review/ Preservation Required?: (Circle One) YES NO

Planning Review by/Date: M. W. Venturian 7-28-98

For a list of items that must be reviewed by Planning, please see reverse side of this form.

DEPT. OF UTILITIES

Test # 98-181

AUG-04-1998 14:22
WATER SUPPLY TEST - DEPT. OF UTILITIES
1185 23TH AVENUE
SACRAMENTO, CA 95823
PHONE: 916 / 244-1400
FAX: 916 / 244-1407

DEPT. NO. 98-181 FILE NO. R98-0181

REQUEST DATE: 8/2/98
COMPLETE DATE: 8-15-98

PHONE NO: 226-1625 FAX NO: 226-9703

COMPANY: WHITELAM+WHITELAM
STREET ADDRESS OF TEST: 3200 STOKTON BLVD
ADDRESS LABEL NUMBER: 018-0181-01

TERMS OF TEST:

The undersigned agrees to the following terms and conditions:

- The street address shown above is correct.
- Water supply data is developed from several sources of information which may include water supply test data, pipe network computer models, and continuous pressure recording stations. The design water supply data given below is to be used for design purposes.
- Although the water supply data reported herein is believed to be correct, the City makes no warranty, guarantee, certification or other representation of any kind that such data is correct or correct on the grounds that the City, its officers and employees shall not be liable for any losses or injury resulting from the use of or reliance upon the water supply data reported herein by the undersigned or by any third party.
- If the undersigned desires to witness the water supply test performed by the City, please check the box below.
- If the undersigned desires to hire a licensed engineer, at the undersigned's sole expense, to witness and certify the water supply test performed by the City, please check the box below.

In my opinion, I will arrange for a licensed engineer to witness and certify the water supply test, which will be conducted at the convenience of the Department of Utilities.

Print Name: WHITELAM Signature: [Signature] Date: 8/19/98

ENGINEERING REQUEST DATE: 8-5-98 DATE OF TEST: 8-10-98 TIME OF TEST: 8:35

WATER MAIN SIZE: 8" TEST CONDUCTED BY: Colasanti, Stuklin's Per. Logs

	ELEV. @ FT.	MAP PAGE	STATIC PRESS. (PSI)	RESIDUAL PRESS. (PSI)	PISTON PRESS. (PSI)	OUTLET DIA. (IN.)	COMPONENT		GALL. FLOW @ 100 FT. (G.P.M.)	FLOW @ 100 FT. (G.P.M.)
							C	A		
RESIDUAL	50.31		47.37						856	
FLOWED	43.31				26	2.5	0.90	1	934	
FLOWED	63.31				31	2.5	0.90	1	1790	
FLOWED										

• THE WATER SUPPLY TEST DATA IS NOT TO BE USED FOR THE DESIGN OF DOMESTIC WATER SYSTEMS.
• (STATIC PRESS. - RESIDUAL PRESS.) / (STATIC PRESS. - 20 PSI) IS LESS THAN 20%. THEREFORE, THESE RESULTS ARE ONLY VALID FOR FLOWS NOT EXCEEDING 0.7 M.G.P.M.

$$Q = 29.83 C_c D^3 \sqrt{P_{stat}}$$

$$Q_{98} = Q \left(\frac{P_{stat} - 20}{P_{stat} - P_1} \right)^{0.5}$$

WATER SUPPLY DATA SUMMARY

MEASURE	VALUE	UNIT
STATIC PRESS.	47	PSI
RESIDUAL PRESS.	26	PSI
PISTON PRESS.	1800	PSI
OUTLET DIA.	2.5	IN.
COMPONENT	1	
GALL. FLOW @ 100 FT.	934	G.P.M.
FLOW @ 100 FT.	1790	G.P.M.

2800

(1) The Design Water Supply Data reflects fluctuations and future demands on the water distribution system. It is to be used for design purposes.

7/1998
TOTAL P. 02

R98-0181

SACRAMENTO CITY UNIFIED SCHOOL DISTRICT

CERTIFICATION OF COMPLIANCE SCHOOL DISTRICT DEVELOPMENT FEES

PROPERTY OWNER'S NAME	FISHER HAUSMANN FAMILY TRUST		
OWNER'S ADDRESS	1545 34th St. Sacramento CA 95816		
PROJECT ADDRESS	3200 STOCKTON BLVD.		
PARCEL NUMBER	011-0196-011	LOT NUMBER	
SUBDIVISION NAME			
NUMBER OF UNITS	1		
APPLICANT'S SIGNATURE	<i>Richard M Fisher</i>		
TITLE OF APPLICANT	Owner		
DATE	9-29-98	TELEPHONE NUMBER	(✓) 452-4234 454 0951H
PLAN IDENTIFICATION NUMBER	6291		
BUILDING TYPE (CHECK ONE)	<input type="checkbox"/> RESIDENTIAL <input type="checkbox"/> APARTMENT/CONDOMINIUM <input checked="" type="checkbox"/> COMMERCIAL/INDUSTRIAL		
SQUARE FEET OF CHARGEABLE BUILDING AREA	6225 SF	6446 SF	W.P. Brock ET AL
SIGNATURE	<i>Barbara A Lasso</i>		
TITLE	Bldg Tech		
		DATE	7/29/98
DISTRICT CERTIFICATION NUMBER	6472		
EXEMPT	COMMENTS		
RESIDENTIAL / APARTMENT / ETC.	_____	SQ. FT. X \$ _____	= \$ _____
COMMERCIAL / INDUSTRIAL	6446	SQ. FT. X \$.28	= \$ 1804.98
OTHER FEE _____	TYPE _____	SQ. FT. X \$ _____	= \$ _____
TOTAL FEES COLLECTED.....			\$ 1804.98

This certification covers only the amount of square footage indicated above. Any additions or corrections to the square footage for this project will require an amendment to the Certificate of Compliance.

As the authorized school district official, I hereby certify that the requirements of Government Code Section 65995 and any other authorized requirements have been complied with by the above signed applicant.

SIGNATURE	<i>[Signature]</i>		
TITLE	CIVIC CENTER PERMIT	DATE	9/30/98

91a:certcomp

Distribution: Original--School District; 1st Copy--School District; 2nd Copy--Building Department; 3rd Copy--Applicant

CITY OF SACRAMENTO
 BUILDING INSPECTION DIVISION
 APPLICATION FOR BUILDING PERMIT - HAZARDOUS MATERIAL SURVEY

As Required by Assembly Bill #3205 - A Building Permit Cannot be Approved Without This Completed Form

1. Business Name: Fruitridge Printing Phone: _____
 Site Address: 3200 Stockton Island Suite: _____
(Street) (Zip)
 Business Owner/Representative: Bret Hogge Phone: 635 4440
 Nature of Business: Printing - Bindery
 Property Owner: Richard Fisher Phone: _____
 Address: 3258 Stockton Island Suite: _____
(Street) (City) (State) (Zip)
Sacramento CA 95820

2. Are you developing an undetermined tenant space? Yes ___ No Is this permit for a shell building? Yes ___ No

Notify lessee of the responsibility to coordinate with the Fire Department regarding the use and handling of hazardous materials.

3. Does/Will your business generate hazardous waste? Yes ___ No
 4. Does/Will your business handle, store or transport any solid, liquid, or gaseous chemicals? Yes ___ No

CONSULT THE EPA CHEMICAL LIST LOCATED AT THE BUILDING DIVISION COUNTER FOR HAZARDOUS OR ACUTELY HAZARDOUS MATERIALS TO COMPLETE THE FOLLOWING QUESTIONS.

If you answered "YES" to questions #3 and/or #4 above, continue on to questions 5 - 8.

5. Do you handle, store, or transport 55 gallons, 500 pounds, or 200 cubic feet (at Standard Temperature or Pressure) of a product or formulation containing hazardous materials at any one time? Yes ___ No ___
 6. Do you handle, store or transport any amount of acutely hazardous materials? Yes ___ No ___
 7. Is/Will your business be located within 1,000 feet of a school? Yes ___ No ___

If you answered "yes" to questions #6 and/or #7, complete the RMPP Informational sheet.

8. Is/Will your business be located within 1,000 feet of a hospital, and/or long-term healthcare facility? Yes ___ No ___

IF YOU ANSWERED "YES" TO QUESTION #3 AND/OR #4, PLEASE CONTACT THE CITY OF SACRAMENTO FIRE DEPARTMENT LOCATED AT 1231 I STREET, SUITE 401, SACRAMENTO, CA OR CALL 449-5416.

Prior to issuance of a certificate of occupancy, each business owner(s) shall contact the City of Sacramento Fire Department and comply with the Health and Safety Code regarding the use and handling of hazardous materials.

PENALTY: Any business that violates Section 25531-25541 of the Health and Safety Code shall be civilly liable to the administering agency in an amount of not more than two thousand dollars (\$2,000) for each day in which the violation occurs. If the violation results in, or significantly contributes to, an emergency, including a fire, the business shall also be assessed the full cost of the city emergency response, as well as the cost of cleaning up and disposing of the hazardous materials. Additional liability and punishment may be assessed for knowing a violation after reasonable notice of the violation.

Applicant's Name: Bret Hogge
(Print)
Bret Hogge 9-30-98
(Signature) (Date)

BID Use Only: Plan Ck# _____	Permit # <u>9807171</u>
OK to issue prmt? <input checked="" type="checkbox"/> <u>9-30-98</u>	F.D. Appr Req'd? Yes No
<small>init date</small>	
Hold on Certificate of Occupancy? Yes <input checked="" type="checkbox"/> No	
Fire Dept. Use Only:	
OK to issue permit? init _____ date _____	
OK to issue Certificate of Occupancy? init _____ date _____	



BEVIER
STRUCTURAL ENGINEERING

WILLIAM D. BEVIER
STRUCTURAL ENGINEER, INC.

2893 SUNRISE BLVD., SUITE 209
RANCHO CORDOVA, CA 95742
PHONE (916) 631-3030 FAX (916) 631-8996

TO: Mr. Bruce Whitelam

Whitelam & Whitelam

2102 19th Street

Sacramento, CA 95818

DATE	1/05/99	JOB NO.	98070
PROJECT	Fruitridge Printing		
LOCATION	Stockton Blvd. Sacramento, CA		
CONTRACTOR	Cimorelli Construction	OWNER	
WEATHER	Foggy	TEMP	45 ° 11:00 AM
PRESENT AT SITE	Jim Phillips, Steve Madison, Bruce Whitelam		

THE FOLLOWING WAS NOTED:

1. The two wall anchors located at the South East corner just West of Gridline 3 are called out on Sheet S2.1 as PAI35 straps. These were installed as Simpson LTTI31 using Simpson ET22 adhesive. The Simpson ET22 product is not ICBO approved for CMU construction. This installation is sufficient provided a pull test is performed for a minimum load of T=3600#.
2. Section C/S4.2 shows the roof joists strapped to the studs with H2 clips at 48"cc. The straps were substituted with a flat strap to blocking between studs, which is not sufficient. The attached Detail, RC/S4.2, shows an alternate method to the Section H2 clips in C/S4.2.
3. Detail D/S4.3 shows the open web wood trusses headed off with 2-2x12 at the mechanical opening. This was actually built using ladder framing in lieu of the trusses and 4x framing around the opening. This method is satisfactory as long as the items in the attached Detail RD/S4.3 are followed.

Fruitridge Printing
January 5, 1999
Page 2

4. See attached Detail 1/S4.2 for where the ledger splice in Detail C/S4.2 lands at the same location as the roof joist.

Please call with any questions.

Sincerely,

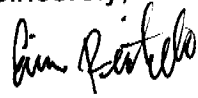

Eric Reitzell
WILLIAM D. BEVIER
STRUCTURAL ENGINEER, INC.

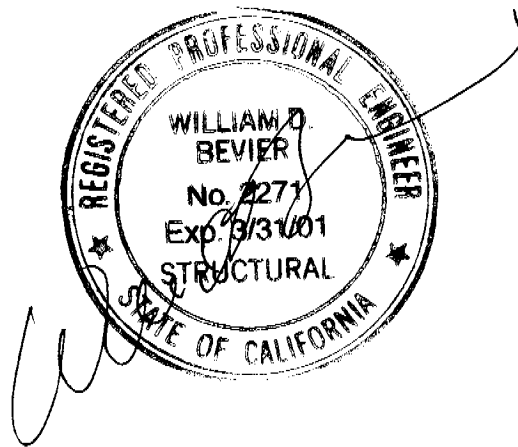

JOB FRUITRIDGE PRINTING

98070



WILLIAM D. BEVIER
STRUCTURAL ENGINEERING, INC.
2893 SUNRISE BLVD., SUITE 209
RANCHO CORDOVA, CA 95742
(916) 631-3030 FAX (916) 631-8996

CLIENT

JOB NO.

DESIGNED BY

DATE 1/5/99 PAGE

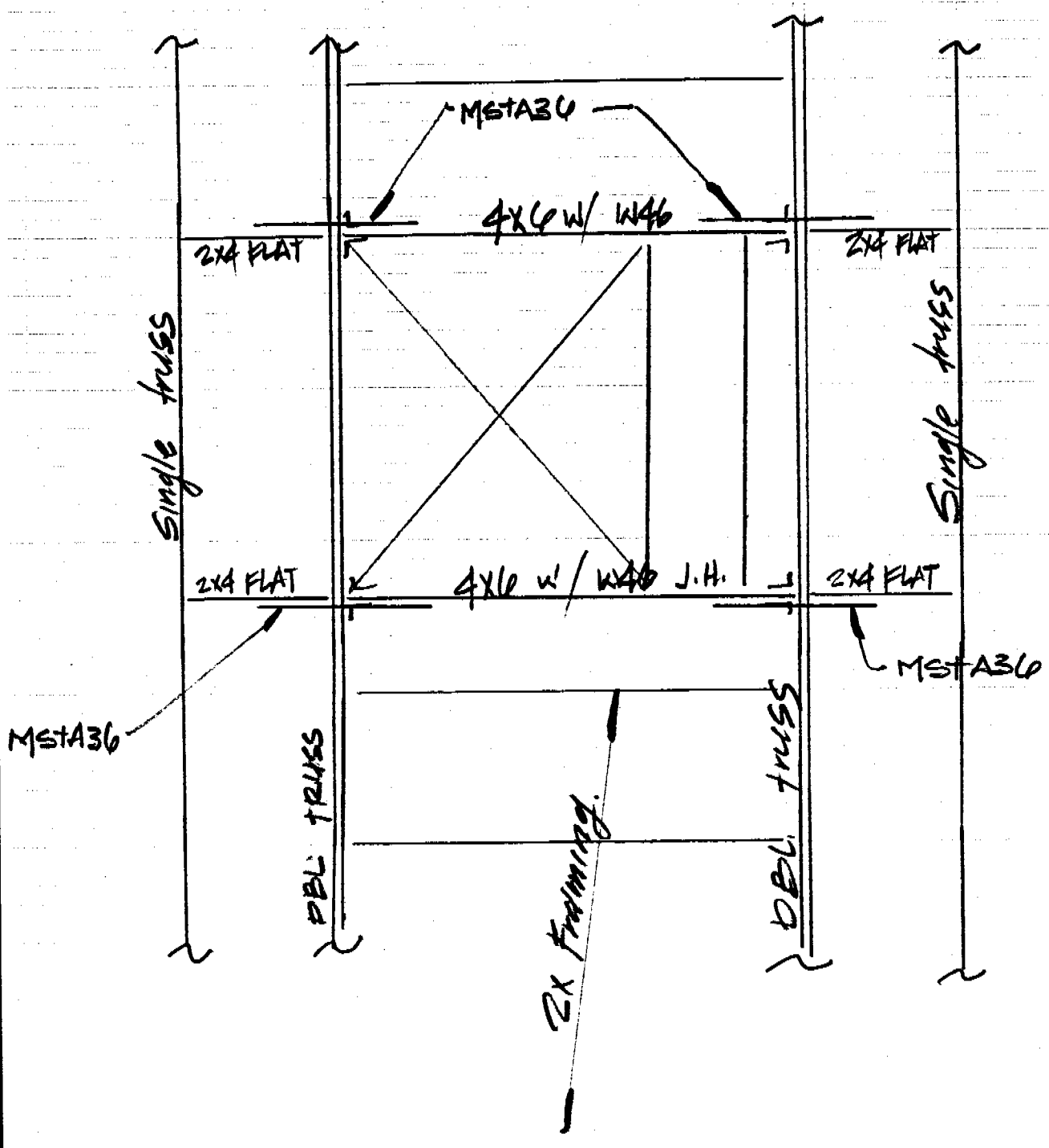

DETAIL

RD
54.3

1/2" = 1'-0"

JOB Fruitridge printing

78070



WILLIAM D. BEVIER
STRUCTURAL ENGINEERING, INC.
2893 SUNRISE BLVD., SUITE 209
RANCHO CORDOVA, CA 95742
(916) 631-3030 FAX (916) 631-8996

CLIENT

JOB NO.

DESIGNED BY ER

DATE 1/5/99 PAGE

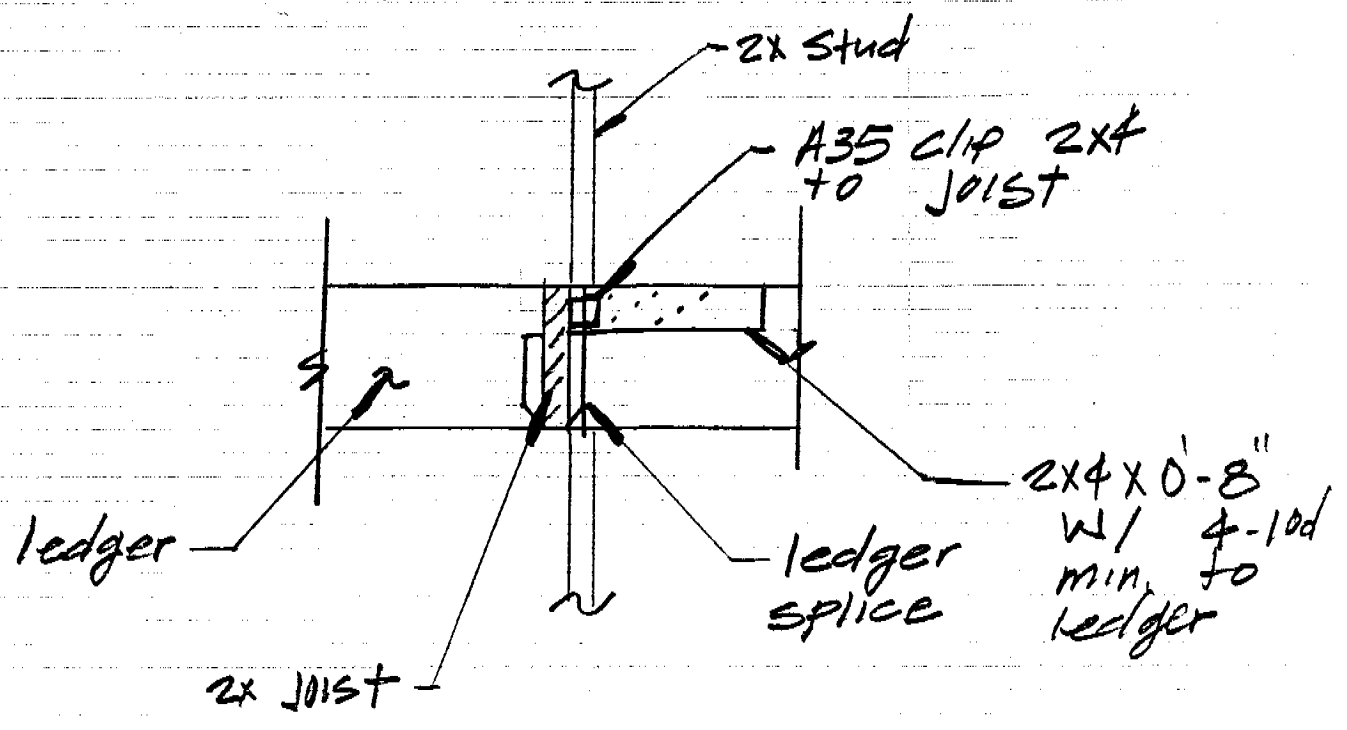

Detail



3/4" = 1'-0"



April 15, 1999

City of Sacramento
Development Services Division
1231 I Street, Room 200
Sacramento, CA 95814

Attn: Chief Building Official

RE: Fruitridge Printing Building Permit #98 07171
3200 Stockton Blvd.

We request that a Temporary Certificate of Occupancy be issued at the above noted business location to be in effect on 04/15/99 and expire at 12:00 p.m. on 05/15/99 for the purpose of installing equipment for business operation. All portions of the tenant suite will be occupied.

We acknowledge that only the following list of items will not be completed at the time of the Temporary Certificate of Occupancy:

1. Install electrical equipment for final electrical inspection.
2. Additional Knox padlock required for second vehicle gate.
3. Install landscaping and irrigation.
4. Provide planter retainer on Stockton Blvd. and on 7th Ave.
5. Screen mechanical equipment.
6. Provide bike racks.

Prior to the expiration of the expiration of the Temporary Certificate of Occupancy, we will schedule inspections to insure that all issues as stated in the above list are resolved to the full satisfaction of both the Development Services Division and Fire Department. It is hereby acknowledged that upon the expiration of the Temporary Certificate of Occupancy, if a permanent Certificate of Occupancy has not been obtained, the continued occupancy of the subject premises shall constitute a violation of applicable Building, Housing and Dangerous Building Codes, subject to criminal sanctions, civil penalties, and/or administrative penalties pursuant to such Codes.

The undersigned certify under penalty of perjury under the laws of the State of California that the foregoing is true and correct.

Dick Fisher
Owner
Fruitridge Printing
916 452 9213: 916 452 6020 fax

Bret Hogge
Development Consultant
Cimorelli Construction
916 635 4440: 916 635 7084 fax

Bret 417 4569

POST THIS CARD IN A CONSPICUOUS PLACE!

SACRAMENTO CITY FIRE DEPARTMENT

1231 I STREET, SUITE 401
SACRAMENTO, CA 95814-2979

**FIRE PREVENTION DIVISION
INSPECTION SERVICES**

FOR INSPECTIONS _____ CALL (916) 264-5480

NOTICE OF 48 HOURS REQUIRED FOR INSPECTIONS

PERMIT # 9901926 APPROVED BY BJ FOSTER
PROJECT INSURANCE CO
ADDRESS 3290 STOCKTON BLVD
OWNER (Sprinkler only)

NOTE

- 1) DO NOT COVER WALLS, CEILINGS OR PIPING UNTIL THE FOLLOWING ITEMS ARE SIGNED OFF.
- 2) ALL-WEATHER EMERGENCY ACCESS ROADWAYS AND FIRE HYDRANTS (IN SERVICE) SHALL BE PROVIDED PRIOR TO ANY COMBUSTIBLE CONSTRUCTION OR STORAGE ON SITE.

SITE

INSPECTIONS	INITIALS	DATE
→ UNDERGROUND WATER MAINS/THRUST BLOCKS		
→ HYDROSTATIC TEST OF WATER MAINS		
FLUSHING OF WATER MAINS		
REFLECTIVE MARKERS		
PAINTING OF EQUIPMENT		
MARKING OF FIRE LANES		
ADDRESS POSTED		
EMERGENCY ACCESS KEY BOX (KNOX)		
FIRE HYDRANTS		

FIRE & LIFE SAFETY

EXITING SYSTEMS		
FIRE DOORS		
SMOKE VENTING		
HIGH PILED STOCK		
FLAMMABLE LIQUIDS		
HAZARDOUS MATERIALS		
SPECIAL HAZARDS		
INTERIOR FINISH		
POSTED SIGNS FOR OCCUPANT LOAD		

EQUIPMENT

→ FIRE SPRINKLER WELDED OUTLETS		
→ FIRE SPRINKLER SYSTEM PIPING	<u>PR</u>	<u>4/13/99</u>
→ FIRE SPRINKLER HYDROSTATIC TEST	<u>PR</u>	<u>4/13/99</u>
→ STANDPIPES		
→ FIRE ALARMS/TESTING CONTRACT		
KITCHEN HOOD & DUCT SYSTEM		
SPECIAL EXTINGUISHING SYSTEM		
FIRE EXTINGUISHERS		
PRIVATE WATER SYSTEM		

SPECIAL REQUIREMENTS

FINAL APPROVAL

APPROVED FIRE FLOW	<u>PR</u>	<u>4/13/99</u>
OCCUPANCY GRANTED/F.D. APPROVAL		

NOTICE:
FAILURE TO COMPLY WITH AN ORDER OF THE FIRE DEPARTMENT MAY RESULT IN THE ISSUANCE OF A CITATION AND/OR DISCONTINUED USE OF THE BUILDING OR PREMISES.
1994 UFC SECTIONS 103.4.3.1, 103.4.3.2, 103.4.4.

**KEEP THIS CARD FOR REFERENCE
THIS IS YOUR RECORD OF FIELD INSPECTIONS**

Order to Lim/cc

04/16/1999 04:00 JRB
DATE: 04/16/1999 3:47PM 00005103
SHT COM BLDG PT
0201BLDG PMT-COM/L
\$350.00
0259TECH BURCHARGE \$0.36
PC
CHANGE \$0.00

**CITY OF SACRAMENTO
DAY TEMPORARY CERTIFICATE OF OCCUPANCY**

30 For Information Contact (916) 264-7619

Building Address 3200 STOCKTON BLVD. Permit No. 98-07171

Building Use New Building DBA: Fruiteridge Printing Occupancy F1

Building Owner Fruiteridge Printing Construction Type VN

Owner Address 3258 Stockton Blvd, Sacto., CA Sprinkled (X) Yes () No

Portion of Building Occupied 100% for purpose of installing equipment for business operation Area 6220 Sq. Ft.

04/16/99 05/16/99 DENNIS RICHARDSON *Dennis Richardson* **XXXXXXXXXXXXXXXXXXXX** City Building Official

Date Issued 04/16/99 Expiration Date 05/16/99 Sign Dennis Richardson
Wilhelm/Wagner/Rodgers/Spiross/Robles
CBC109.4 TEMPORARY CERTIFICATE

If the Chief Building Official finds that no substantial hazard will result from occupancy of any building or portion thereof before the same is completed, a temporary Certificate of Occupancy may be issued for the use of a portion or portions of a building or structure prior to the completion for the entire building or structure.
City of Sacramento

POST IN A CONSPICUOUS PLACE APR 16 1999

NEIGHBORHOODS PLANNING
AND DEVELOPMENT SERVICES