

CITY OF SACRAMENTO
1231 I Street, Sacramento, CA 95814

Permit No: 9909016
Insp Area: 4

Site Address: 55 DRAWBRIDGE CT SAC
Parcel No: 274-0520-010 RIVERWALK LOT 45

Sub-Type: NSFR
Housing (Y/N): N

CONTRACTOR
MYERS HOMES INC.
3300 FITZGERALD RD.
RANCHO CORDOVA CA. 95742

OWNER

ARCHITECT

Nature of Work: MP 1582 1 STORY 7 ROOM SFR

CONSTRUCTION LENDING AGENCY : I hereby affirm under penalty of perjury that there is a construction lending agency for the performance of the work for which this permit is issued (Sec. 3097, Civ. C).

Lender's Name _____ Lender's Address _____

LICENSED CONTRACTORS DECLARATION: I hereby affirm under penalty of perjury that I am licensed under provisions of Chapter 9 (commencing with section 7000) of Division 3 of the Business and Professions Code and my license is in full force and effect.

License Class 80 License Number 744475 Date 9-17-99 Contractor Signature R. Stewart

OWNER-BUILDER DECLARATION: I hereby affirm under penalty of perjury that I am exempt from the contractors License Law for the following reason (Sec. 7031.5, Business and Professions Code; any city or county which requires a permit to construct, alter, improve, demolish, or repair any structure, prior to its issuance, also requires the applicant for such permit to file a signed statement that he or she is licensed pursuant to the provisions of the Contractors License Law (Chapter 9 (commencing with Section 7000) of Division 8 of the Business and Professions Code) or that he or she is exempt therefrom and the basis for the alleged exemption. Any violation of Section 7031.5 by any applicant for a permit subjects the applicant to a civil penalty of not more than five hundred dollars (\$500.00).

I, _____, as a owner of the property, or my employees with wages as their sole compensation, will do the work, and the structure is not intended or offered for sale (Sec. 7044, Business and Professional Code: The Contractors License Law does not apply to an owner of property who builds or improves thereon, and who does such work himself or herself or through his/her own employees, provided that such improvements are not intended or offered for sale. If, however, the building or improvement is sold within one year of completion, the owner-builder will have the burden of proving that he/she did not build or improve for the purpose of sale.)

I, _____, as owner of the property, am exclusively contracting with licensed contractors to construct the project (Sec. 7044, Business and Professions Code: The Contractors License Law does not apply to an owner of property who builds or improves thereon, and who contracts for such projects with a contractor(s) licensed pursuant to the Contractors License Law).

I am exempt under Sec. _____ B & PC for this reason: _____

Date _____ Owner Signature _____

IN ISSUING THIS BUILDING PERMIT, the applicant represents, and the city relies on the representation of the applicant, that the applicant verified all measurements and locations shown on the application or accompanying drawings and that the improvement to be constructed does not violate any law or private agreement relating to permissible or prohibited locations for such improvements. This building permit does not authorize any illegal location of any improvement or the violation of any private agreement relating to location of improvements.

I certify that I have read this application and state that all information is correct. I agree to comply with all city and county ordinances and state laws relating to building construction and hereby authorize representative(s) of this city to enter upon the abovementioned property for inspection purposes.

Date 9-17-99 Applicant/Agent Signature R. Stewart

WORKER'S COMPENSATION DECLARATION: I hereby affirm under penalty of perjury one of the following declarations:

I have and will maintain a certificate of consent to self-insure for workers' compensation as provided for by Section 3700 of the Labor Code, for the performance of work for which the permit is issued.

I have and will maintain workers' compensation insurance, as required by Section 3700 of the Labor Code, for the performance of the work for which this permit is issued. My workers' compensation insurance carrier and policy number are:

Carrier RELiance NAT INS CO Policy Number NWAO154613 Exp Date 04/01/2000

(This section need not be completed if the permit is for \$100 or less) I certify that in the performance of the work for which this permit is issued, I shall not employ any person in any manner so as to become subject to the workers' compensation laws of California and agree that if I should become subject to the workers' compensation provisions of Section 3700 of the Labor Code, I shall forthwith comply with those provisions.

Date 9-17-99 Applicant Signature R. Stewart

WARNING - FAILURE TO SECURE WORKER'S COMPENSATION COVERAGE IS UNLAWFUL AND SHALL SUBJECT AN EMPLOYER TO CRIMINAL PENALTIES AND CIVIL FINES UP TO ONE HUNDRED THOUSAND DOLLARS (\$100,000) IN ADDITION TO THE COST OF COMPENSATION, DAMAGES AS PROVIDED FOR IN SECTION 3706 OF THE LABOR CODE, INTEREST AND ATTORNEY'S FEE.

THIS PERMIT SHALL EXPIRE BY LIMITATION IF WORK IS NOT COMMENCED WITHIN 180 DAYS.

OMEGA PRODUCTS CORP.
GLASS BLOCK INSULATING STUCCO SYSTEM

JOB ADDRESS:

55 Drawbridge Ct

ICED Report #4804

Date of Job Completion 1-20-00

PLASTERING CONTRACTOR:

Name: Norscal Plastering

Address: Box 355 Lincoln Ca 95648

Telephone No: (916) 645-7337

Contractor Number of Stucco Wall System 2130

This is to certify that the exterior coating system on the building exterior at the above address has been installed in accordance with the evaluation report specified above and the manufacturer's instructions.

Date

Jim Buestin
Signature of authorized representative of
Plastering Contractor

This installation card must be presented to the building inspector after completion of work and before final inspection.

PLAN 1, LOT 45
RESIDENTIAL BUILDING PERMIT APPLICATION

- New Construction Addition Remodels Other

Project Address: 55 DRAWBRIDGE CT. Assessor Parcel # 274-0520-010

OWNER INFORMATION:

Legal Property Owner: MYERS HOMES OF CALIFORNIA, LLC Phone # 916-851-0530
 Owner Address: 3300 FITZGERALD RD CITY RANCHO COORDINA State CA Zip 95742

CONTRACTOR INFORMATION:

Contractor: MYERS HOMES, INC. Lic. # 744473 Phone # 916-851-0530 Fax # 916-851-0535

PROJECT INFORMATION:

Land Use Zone R-1A PUD Occupancy Group R-3 Construction Type YN Fed Code 1A
 No. of stories: 1 No. of rooms: 10 Street width: 50 FT
 1st Floor Area 1582 2nd Floor Area N/A Basement N/A Roof Material TILE

AREA IN SQUARE FOOT OF:	EXISTING	NEW
Dwelling/Living	_____	<u>1582</u>
Garage/Storage	_____	<u>381</u>
Decks/Balconies	_____	<u>51</u>
Carports	_____	<u>—</u>

COVERED FRONT PORCH

SCOPE OF WORK: NEW CONSTRUCTION OF SINGLE FAMILY RESIDENCE; RIVERWALK
SERIES I PLAN 1 / 1582 sq ft IN MASTER PLANNED COMMUNITY P99-075
P17-005 AMENDED

FOR OFFICE USE ONLY:

- | | | |
|---|---|---|
| <input type="checkbox"/> Information above complete | <input type="checkbox"/> AR Flood Waiver required | <input type="checkbox"/> Planning Approval |
| <input type="checkbox"/> Violation files checked | <input type="checkbox"/> Flood Elevation Certificate Required | <input type="checkbox"/> Design Review Approval |
| <input type="checkbox"/> Standard setbacks | <input type="checkbox"/> Water Development Infill Area | <input type="checkbox"/> Special Fee Districts Apply: _____ |
| <input type="checkbox"/> County Sewer | | |

NEW STRUCTURES & ADDITIONS

- *THE FOLLOWING MUST BE PROVIDED IN ORDER TO SUBMIT FOR PLAN REVIEW
- Plot 8.5' x 11' DRAINAGE INFO*
- 2 COMPLETE PLANS, LEGIBLE & DRAWN TO SCALE Plans to include: site plan, floor plan, elevations, roof/ceiling plan, foundation and structural framing details, and structural calculations for non-conforming structures.
- 3 SETS IF PROJECT IS IN A DESIGN REVIEW AREA
- Title 24 Energy Compliance documentation 11" x 17" copy of floor plan for County Assessor
- Grading and Erosion Control Questionnaire Plan Review Fees

Date: _____ Received by: (staff) _____

ACTIVITY/PERMIT #

CERTIFICATION OF INSULATION

MEYERS

LOT # 45

- P.O. BOX 854, WEST SACRAMENTO, CA 95691 LIC. #202026
- 1309 MELODY ROAD, MARYSVILLE, CA 95901 LIC. #202026
- P.O. BOX 9651, FRESNO, CA 93793-9651 LIC. #202026
- P.O. BOX 1631, RENO, NV 89505 LIC. #10675
- 3326 A PONDEROSA WAY, LAS VEGAS, NV 89118 LIC. #10675

Riverwalk SERIES I

DATE INSULATION COMPLETED

GENERAL PART II AREAS INSULATED

WALLS	CEILINGS	FLOORS
(SQUARE FEET)	(SQUARE FEET)	(SQUARE FEET)
TYPE OF INSULATION	TYPE OF INSULATION	TYPE OF INSULATION
MATERIAL FIBERGLASS	MATERIAL FIBERGLASS	MATERIAL FIBERGLASS
FORM BATTS	FORM BATTS & BLOW	FORM BATTS
MANUFACTURER'S PRODUCT I D	MANUFACTURER'S PRODUCT I D	MANUFACTURER'S PRODUCT I D
MANUFACTURER	MANUFACTURER	MANUFACTURER
OCF	OCF	OCF
	BAGS	
R-VALUE INSTALLED	APPLIED THICKNESS	R-VALUE INSTALLED
13	35 1/8"	30
		30
		9"
		12"
		MIN. INSTALLED WEIGHT PER SQUARE FOOT
		APPLIED THICKNESS

KNEE WALLS IF R-VALUE IS OTHER THAN WALLS ABOVE

MATERIAL FIBERGLASS	FORM BATTS	R VALUE	MANUFACTURER OCF
----------------------------	-------------------	---------	-------------------------

AIR INFILTRATION SEALANT

MATERIAL FOAM	MANUFACTURER W R GRACE
----------------------	-------------------------------

THIS IS TO CERTIFY THAT INSULATION AND/OR SEALANT HAS BEEN INSTALLED IN CONFORMANCE WITH APPLICABLE CODES MATERIAL STANDARDS AND REGULATIONS.

SIGNATURE - INSULATION CONTRACTOR	TITLE MANAGER	DATE 1-13-00
SIGNATURE - GENERAL CONTRACTOR	TITLE	DATE

REMARKS

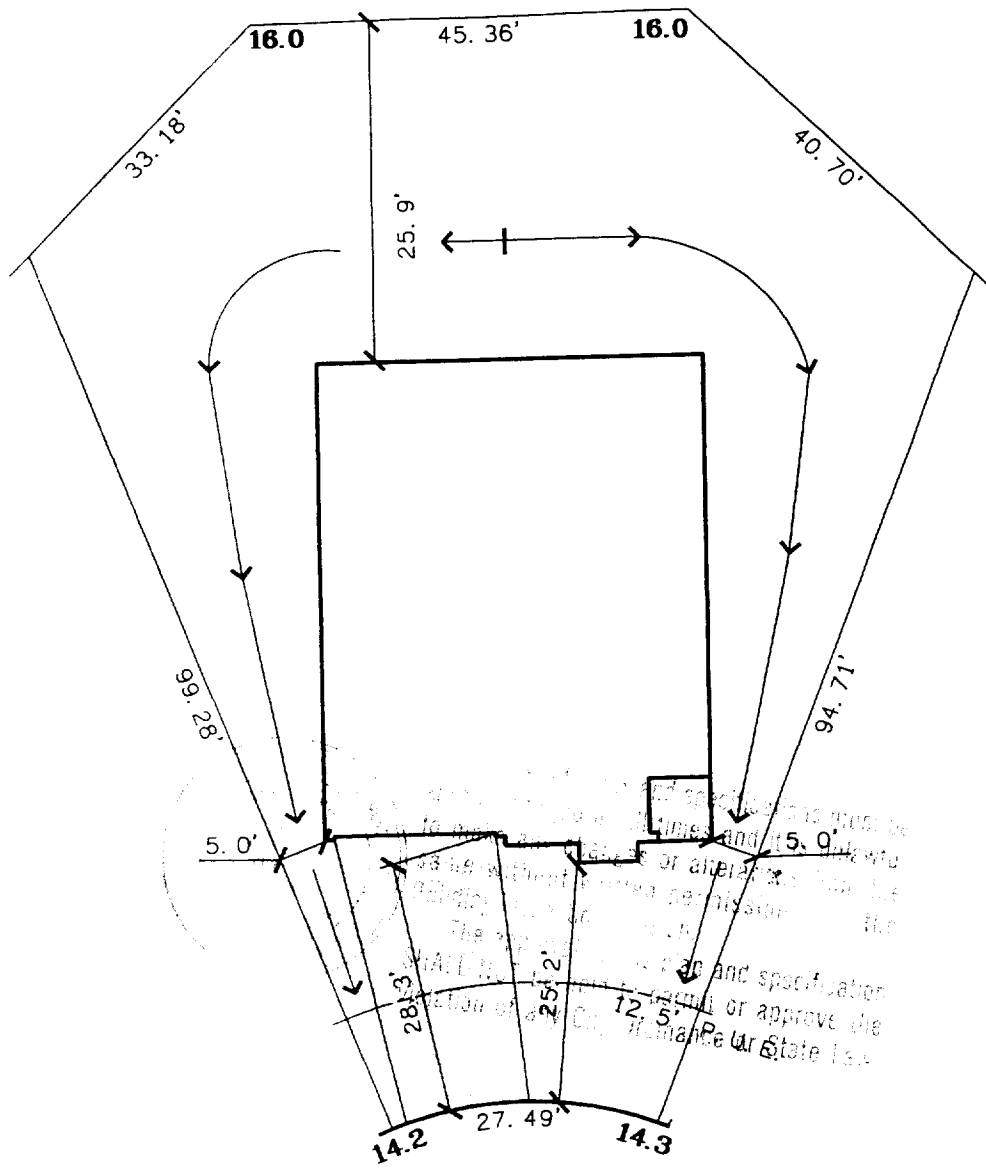

DRAWBRIDGE COURT

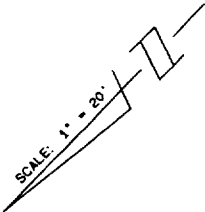

DATE: 8-4-99
 A.P.N.:
 ADDRESS: 55 DRAWBRIDGE COURT

LOT AREA: 7,469 SF
 LOT COVERAGE: 26%

The Spink Corporation
 2590 VENTURE OAKS WAY
 SACRAMENTO, CA. 95833
 PH:(916)925-5550 FAX:(916)921-9274

**RIVERWALK
 UNIT NO. 1
 LOT 45
 PLAN 1582C**

RIVERWALK
 CITY OF SACRAMENTO, CA.
 CLIENT: MYERS HOMES
 JOB NO.: 1456-001

CAMINO STATION

ROAD A

RIVERWALK

TWO RIVERS

RIVERWALK PARK
3.0FAC.

ELEMENTARY SCHOOL

WEST RIVER

WATERS EDGE

DRAINAGE

WEST EL CAMINO AVE

FUTURE COMMERCIAL

UNITY PARK

VILLAGE

UNITY WAY

LEROY GREENE MIDDLE SCHOOL (EXISTING)

SANITARY SEWER

32000