

CITY OF SACRAMENTO
1231 I Street, Sacramento, CA 95814

Permit No: 0401444

Insp Area: 4

Thos Bros:

Sub-Type: REP

N

Site Address: 2727 RIVER PLAZA DR SAC

Parcel No: APT # 150

Housing (Y/N):

CONTRACTOR

OWNER

SFC RIVERVIEW RANCH INVESTORS ET AL
800 AIRPORT BLVD STE 502
BURLINGAME CA 94010

ARCHITECT

Nature of Work: REPAIR/REPLACE (MATCH EXISTING) FAILING STAIRS

CONSTRUCTION LENDING AGENCY : I hereby affirm under penalty of perjury that there is a construction lending agency for the performance of the work for which this permit is issued (Sec. 3097, Civ. C).

Lender's Name _____ Lender's Address _____

LICENSED CONTRACTORS DECLARATION: I hereby affirm under penalty of perjury that I am licensed under provisions of Chapter 9 (commencing with section 7000) of Division 3 of the Business and Professions Code and my license is in full force and effect.

License Class _____ License Number _____ Date _____ Contractor Signature _____

OWNER-BUILDER DECLARATION: I hereby affirm under penalty of perjury that I am exempt from the contractors License Law for the following reason (Sec. 7031.5, Business and Professions Code; any city or county which requires a permit to construct, alter, improve, demolish, or repair any structure, prior to its issuance, also requires the applicant for such permit to file a signed statement that he or she is licensed pursuant to the provisions of the Contractors License Law (Chapter 9 (commencing with Section 7000) of Division 8 of the Business and Professions Code) or that he or she is exempt therefrom and the basis for the alleged exemption. Any violation of Section 7031.5 by any applicant for a permit subjects the applicant to a civil penalty of not more than five hundred dollars (\$500.00);

_____, I, as a owner of the property, or my employees with wages as their sole compensation, will do the work, and the structure is not intended or offered for sale (Sec. 7044, Business and Professional Code: The Contractors License Law does not apply to an owner of property who builds or improves thereon, and who does such work himself or herself or through his/her own employees, provided that such improvements are not intended or offered for sale. If, however, the building or improvement is sold within one year of completion, the owner-builder will have the burden of proving that he/she did not build or improve for the purpose of sale.)

JCM, as owner of the property, am exclusively contracting with licensed contractors to construct the project (Sec. 7044, Business and Professions Code: The Contractors License Law does not apply to an owner of property who builds or improves thereon, and who contracts for such projects with a contractor(s) licensed pursuant to the Contractors License Law).

_____, I am exempt under Sec. _____ B & PC for this reason: _____

Date 2/4/04 Owner Signature J.C. Mooney

PAID

IN ISSUING THIS BUILDING PERMIT, the applicant represents, and the city relies on the representation of the applicant, that the applicant verified all measurements and locations shown on the application or accompanying drawings and that the improvement to be constructed does not violate any law or private agreement relating to permissible or prohibited locations for such improvements. This building permit does not authorize any illegal location of any improvement or the violation of any private agreement relating to location of improvements.

CITY OF SACRAMENTO
NORTH PERMIT

I certify that I have read this application and state that all information is correct. I agree to comply with all city and county ordinances and state laws relating to building construction and hereby authorize representative(s) of this city to enter upon the abovementioned property for inspection purposes.

Date 2/4/04 Applicant/Agent Signature J.C. Mooney

WORKER'S COMPENSATION DECLARATION: I hereby affirm under penalty of perjury one of the following declarations:

_____, I have and will maintain a certificate of consent to self-insure for workers' compensation as provided for by Section 3700 of the Labor Code, for the performance of work for which the permit is issued.

JCM have and will maintain workers' compensation insurance, as required by Section 3700 of the Labor Code, for the performance of the work for which this permit is issued. My workers' compensation insurance carrier and policy number are:

Carrier

Policy Number

Exp Date

_____, (This section need not be completed if the permit is for \$100 or less) I certify that in the performance of the work for which this permit is issued, I shall not employ any person in any manner so as to become subject to the workers' compensation laws of California and agree that if I should become subject to the workers' compensation provisions of Section 3700 of the Labor Code, I shall forthwith comply with those provisions.

Date 2/4/04 Applicant Signature J.C. Mooney

WARNING: FAILURE TO SECURE WORKER'S COMPENSATION COVERAGE IS UNLAWFUL AND SHALL SUBJECT AN EMPLOYER TO CRIMINAL PENALTIES AND CIVIL FINES UP TO ONE HUNDRED THOUSAND DOLLARS (\$100,000) IN ADDITION TO THE COST OF COMPENSATION, DAMAGES AS PROVIDED FOR IN SECTION 3706 OF THE LABOR CODE, INTEREST AND ATTORNEY'S FEE.

THIS PERMIT SHALL EXPIRE BY LIMITATION IF WORK IS NOT COMMENCED WITHIN 180 DAYS.

APPLICATION FOR COMMERCIAL BUILDING PERMIT

CITY OF SACRAMENTO
PLANNING & BUILDING DEPARTMENT
 1231 I Street, Suite 200 or 2101 Arena Bl., 200
 Sacramento, CA 95814 Sacramento, CA 95834
 (916) 264-5656, 1-866 EZ PERMIT or www.cityofsacramento.org

ACTIVITY #	Insp. Area
-------------------	-------------------

Applicant to complete all areas down to valuation

ADDRESS 2727 River Plaza Dr., Sacramento, CA 95833 Suite 150
PARCEL # _____

CONTACT		LICENSED CONTRACTOR Lic No. # _____	
Name <u>Greg DeFehr</u>	Street Address <u>1175 Lake Blvd.</u>	Name _____	Address _____
City/State/Zip <u>Davis, CA 95616</u>	Phone <u>(530) 400-0842</u> FAX <u>(530) 756-5689</u>	City/State/Zip _____	Phone _____ FAX _____
E-mail: _____		E-mail: _____	
ARCHITECT/ENGINEER		OWNER	
Name _____	Address _____	Name <u>Stonesfair Management</u>	Address <u>800 Airport Blvd. Suite 502</u>
City/State/Zip _____	Phone _____ FAX _____	City/State/Zip <u>Burlingame, CA 94010</u>	Phone <u>(650) 401-3810</u> FAX <u>(650) 342-2836</u>
E-mail: _____		E-mail: _____	

→ Will permittee have any employees on the jobsite? No Yes → **INSURANCE CO:** State Fund
 → **WORKER'S COMPENSATION POLICY #** 1619331-02 **EXPIRATION DATE:** February 1, 2004

NATURE OF WORK IN DETAIL: Repair or replace failing stairs. One stair
See attached detail.

OCCUPANT/TENANT: _____ **VALUATION:** \$ 5,500.00

FLOOD STATUS						S.C.A.T.								
JOB DESCRIPTION						BLDG <input type="checkbox"/>	SHELL <input type="checkbox"/>	APT <input type="checkbox"/>	TI () <input type="checkbox"/>	REM () <input type="checkbox"/>	SW <input type="checkbox"/>	FIRE <input type="checkbox"/>	ADD <input type="checkbox"/>	OTHER <input type="checkbox"/>
INSPECTION DISCIPLINES						BLDG	MECH	PLUMB	ELEC	SITE	FIRE			
# Stories	1 st flr Area.	Total Area	Use Zone	Occp Group	Const type	Fire Req. Y/N		Fed Code		Vio. File				
						SPR	ALARM					PW	UTIL	
B	L	P	M	E	F	S		D						

COMMENTS:

REGIONAL SANITATION FEES? Yes No **HEALTH DEPARTMENT?** Yes No
WATER FLOW TEST FOR NEW BUILDINGS OR ADDITIONS? Yes No

STONESFAIR MANAGEMENT, LLC

February 12, 2003

Sacramento City Building Permit Department
City and County of Sacramento

Dear Sir or Madam:

This letter serves as confirmation that the following employee, Greg DeFehr is employed with our Company. Greg DeFehr is our designated Project Manager responsible for bids, contracts, capital improvements and deferred maintenance to all of our Sacramento properties. Mr. DeFehr has full authorization in requesting for permits within the Stonesfair Management portfolio. Please do not hesitate to call if you need further information.

Sincerely,



Maryann Fair
Vice President

800 Airport Boulevard, Suite 502, Burlingame, California 94010 (650) 401-3810 FAX (650) 342-2836

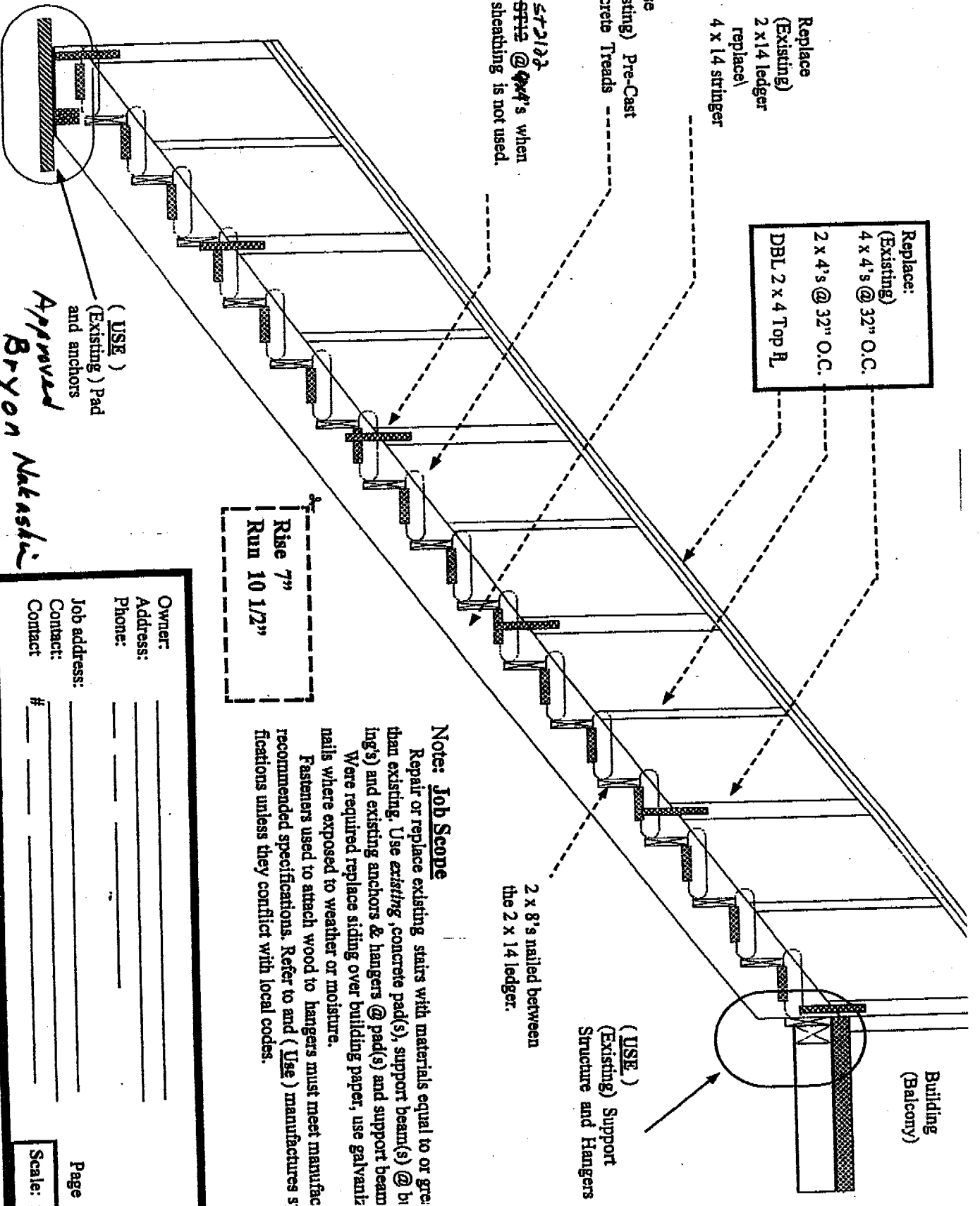

Provide: *STAIRS*
 Simpson 5512 @ 4's when
 plywood sheathing is not used.

Replace
 (Existing)
 2 x 14 Ledger
 replace
 4 x 14 stringer

Replace:
 (Existing)
 4 x 4's @ 32" O.C.
 2 x 4's @ 32" O.C.
 DBL 2 x 4 Top R.

Reuse
 (Existing) Pre-Cast
 Concrete Treads

(USE)
 (Existing) Support
 Structure and Hangers

2 x 8's nailed between
 the 2 x 14 ledger.

Rise 7"
 Run 10 1/2"

Note: Job Scope
 Repair or replace existing stairs with materials equal to or greater than existing. Use existing, concrete pad(s), support beam(s) @ bling(s) and existing anchors & hangers @ pad(s) and support beam. Where required replace siding over building paper, use galvanized nails where exposed to weather or moisture. Fasteners used to attach wood to hangers must meet manufacturer's recommended specifications. Refer to and (USE) manufacturer's specifications unless they conflict with local codes.

(USE)
 (Existing) Pad
 and anchors
 Approved
 Bryon Nataskie

Owner:	_____	Page
Address:	_____	Scale: 1
Phone:	_____	
Job address:	_____	
Contact:	_____	
Contact #:	_____	

Extend the post bottom
12" past the plane of the
the plane of the

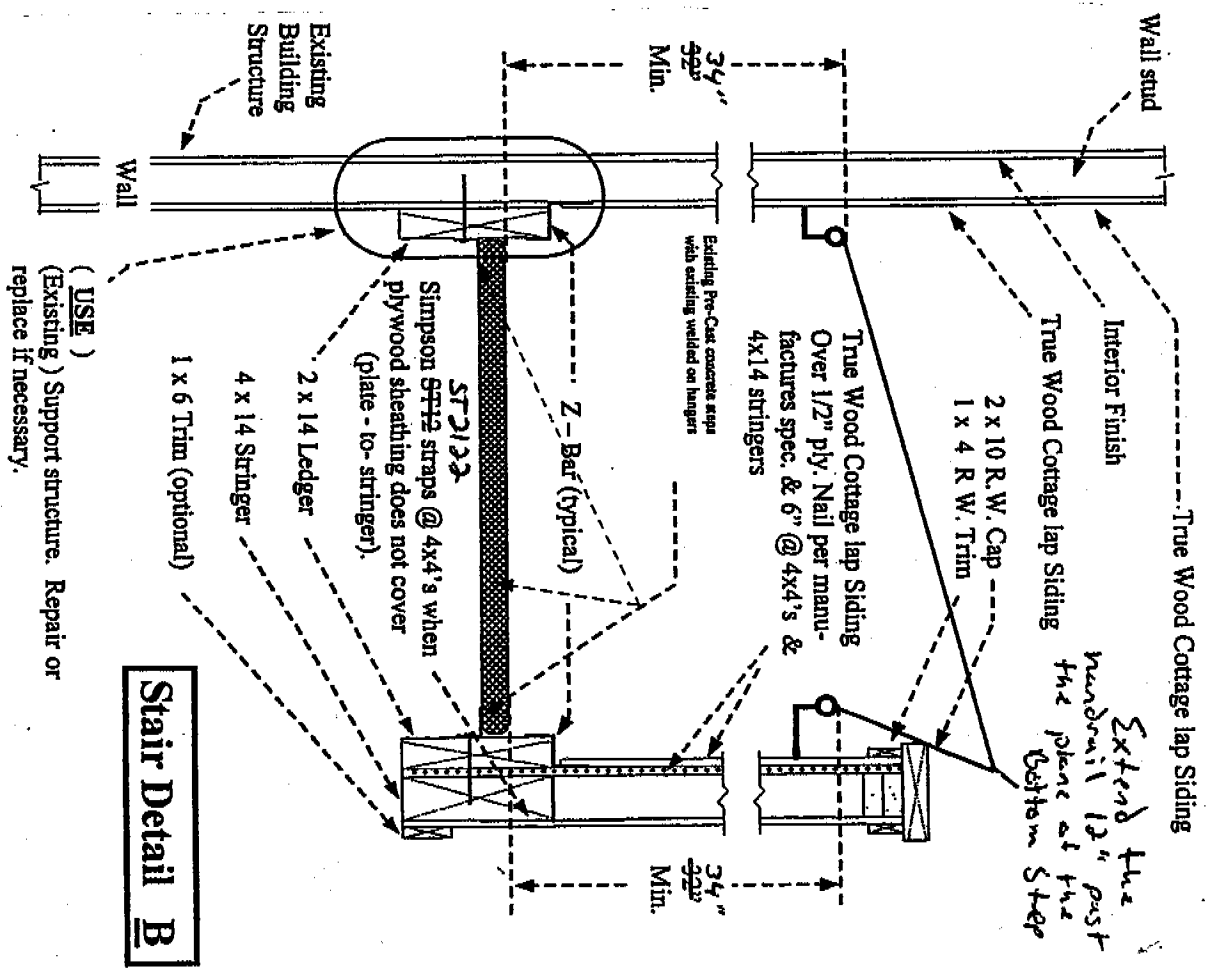
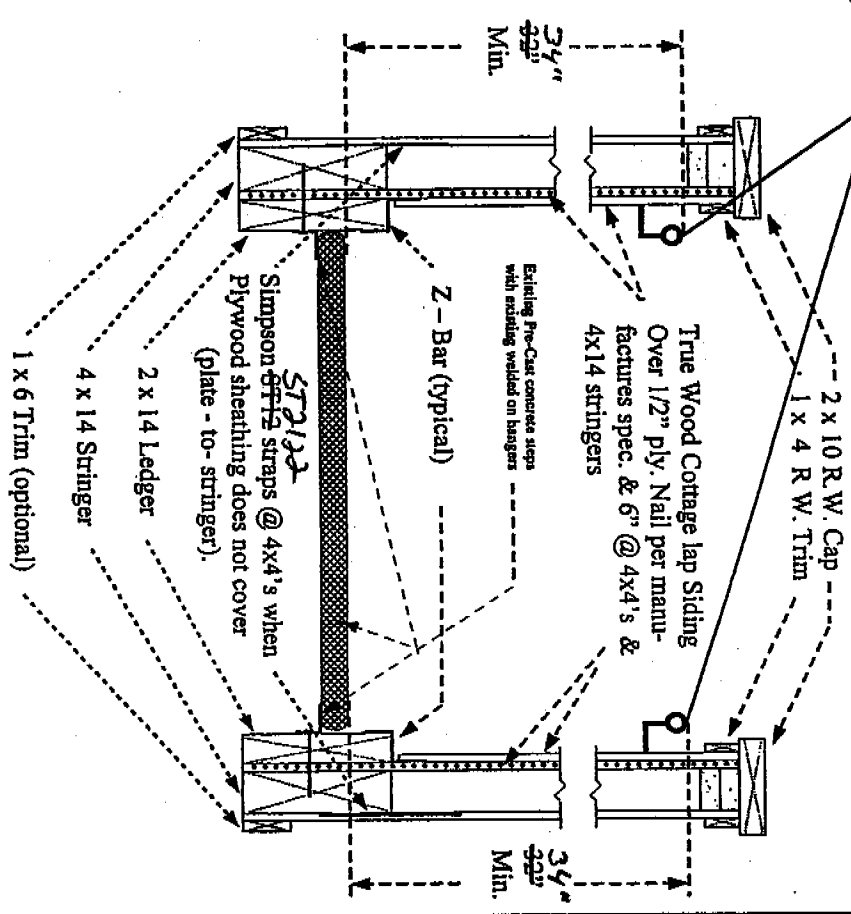

Stair Detail A

Stair Detail B

Owner: _____

Address: _____

Phone: _____

Job address: _____

Contact: _____

Contact: _____

Page 2 of 2

Scale: no scale

FAX

Date

Number of pages including cover sheet

TO: Building Dept.
ATTN:

FROM:



Draeger Construction, Inc.
4641 Pell Drive, Suite 16
Sacramento, CA 95838

Phone

Fax Phone

800-8370

Phone

Fax Phone

916-646-6400

916-646-6457

RE: FINAL Insp.

REMARKS:

Urgent

For your review

Reply ASAP

Please Comment

enclosed are 11 total
Permit #'s please schedule
for inspection on 6-11-04
Please contact me directly
PAUL KOUARCHUK
1916 275-4667

P.S. Inspections are ALL
in one complex