

CONSTRUCTION LENDING AGENCY

I hereby affirm under penalty of perjury that there is a construction lending agency for the performance of the work for which this permit is issued (Sec. 3097, Civ. C).

Lenders Name _____
 Lenders Address _____

LICENSED CONTRACTORS DECLARATION

I hereby affirm under penalty of perjury that I am licensed under provisions of Chapter 9 (commencing with Section 7000) of Division 3 of the Business and Professions Code and my license is in full force and effect.

License Class C-45 Lic. Number A23432
 Date 12-14-98 Contractor Stal Sanchez
 (Signature)

OWNER - BUILDER DECLARATION

I hereby affirm under penalty of perjury that I am exempt from the Contractors License Law for the following reason (Sec. 7031.5, Business and Professions Code: Any city or county which requires a permit to construct, alter, improve, demolish, or repair any structure, prior to its issuance, also requires the applicant for such permit to file a signed statement that he or she is licensed pursuant to the provisions of the Contractors License Law (Chapter 9 (commencing with Section 7000) of Division 3 of the Business and Professions Code) or that he or she is exempt therefrom and the basis for the alleged exemption. Any violation of Section 7031.5 by any applicant for a permit subjects the applicant to a civil penalty of not more than five hundred dollars (\$500.00):

I, as owner of the property, or my employees with wages as their sole compensation, will do the work, and the structure is not intended or offered for sale (Sec. 7044, Business and Professions Code: The Contractors License Law does not apply to an owner of property who builds or improves thereon, and who does such work himself or herself or through his or her own employees, provided that such improvements are not intended or offered for sale. If, however, the building or improvement is sold within one year of completion, the owner-builder will have the burden of proving that he or she did not build or improve for the purpose of sale.)

I, as owner of the property, an exclusively contracting with licensed contractors to construct the project (Sec. 7044, Business and Professions Code: The Contractors License Law does not apply to an owner of property who builds or improves thereon, and who contracts for such projects with a contractor(s) licensed pursuant to the Contractors License Law).

I am exempt under Sec. _____ B & P Code for this reason _____
 Date 12/14/98 Owner Stal Sanchez
 (Signature)

In issuing this building permit, the applicant represents, and the City relies on the representation of the applicant, that the applicant verified all measurements and locations shown on the application or accompanying drawings and that the improvement to be constructed does not violate any law or private agreement relating to permissible or prohibited locations for such improvements. This building permit does not authorize any illegal location of any improvement or the violation of any private agreement relating to location of improvements.

I certify that I have read this application and state that all information is correct. I agree to comply with all city and county ordinances and state laws relating to building construction and hereby authorize representative of this city to enter upon the abovementioned property for inspection purposes.

Date 12-14-98 Signature of Applicant or Agent Stal Sanchez

SITE ADDRESS

2809 1st (2815)

ASSESSOR PARCEL NO.

007-0044-023

PERMIT NO.

9812657

NAME OF APPLICANT

ADVANCE

ADDRESS

2119 SULLERS WAY

LICENSED CONTRACTOR BUSINESS OWNER

ADVANCE

ZIP CODE

94691

PHONE NO.

736-9000

SIGN INFORMATION

- ATTACHED INTERIOR / ELECT. SINGLE FACED
- ILLUMINATED NON-ILLUMINATED BILLBOARD / SUBDIVISION
- INDIVIDUAL LETTERS PAINTED ON BUILDING LOGO
- METAL POLE DOUBLE FACED
- PLASTIC MONUMENT VINYL/GATOR FOAM
- WOODEN PROJECTING RE-FACE

SIGN COPY

ADVANCE TYPE PWS 1060

CITY OF SACRAMENTO

2015 = C-2

BUILDING INSPECTION DIVISION

PERMIT SERVICES
264-7619

WORKER'S COMPENSATION DECLARATION

I hereby affirm under penalty of perjury one of the following declarations:
 I have and will maintain a certificate of consent to self-insure for workers' compensation as provided for by Section 3700 of the Labor Code, for the performance of work for which the permit is issued.
 I have and will maintain workers' compensation insurance, as required by Section 3700 of the Labor Code, for the performance of the work for which this permit is issued. My workers' compensation insurance carrier and policy number are:
 Carrier STATE FUND
 Policy Number 1A55554-98

(This section need not be completed if the permit is for one hundred dollars (\$100) or less) I certify that in the performance of the work for which this permit is issued, I shall not employ any person in any manner so as to become subject to the workers' compensation laws of California and agree that if I should become subject to the workers' compensation provisions of Section 3700 of the Labor Code, I shall forthwith comply with those provisions.

Date: 12/14/98 Applicant Stal Sanchez
 (Signature)

WARNING: FAILURE TO SECURE WORKERS' COMPENSATION COVERAGE IS UNLAWFUL AND SHALL SUBJECT AN EMPLOYER TO CRIMINAL PENALTIES AND CIVIL FINES UP TO ONE HUNDRED THOUSAND DOLLARS (\$100,000); IN ADDITION TO THE COST OF COMPENSATION, DAMAGES AS PROVIDED FOR IN SECTION 3706 OF THE LABOR CODE, INTEREST AND ATTORNEY'S FEES.
 THIS PERMIT SHALL EXPIRE BY LIMITATION IF WORK AUTHORIZED IS NOT COMMENCED WITHIN 180 DAYS.

(A) HEIGHT 18" (B) LENGTH 13'-0"
 (A X B) SIGN AREA 20 SQ FT
 POLE SIZE _____ FOOTING SIZE _____
 STREET FRONTAGE (FT) _____
 OCCUPANCY FRONTAGE (FT) _____

ENGINEERING REQUIRED? YES NO
 DESIGN REVIEW REQUIRED? YES NO
 SPECIAL PERMIT REQUIRED? YES NO
 VARIANCE REQUIRED? YES NO
 LOCATED IN PUD? YES NO

OFFICE USE ONLY
 APPROVED BY LS
 DATE 12/24/98

SIGN VALUATION
 A. TYPE OF SIGN Attached SQ. FT. = \$
 B. \$ _____ PER SQ. FT. X _____ SQ. FT. = \$
 APPROVED BY MT DATE 12/24/98
 DENIED BY _____ DATE _____

FINAL INSPECTIONS
 BUILDING INSPECTOR _____ DATE _____
 ELECTRICAL INSPECTOR Wood DATE _____
 SIGN INSPECTOR _____ DATE _____

FEES:
 SIGN APPLICATION FEE 117.72
 SIGN PERMIT FEE 98.12657
 ELECTRICAL SIGN PERMIT FEE 117.72
 CITY BUSINESS LICENSE FEE 117.72
 OTHER _____
 TOTAL FEES \$ 117.72

S-20931

13'-0"

34"



Alliance Title

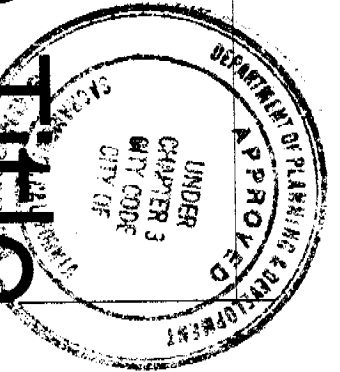

This sign MANUFACTURE AND INSTALL:
 kept on the ALLIANCE and ILLUMINATED CHANNEL LETTERS,
 to make any THE PLEX FACE MUST RETURN, BLACK TRIM CAP,
 some with UPPER AND LOWER CASE LETTERS.
 of Sacramento Sign Section permission from the City

EXTERIOR MANUFACTURE AND INSTALL:
 BLACK VINYL LETTERS ALLIANCE TITLE,
 20" x 20" x 20" UNILLUMINATED, BLACK TRIM CAP,
 LOGO - 25 1/2" x 20" UNILLUMINATED, BLACK TRIM CAP,
 BACK WITH 1/4" CLEAR PLEX TO MATCH BUSINESS CARD
 RECOMMENDED

ALL ELECTRICAL WORK MUST BE U.L. LABEL BY THE MANUFACTURER
 Standards, N.E.C. Sec. 90-6/ and comply with the City Code.
 EQUIPMENT MUST BE USED AS ALL SIGNAGE TO USE SAME FONT AS PER CUSTOMER'S
 REQUESTED
 ALL SIGN INSTALLATIONS ARE SUBJECT TO FIELD INSPECTION
 EXTERIOR Sign Concept

APPROVED 12-23-98
 12-23-98
 Jhu

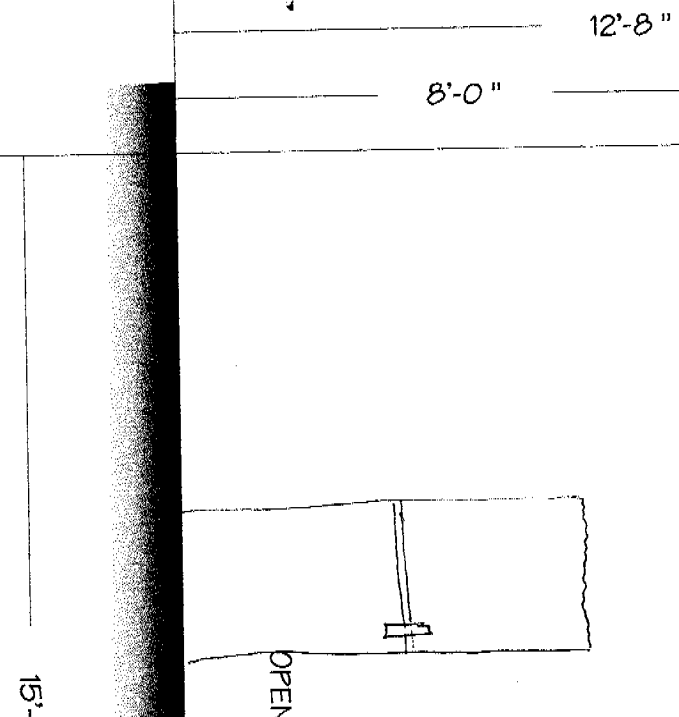
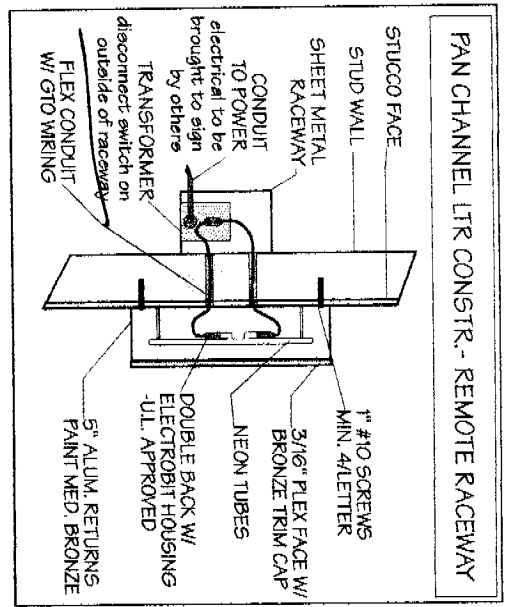

FILE COPY

2419 SELLERS WAY WEST SACRAMENTO (916) 371-3300 FAX 371-3755	
PROJECT NAME	ALLIANCE TITLE
ADDRESS	2815 J ST 2809 J ST. SACRAMENTO, CA 95816
SCALE	3/8" = 1'
DATE	12-8-98
SALESMAN	DAVID
DESIGNER	DUSTIN
JOB NUMBER	4686

28th

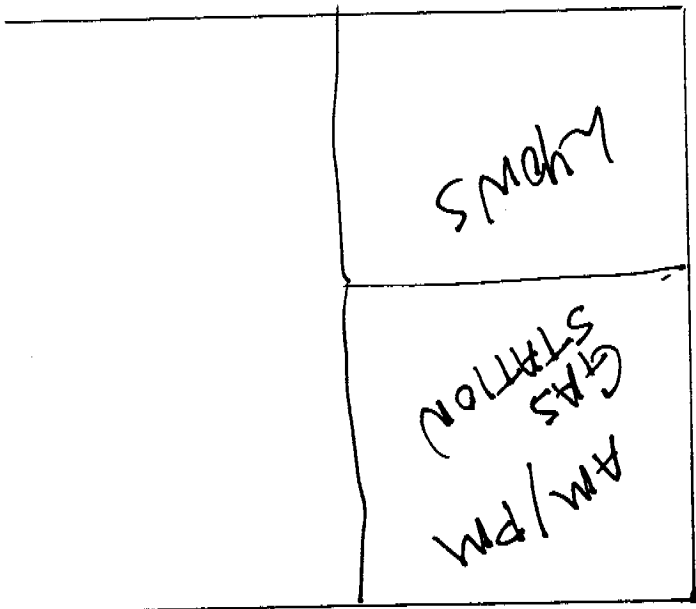
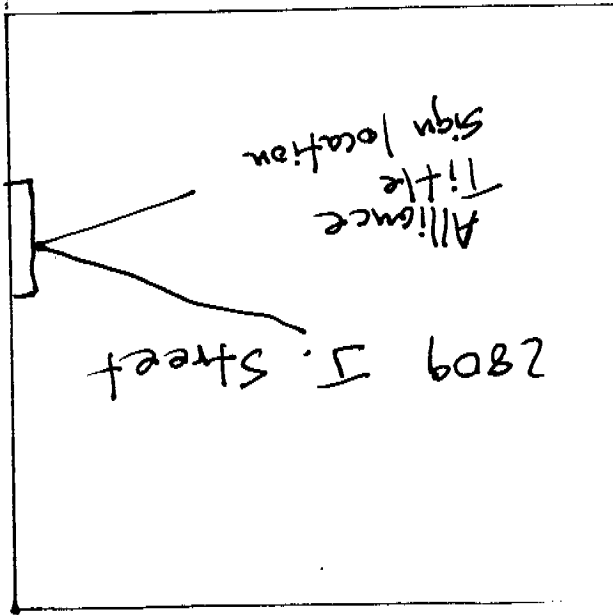

29th

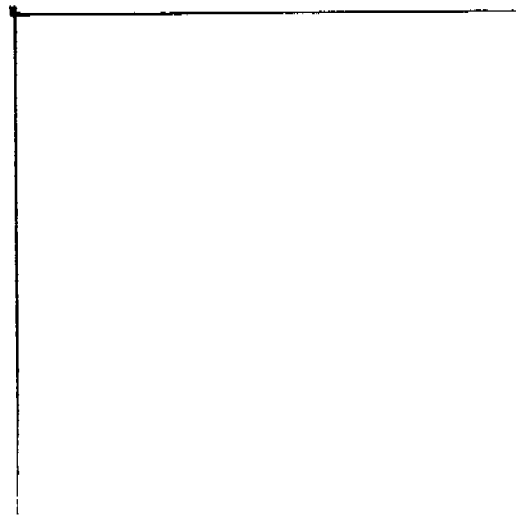

30' Frontage
 15' long 18" high lower cast
 upper 2'

10m

SITE PLAN
 ALLIANCE TITLE
 2809 JST

