

CITY OF SACRAMENTO

Permit No: 9807523

1231 I Street, Sacramento, CA 95814

Insp Area: 4

Site Address: 427 ARDEN WY SAC

Sub-Type: COM

Parcel No: 2750131014

Housing (Y/N): N

CONTRACTOR

BOSLEY ELECTRIC
427 ARDEN WY
SACRAMENTO CA

95813

OWNER

BOSLEY JOHN/NANCY
ELVERTA CA

95626

ARCHITECT

Nature of Work: RELOCATE SMUD MOTOR TO EXTERIOR OF BLDG.

CONSTRUCTION LENDING AGENCY: I hereby affirm under penalty of perjury that there is a construction lending agency for the performance of the work for which this permit is issued (Sec. 3097, Civ. C).

Lender's Name Lender's Address

LICENSED CONTRACTORS DECLARATION: I hereby affirm under penalty of perjury that I am licensed under provisions of Chapter 9 (commencing with section 7000) of Division 3 of the Business and Professions Code and my license is in full force and effect.

License Class B-C-10 License Number 379245 Date 8-5-98 Contractor Signature [Signature]

OWNER-BUILDER DECLARATION: I hereby affirm under penalty of perjury that I am exempt from the contractors License Law for the following reason (Sec. 7031.5, Business and Professions Code; any city or county which requires a permit to construct, alter, improve, demolish, or repair any structure, prior to its issuance, also requires the applicant for such permit to file a signed statement that he or she is licensed pursuant to the provisions of the Contractors License Law (Chapter 9 (commencing with Section 7000) of Division 8 of the Business and Professions Code) or that he or she is exempt therefrom and the basis for the alleged exemption. Any violation of Section 7031.5 by any applicant for a permit subjects the applicant to a civil penalty of not more than five hundred dollars (\$500.00);

I, as a owner of the property, or my employees with wages as their sole compensation, will do the work, and the structure is not intended or offered for sale (Sec. 7044, Business and Professional Code: The Contractors License Law does not apply to an owner of property who builds or improves thereon, and who does such work himself or herself or through his/her own employees, provided that such improvements are not intended or offered for sale. If, however, the building or improvement is sold within one year of completion, the owner-builder will have the burden of proving that he/she did not build or improve for the purpose of sale.)

I, as owner of the property, am exclusively contracting with licensed contractors to construct the project (Sec. 7044, Business and Professions Code: The Contractors License Law does not apply to an owner of property who builds or improves thereon, and who contracts for such projects with a contractor(s) licensed pursuant to the Contractors License Law).

I am exempt under Sec. B & PC for this reason:

Date Owner Signature

IN ISSUING THIS BUILDING PERMIT, the applicant represents, and the city relies on the representation of the applicant, that the applicant verified all measurements and locations shown on the application or accompanying drawings and that the improvement to be constructed does not violate any law or private agreement relating to permissible or prohibited locations for such improvements. This building permit does not authorize any illegal location of any improvement or the violation of any private agreement relating to location of improvements.

I certify that I have read this application and state that all information is correct. I agree to comply with all city and county ordinances and state laws relating to building construction and herby authorize representative(s) of this city to enter upon the abovementioned property for inspection purposes.

Date 8-5-98 Applicant/Agent Signature [Signature]

WORKER'S COMPENSATION DECLARATION: I hereby affirm under penalty of perjury one of the following declarations: I have and will maintain a certificate of consent to self-insure for workers' compensation as provided for by Section 3700 of the Labor Code, for the performance of work for which the permit is issued.

I have and will maintain workers' compensation insurance, as required by Section 3700 of the Labor Code, for the performance of the work for which this permit is issued. My workers' compensation insurance carrier and policy number are:

Carrier Maryland Casualty/Superior Nat. Policy Number WDN-38850-B

(This section need not be completed if the permit is for \$100 or less) I certify that in the performance of the work for which this permit is issued, I shall not employ any person in any manner so as to become subject to the workers' compensation laws of California and agree that if I should become subject to the workers' compensation provisions of Section 3700 of the Labor Code, I shall forthwith comply with those provisions.

Date 8-5-98 Applicant Signature [Signature]

WARNING: FAILURE TO SECURE WORKER'S COMPENSATION COVERAGE IS UNLAWFUL AND SHALL SUBJECT AN EMPLOYER TO CRIMINAL PENALTIES AND CIVIL FINES UP TO ONE HUNDRED THOUSAND DOLLARS (\$100,000) IN ADDITION TO THE COST OF COMPENSATION, DAMAGES AS PROVIDED FOR IN SECTION 3706 OF THE LABOR CODE, INTEREST AND ATTORNEY'S FEE.

THIS PERMIT SHALL EXPIRE BY LIMITATION IF WORK IS NOT COMMENCED WITHIN 180 DAYS.

Approval of all Electrical Work  
 subject to field inspections  
**98-7523C**

NOTE: NO NEW LOADS TO SERVICE

**ISSUED**

SEP 02 1998

CITY OF SACRAMENTO  
 DEVELOPMENT SERVICES DIV

NEW SMUD SECONDARY  
 CONDUCTORS LOWEST  
 ELEVATION +16'-0"

NEW WEATHER HEAD  
 SET AT +18'-0"  
 W/4-250AL

*3φ Δ  
 IDENTIFY Hi Leg  
 Orange &  
 Connect to 'B' ph.*

(N) 200 AMP METER/MAIN

(N) 1-2 1/2" C  
 W/ 4-#250AL

(E) METER TO REMOVE  
 (N) ELECTRICAL PANEL

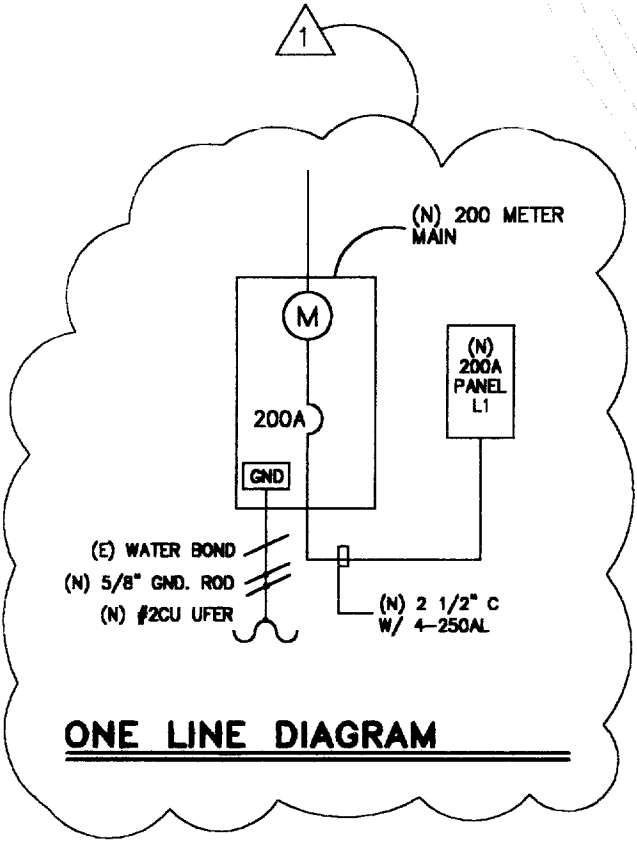

**RELOCATION OF METER MAIN**  
 427 ARDEN WAY SACRAMENTO CA.

1 REVISION PER CORRECTION NOTIC 8-24-98

**BOSLEY  
 ELECTRIC  
 COMPANY**

COMMERCIAL AND INDUSTRIAL  
 SERVICE AND CONTRACTING  
 P.O. BOX 1094 (916) 568-5180  
 Elverta, CA 95626 FAX (916) 568-5183  
 CA License No. 379245  
 NV License No. 0038979

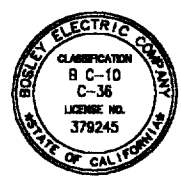

**E-1**

SCALE: NTS

ISSUED

AUG 25 1998

NOTE: NO NEW LOADS TO SERVICE

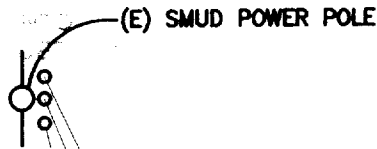

The approval of all Electrical Work is subject to field inspections

NEW SMUD SECONDARY CONDUCTORS LOWEST ELEVATION +16'-0"

APPROVED PER 1993  
 NATIONAL ELECTRICAL CODE  
 AND CITY OF SACRAMENTO  
 AMENDMENTS:  
8-5-98 *gm*  
 ELECTRICAL DIVISION

2 1/2" C  
(4) #250 AL  
Riser

NEW WEATHER HEAD SET AT +18'-0"

(N) 200 AMP METER/MAIN

2 1/2" C  
4- 250 MCM AL  
w/ #4cc GND  
@ (N) Service

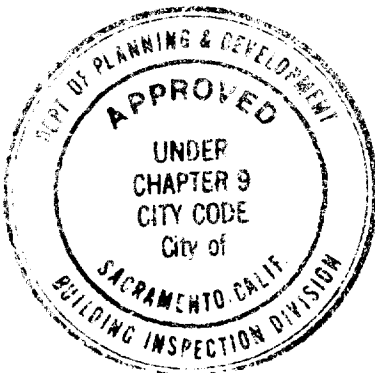

This set of plans and specifications must be kept on the job at all times and it is unlawful to make any changes or alterations from the same without written permission from the Building Inspection Division.

The approval of this plan and specification SHALL NOT be held to permit or approve the violation of any City Ordinance or State Law.

MW 1/2" x 8' Br Rod w/ #4 cu.  
#4 cu. to water

# RELOCATION OF METER MAIN

(No gas to Bld)

427 ARDEN WAY SACRAMENTO CA.

**BOSLEY  
ELECTRIC  
COMPANY**

COMMERCIAL AND INDUSTRIAL  
SERVICE AND CONTRACTING

P.O. BOX 1094 (916) 568-5180  
Elverta, CA 95626 FAX (916) 568-5183

CA License No. 379245  
NV License No. 0038979

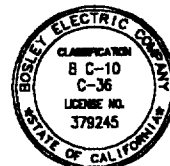

E-1

SCALE: NTS