

CITY OF SACRAMENTO

Permit No: 9807559

1231 I Street, Sacramento, CA 95814

Insp Area: 1

Site Address: 900 13TH ST SAC

Sub-Type: AOTHR

Parcel No: 0060052021

Housing (Y/N): N

CONTRACTOR
SATHY ELECTRIC
5714 FOLSOM BL
SACRAMENTO CA

95819

OWNER
PARKING AUTHORITY OFCITY OF SACRAMENTO
1231 J ST
SACRAMENTO CA

95814

ARCHITECT

Nature of Work: REMOVING&REPLACING ONE E.V. STATION

CONSTRUCTION LENDING AGENCY : I hereby affirm under penalty of perjury that there is a construction lending agency for the performance of the work for which this permit is issued (Sec. 3097, Civ. C).

Lender's Name Lender's Address

LICENSED CONTRACTORS DECLARATION: I hereby affirm under penalty of perjury that I am licensed under provisions of Chapter 9 (commencing with section 7000) of Division 3 of the Business and Professions Code and my license is in full force and effect.

License Class C-10 License Number 684827 Date 8/6/98 Contractor Signature

OWNER-BUILDER DECLARATION: I hereby affirm under penalty of perjury that I am exempt from the contractors License Law for the following reason (Sec. 7031.5, Business and Professions Code; any city or county which requires a permit to construct, alter, improve, demolish, or repair any structure, prior to its issuance, also requires the applicant for such permit to file a signed statement that he or she is licensed pursuant to the provisions of the Contractors License Law (Chapter 9 (commencing with Section 7000) of Division 8 of the Business and Professions Code) or that he or she is exempt therefrom and the basis for the alleged exemption. Any violation of Section 7031.5 by any applicant for a permit subjects the applicant to a civil penalty of not more than five hundred dollars (\$500.00);

I, as a owner of the property, or my employees with wages as their sole compensation, will do the work, and the structure is not intended or offered for sale (Sec. 7044, Business and Professional Code: The Contractors License Law does not apply to an owner of property who builds or improves thereon, and who does such work himself or herself or through his/her own employees, provided that such improvements are not intended or offered for sale. If, however, the building or improvement is sold within one year of completion, the owner-builder will have the burden of proving that he/she did not build or improve for the purpose of sale.)

I, as owner of the property, am exclusively contracting with licensed contractors to construct the project (Sec. 7044, Business and Professions Code: The Contractors License Law does not apply to an owner of property who builds or improves thereon, and who contracts for such projects with a contractor(s) licensed pursuant to the Contractors License Law).

I am exempt under Sec. B & PC for this reason:

Date 8 Owner Signature

IN ISSUING THIS BUILDING PERMIT, the applicant represents, and the city relies on the representation of the applicant, that the applicant verified all measurements and locations shown on the application or accompanying drawings and that the improvement to be constructed does not violate any law or private agreement relating to permissible or prohibited locations for such improvements. This building permit does not authorize any illegal location of any improvement or the violation of any private agreement relating to location of improvements.

I certify that I have read this application and state that all information is correct. I agree to comply with all city and county ordinances and state laws relating to building construction and herby authorize representative(s) of this city to enter upon the above mentioned property for inspection purposes.

Date 8/6/98 Applicant/Agent Signature

WORKER'S COMPENSATION DECLARATION: I hereby affirm under penalty of perjury one of the following declarations:

I have and will maintain a certificate of consent to self-insure for workers' compensation as provided for by Section 3700 of the Labor Code, for the performance of work for which the permit is issued.

X I have and will maintain workers' compensation insurance, as required by Section 3700 of the Labor Code, for the performance of the work for which this permit is issued. My workers' compensation insurance carrier and policy number are:

Carrier State Fund Policy Number 1488164-98

(This section need not be completed if the permit is for \$100 or less) I certify that in the performance of the work for which this permit is issued, I shall not employ any person in any manner so as to become subject to the workers' compensation laws of California and agree that if I should become subject to the workers' compensation provisions of Section 3700 of the Labor Code, I shall comply with those provisions.

Date 8/6/98 Applicant Signature

WARNING: FAILURE TO SECURE WORKER'S COMPENSATION COVERAGE IS UNLAWFUL AND SHALL SUBJECT AN EMPLOYER TO CRIMINAL PENALTIES AND CIVIL FINES UP TO ONE HUNDRED THOUSAND DOLLARS (\$100,000) IN ADDITION TO THE COST OF COMPENSATION, DAMAGES AS PROVIDED FOR IN SECTION 3706 OF THE LABOR CODE, INTEREST AND ATTORNEY'S FEE.

THIS PERMIT SHALL EXPIRE BY LIMITATION IF WORK IS NOT COMMENCED WITHIN 180 DAYS.

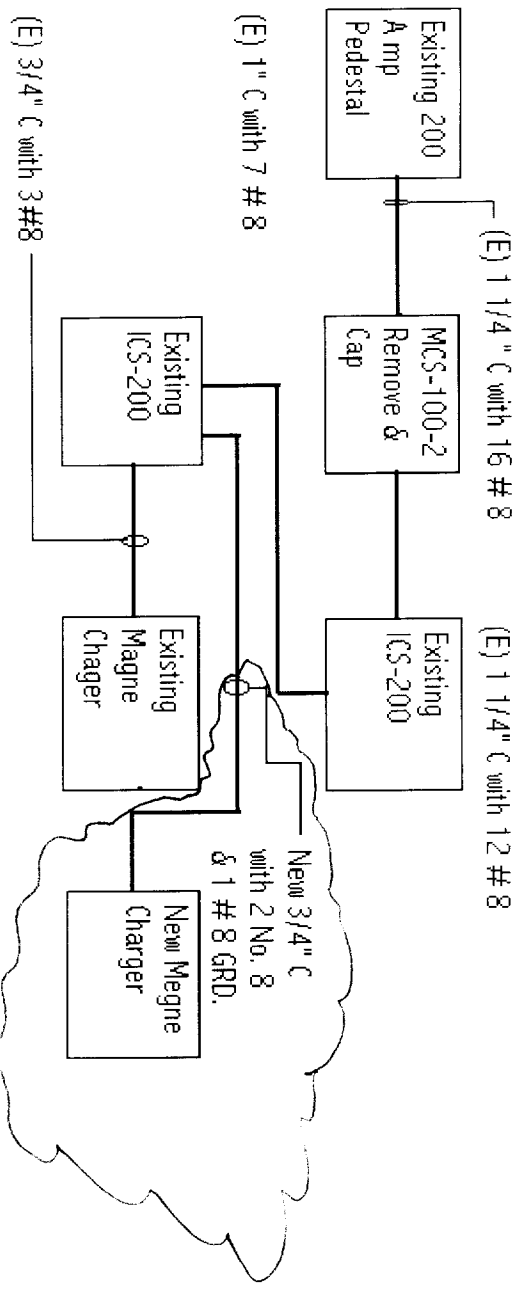

Add Two # 8 THHN back to existing pedestal through existing conduits. Ground for new Magne Charger is at existing ICS-200

ONE LINE DIAGRAM  
NO SCALE

13th & J Garage Lot E

APPROVED FOR 1993  
E-6-98 dm

19951111

NEW	X	EXISTING	PANEL				AIC: 10,000		
VOLTAGE 120/208 V			EV-1				TYPE: 200A Main Breaker		
BUS 200A KVA: 26.4			MOUNTING: Pedestal				LOCATION: 13th & J Street Garage		

c k #	KVA LOAD			LOAD DESCRIPTION	Ckt Brkr		Ckt Brkr		LOAD DESCRIPTION	KVA LOAD			c k #
	A PH	B PH	C PH		Trip	Pole	Trip	Pole		A PH	B PH	C PH	
1	3.3	---	---	EV-1 Charger	40		40		ICS-200	3.3	----	----	2
3	---	3.3	----	No. 1		2		2	No. 1	----	3.3	----	4
5	---	----	3.3	EV-1 Charger	40					----	----	----	6
7	3.3	----	----	No. 2		2				----	----	----	8
9	---	3.3	----	ICS-200	40					----	----	----	10
11	---	----	3.3	No. 2		2				----	----	----	12
13	---	----	----							----	----	----	14
15	----	----	----							----	----	----	16
17	---	---	----							----	----	----	18
19		----	----							----	----	----	20
21		---	----							----	----	----	22
23	----		----							----	----	----	24
25		---	----							----	----	----	26
27	---		----							----	----	----	28
29		----								----	----	----	30
31		---	----							----	----	----	32
33	----		----							----	----	----	34
35	----	---								----	----	----	36
37		----	----							----	----	----	38
39	---		----							----	----	----	40
41	----	----								----	----	----	42

Line Totals	9.9	9.9	6.6
Constant Load	----	----	----
KVA per PH.	9.9	9.9	6.6
Line Amps	82.5	82.5	55
Total KVA Load		26.4	

$$\frac{KVA \times 1000}{V \times 1.73} = \frac{26.4 \times 1000}{208 \times 1.73} = \frac{26,400}{359.84} = 73.4 \text{ Amps}$$

# MAGNE CHARGE

Smart Power for Electric Vehicles

## FLOOR MOUNT STANDARD INDUCTIVE CHARGER

MODEL NUMBER FM200  
PART NUMBER 16239219/16252059

### SPECIFICATIONS

Utility Power	
Input Voltage	208 - 240 VAC Single Phase
Input Current (MAX)	30 A AC RMS
Frequency	50/60 Hz
Total Harmonic Distortion	< 5% (3% in any harmonic), Full power
Power Factor	≥ 0.99@ full power
Input Power Rating	4.1 kW @ 165 VAC, 7.5kW@250 VAC
User Interface	
Vacuum Fluorescent Display	State of Charge, Charge Completion, Error messages and Time to Complete
Circuit Breaker	250 VA, 30 A
External Port	Service use.
External Ventilation Control	12 VDC, 50ma
Charger Control	
Bus Protocol	SAE J1850
Communication link between charger and vehicle.	Bi-directional RF
Transmit - Receive Frequency	915 MHz - AM Modulation
Transfer Rate	10.4 Kbits /sec
Mechanical	
Envelope (mm)	310.5 deep x 355.6 wide x 1,469.7 high
Mass (kg)	75 (unit only) 225lbs (Shipping)
Connection to Utility Power	Internal junction box
Charge Cable Retraction	Automatic mechanism
Mounting	Base plate attaches to prepared surface
Operational Environmental	
Temperature	-18 °C to +49 °C
Enclosure	Rain proof - NEMA type 3R
Durability	10 years or 18,000 hours
Acoustic	<60dB (A) between 16 Hz and 20KHz
Warranty	3 Years

GM Advanced Technology Vehicles  
3050 W. Lomita Blvd  
P O Box 2923  
Torrance, Ca. 90509-2923  
(310)517-5458 or Fax (310)517-5702  
Email morahans@pcssmtp.hac.com

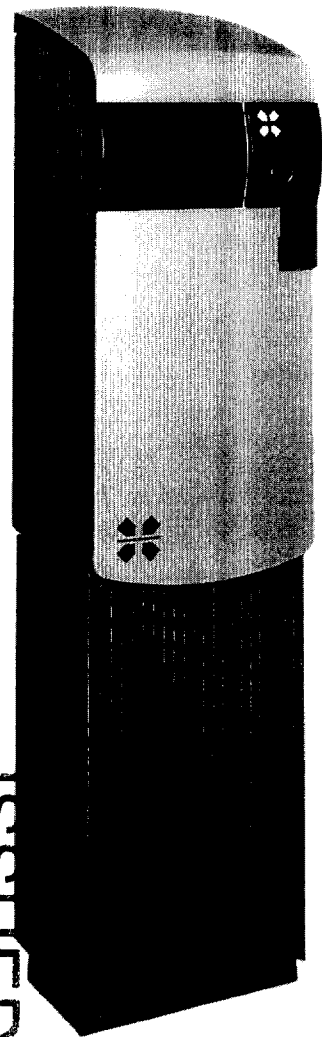

ISSUED  
AUG 18 1998



EV Battery Charger  
7M60