

CITY OF SACRAMENTO
1231 I Street, Sacramento, CA 95814

Permit No: 0612624
Insp Area: 3
Thos Bros: 318C1

Site Address: 7919 FOLSOM BL SAC
Parcel No: 079-0200-054

PAID
CITY OF SACRAMENTO
AUG 16 2006

Sub-Type: COM
Housing (Y/N): N

CONTRACTOR
INDOOR ENVIRONMENTAL SERVICES
P O BOX 418194
SACRAMENTO CA 95841

OWNER-NEIGHBORHOODS PLANNING
AND DEVELOPMENT SERVICES
CAMPBELL CENTER INV
7919 FOLSOM BL
SACRAMENTO, CA 95841

ARCHITECT

Nature of Work: INSTALL NEW DUCTLESS SPLIT HVAC SYSTEM (128LB CONDENSER @ ROOF)

CONSTRUCTION LENDING AGENCY : I hereby affirm under penalty of perjury that there is a construction lending agency for the performance of the work for which this permit is issued (Sec. 3097, Civ. C).

Lender's Name _____ Lender's Address _____

LICENSED CONTRACTORS DECLARATION: I hereby affirm under penalty of perjury that I am licensed under provisions of Chapter 9 (commencing with section 7000) of Division 3 of the Business and Professions Code and my license is in full force and effect.

License Class B License Number 646794 Date 8/16/06 Contractor Signature [Signature]

OWNER-BUILDER DECLARATION: I hereby affirm under penalty of perjury that I am exempt from the contractors License Law for the following reason (Sec. 7031.5, Business and Professions Code; any city or county which requires a permit to construct, alter, improve, demolish, or repair any structure, prior to its issuance, also requires the applicant for such permit to file a signed statement that he or she is licensed pursuant to the provisions of the Contractors License Law (Chapter 9 (commencing with Section 7000) of Division 8 of the Business and Professions Code) or that he or she is exempt therefrom and the basis for the alleged exemption. Any violation of Section 7031.5 by any applicant for a permit subjects the applicant to a civil penalty of not more than five hundred dollars (\$500.00);

I, as a owner of the property, or my employees with wages as their sole compensation, will do the work, and the structure is not intended or offered for sale (Sec. 7044, Business and Professional Code: The Contractors License Law does not apply to an owner of property who builds or improves thereon, and who does such work himself or herself or through his/her own employees, provided that such improvements are not intended or offered for sale. If, however, the building or improvement is sold within one year of completion, the owner-builder will have the burden of proving that he/she did not build or improve for the purpose of sale.)

I, as owner of the property, am exclusively contracting with licensed contractors to construct the project (Sec. 7044, Business and Professions Code: The Contractors License Law does not apply to an owner of property who builds or improves thereon, and who contracts for such projects with a contractor(s) licensed pursuant to the Contractors License Law).

I am exempt under Sec. _____ B & PC for this reason: _____

Date _____ Owner Signature _____

IN ISSUING THIS BUILDING PERMIT, the applicant represents, and the city relies on the representation of the applicant, that the applicant verified all measurements and locations shown on the application or accompanying drawings and that the improvement to be constructed does not violate any law or private agreement relating to permissible or prohibited locations for such improvements. This building permit does not authorize any illegal location of any improvement or the violation of any private agreement relating to location of improvements.

I certify that I have read this application and state that all information is correct. I agree to comply with all city and county ordinances and state laws relating to building construction and hereby authorize representative(s) of this city to enter upon the abovementioned property for inspection purposes.

Date 8/16/06 Applicant/Agent Signature [Signature]

WORKER'S COMPENSATION DECLARATION: I hereby affirm under penalty of perjury one of the following declarations:
I have and will maintain a certificate of consent to self-insure for workers' compensation as provided for by Section 3700 of the Labor Code, for the performance of work for which the permit is issued.

I have and will maintain workers' compensation insurance, as required by Section 3700 of the Labor Code, for the performance of the work for which this permit is issued. My workers' compensation insurance carrier and policy number are:

Carrier AN GUARANTEE & LIABILITY INS C Policy Number WSA184333100 Exp Date 07/01/2007

(This section need not be completed if the permit is for \$100 or less) I certify that in the performance of the work for which this permit is issued, I shall not employ any person in any manner so as to become subject to the workers' compensation laws of California and agree that if I should become subject to the workers' compensation provisions of Section 3700 of the Labor Code, I shall forthwith comply with those provisions.

Date 8/16/06 Applicant Signature [Signature]

WARNING: FAILURE TO SECURE WORKER'S COMPENSATION COVERAGE IS UNLAWFUL AND SHALL SUBJECT AN EMPLOYER TO CRIMINAL PENALTIES AND CIVIL FINES UP TO ONE HUNDRED THOUSAND DOLLARS (\$100,000) IN ADDITION TO THE COST OF COMPENSATION, DAMAGES AS PROVIDED FOR IN SECTION 3706 OF THE LABOR CODE, INTEREST AND ATTORNEY'S FEE.

THIS PERMIT SHALL EXPIRE BY LIMITATION IF WORK IS NOT COMMENCED WITHIN 180 DAYS.

APPLICATION FOR COMMERCIAL BUILDING PERMIT

**CITY OF SACRAMENTO
PLANNING & BUILDING DIVISION
PERMIT SERVICES SECTION
(916) 808-2534 FAX: (916) 808-7046**

ACTIVITY # <u>06/2624</u>	Insp. Area <u>3</u>
------------------------------	------------------------

Applicant **MUST** complete ALL Unshaded Areas

ADDRESS: 7919 Folsom Blvd Suite: _____

PARCEL #: _____

<p style="text-align: center;">CONTACT</p> <p>Name: <u>MIKE RUBINO</u> Street Address: <u>1512 SILICA AVE</u> City/State/Zip: <u>SACRAMENTO CA 95815</u> Phone: <u>(916) 988-8808</u> E-Mail: <u>MRUBINO@IES-HVAC.COM</u></p>	<p style="text-align: center;">LICENSED CONTRACTOR Lic No. # <u>646794</u></p> <p>Name: <u>INDOOR ENVIR. SERVICES</u> Street Address: <u>1512 SILICA AVE</u> City/State/Zip: <u>SACRAMENTO CA 95815</u> Phone: <u>(916) 988-8808</u> E-Mail: _____</p>
<p style="text-align: center;">ARCHITECT/ENGINEER</p> <p>Name: <u>NA</u> Street Address: _____ City/State/Zip: _____ Phone: _____ E-Mail: _____</p>	<p style="text-align: center;">OWNER</p> <p>Name: <u>CA ST. TEACHERS RETIREMENT</u> Street Address: <u>7919 Folsom Blvd.</u> City/State/Zip: <u>SAC CA 95814</u> Phone: <u>(916) 229-3939</u> E-Mail: _____</p>

⇒ Will permittee have any employees on the jobsite? No Yes ⇒ Insurance Co.: UNITED STATES FIDELITY

⇒ WORKER'S COMPANSATION POLICY # D278W00004 EXPROATION DATE: 12/01/06

NATURE OF WORK IN DETAIL: INSTALL ONE MITSUBISHI DUCTLESS SPLIT PROPETAR CONDENSER AND COMPUTER ROOM AIR HANDLER

OCCUPANT/TENANT: OFFICE VALUATION: \$7,235.00

FLOOD STATUS:			B.C.A.T.							
JOB DESCRIPTION	BLDG	WELL	APT	TI	RM	SW	FIRE	ADD	OTH	
INSPECTION DISCIPLINES	BLDG	MECH	PLUMB	ELEC		SPE	FIRE			
				Fire Reg. Y/N	SPR		ALARM	FD	FW	UTIL
# Stories	1" W/ Alarm	Well Type	Well Depth	Occp Group	Const type					
B	L	F	N	E	E	S		D	FW UTIL	

COMMENTS: _____

REGIONAL SANITATION DISTRICT Yes No HEALTH DEPARTMENT: Yes No

WATER FLOW TEST FOR NEW BUILDINGS OR ADDITIONS? Provided Faxed

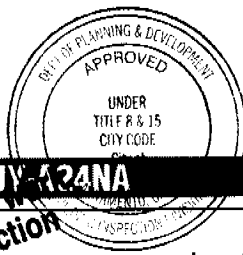

This set of plans and specifications must be kept on the job at all times and it is unlawful to make any changes or alterations from the same without written permission from the Building Inspection Division. **Mitsubishi SLIM** Split-ductless A/C and Heat Pumps

SUBMITTAL DATA: MSY-A24NA & MUY-A24NA 24,000 Btu/h WALL-MOUNTED AIR-CONDITIONING SYSTEM

Job Name: _____ Location: _____ Date: _____
Purchaser: _____ Engineer: _____
Submitted to: _____ For Reference Approval Construction
Unit Designation: _____ Schedule No.: _____

GENERAL FEATURES

- Limited warranty: one year on parts and defects and six years on compressor
- Compact side discharge outdoor unit
- Zone control
- Wireless remote controller
- Automatic fan speed control
- Quiet operation – both indoor and outdoor units
- Auto restart following a power outage
- Self check function – onboard diagnostics
- Advanced microprocessor control

Rated capacity 22,000 Btu/h
Minimum capacity 4,400 Btu/h
SEER 16.0 Btu/h/W
Total input 2880 W
Power supply 208 / 230V, 1 Phase, 60 Hz
Breaker size 20 A

Voltage
Indoor - Outdoor S1-S2
Indoor - Outdoor S2-S3
Indoor - Remote Controller

Indoor unit
MCA 1.0 A
Fan motor 0.76 F.L.A.
Fan motor output
Airflow (Lo-Med-Hi) 296-431-568 Dry CFM
265-385-508 Wet CFM
Sound (level) (Lo-Med-Hi) 34-40-49 dB(A)

DIMENSIONS		INCHES	MM
inches	W	43-5/16	1100
	D	10-1/4	260
	H	12-13/16	325

Weight (lbs/Kg) 37 / 17
Field drain pipe size I.D. (inches/mm) 1/2 / 12.7

PROVIDE DISCONNECTS FOR BOTH UNITS

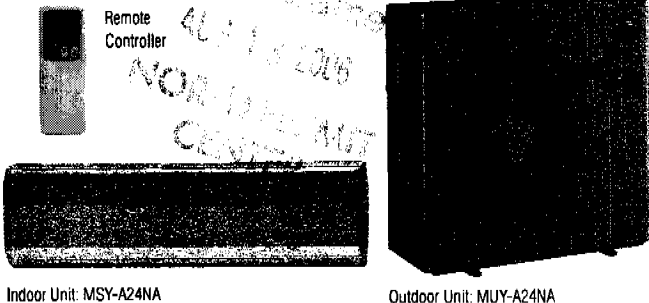

Outdoor Unit
Compressor DC inverter/twin rotary
MCA 17
Fan motor 0.93 F.L.A.
Sound level 55 dB(A)

DIMENSIONS	INCHES	MM
W	33-1/16	840
D	13	330
H	33-7/16	849

Weight (lbs/Kg) 128 / 58
Refrigerant type R410A
Refrigerant pipe size O.D. (inches/mm)
gas side 5/8 / 15.88
liquid side 1/4 / 6.35
Max. refrigerant pipe length (ft/m) 100 / 30
Max. refrigerant pipe height difference (ft/m) 50 / 15
Connection method flared

NOTES :

*1. Rating conditions (cooling)-indoor : D.B. 80°F, W.B. 67°F
outdoor : D.B. 95°F, W.B. 75°F.

Operating range

Cooling	Indoor intake air temp.		Outdoor intake air temp.
	Maximum	D.B. 95°F, W.B. 71°F	D.B. 115°F
Minimum	D.B. 67°F, W.B. 57°F	D.B. 0°F *	

* With wind baffle installed. If not installed, the minimum temperature will be 23°FDB.



APPROVED PER 2002

NATIONAL ELECTRICAL CODE AND CITY OF SACRAMENTO AMENDMENTS

8-16-06 *[Signature]*

ELECTRICAL DIVISION

Notes:

THIS APPROVAL IS SUBJECT TO THE CITY OF SACRAMENTO BUILDING INSPECTION DIVISION

DIMENSIONS: MSY-A24NA & MUY-A24NA

MSY-A24NA

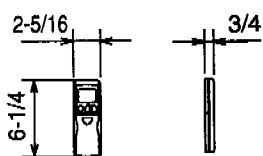
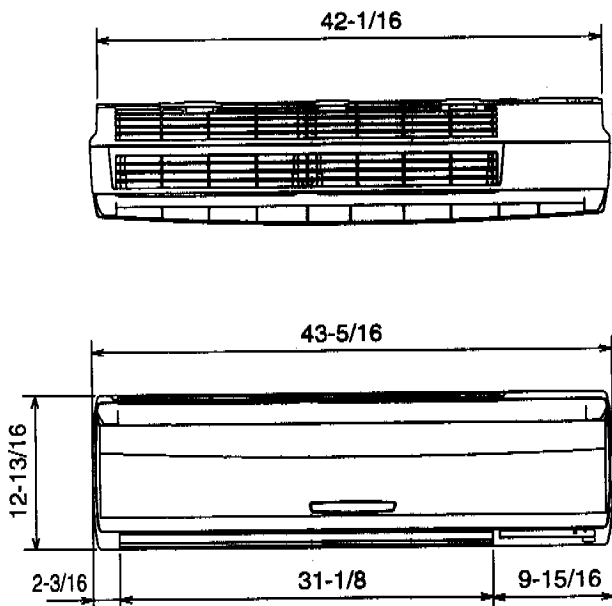

Wireless remote controller

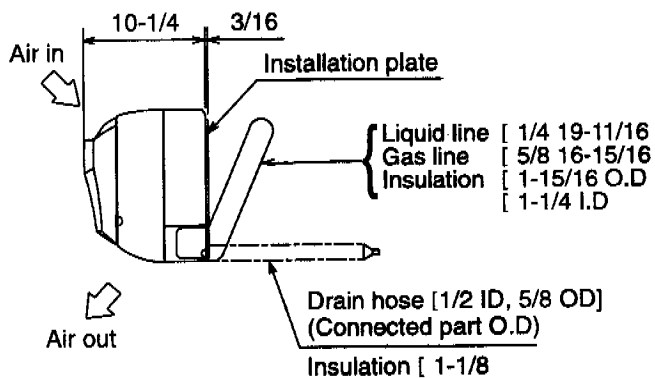

MUY-A24NA

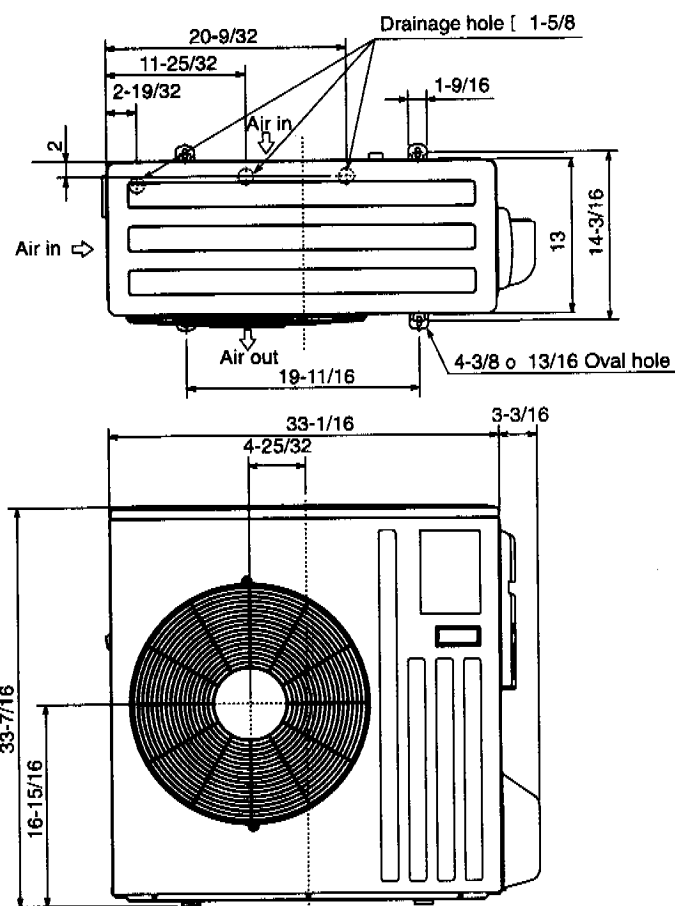

HVAC Advanced Products Division
Mitsubishi Electric & Electronics USA, Inc.

3400 Lawrenceville Suwanee Rd
Suwanee, GA 30024
Tele: 678-376-2900 • Fax: 800-889-9904
Toll Free: 800-433-4822 (#3)
www.mehvac.com

65TH AVE

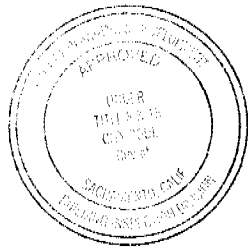

This set of plans and specifications must be kept on the job at all times and it is unlawful to make any changes or alterations from the same without written permission from the Building Inspection Division.
The approval of this plan and specification SHALL NOT be held to permit or approve the violation of any City Ordinance or State Law.

Folsom Blvd

Highway 99



7919 Folsom Blvd

Howe

City of Los Angeles
Building Inspection Division

NORTH
↓