

CITY OF SACRAMENTO

1231 I Street, Sacramento, CA 95814

Permit No: 0014921

Insp Area: 4

Site Address: 1101 GLENROSE AV SAC

Parcel No: 265-0261-071

Sub-Type: RES

Housing (Y/N): N

CONTRACTOR

TOM YANCEY HOME TEAM
7101 FAIR OAKS BLVD
CARMICHAEL CA 95608

OWNER

MC CLEARY ELMER A
1101 GLENROSE AV
SACRAMENTO CA 95815

ARCHITECT

Nature of Work: 10 SQ SIDING, S & S/E SIDES OF BLDG

CONSTRUCTION LENDING AGENCY: I hereby affirm under penalty of perjury that there is a construction lending agency for the performance of the work for which this permit is issued (Sec. 3097, Civ. C.)

Lender's Name _____ Lender's Address _____

LICENSED CONTRACTORS DECLARATION: I hereby affirm under penalty of perjury that I am licensed under provisions of Chapter 9 (commencing with section 7000) of Division 3 of the Business and Professions Code and my license is in full force and effect.

X License Class C License Number _____ Date 12/19/00 Contractor Signature Janet Whitfield

OWNER-BUILDER DECLARATION: I hereby affirm under penalty of perjury that I am exempt from the contractors License Law for the following reason (Sec. 7031.5, Business and Professions Code; any city or county which requires a permit to construct, alter, improve, demolish, or repair any structure, prior to its issuance, also requires the applicant for such permit to file a signed statement that he or she is licensed pursuant to the provisions of the Contractors License Law (Chapter 9 (commencing with Section 7000) of Division 8 of the Business and Professions Code) or that he or she is exempt therefrom and the basis for the alleged exemption. Any violation of Section 7031.5 by any applicant for a permit subjects the applicant to a civil penalty of not more than five hundred dollars (\$500.00).

I, as a owner of the property, or my employees with wages as their sole compensation, will do the work, and the structure is not intended or offered for sale (Sec. 7044, Business and Professional Code). The Contractors License Law does not apply to an owner of property who builds or improves thereon, and who does such work himself or herself or through his/her own employees, provided that such improvements are not intended or offered for sale. If, however, the building or improvement is sold within one year of completion, the owner-builder will have the burden of proving that he/she did not build or improve for the purpose of sale.)

I, as owner of the property, am exclusively contracting with licensed contractors to construct the project (Sec. 7044, Business and Professions Code). The Contractors License Law does not apply to an owner of property who builds or improves the project who contracts for such projects with a contractor(s) licensed pursuant to the Contractors License Law.

**PAID
CITY OF SACRAMENTO**

I am exempt under Sec. _____ B & PC for this reason: _____

Date _____ Owner Signature _____

DEC 19 2000

IN ISSUING THIS BUILDING PERMIT, the applicant represents, and the city relies on the representation of the applicant, that the applicant verified all measurements and locations shown on the application or accompanying drawings and that the improvement to be constructed does not violate any law or private agreement relating to permissible or prohibited locations for such improvements. This building permit does not authorize any illegal location of any improvement or the violation of any private agreement relating to location of improvements.

**NEIGHBORHOODS PLANNING
AND DEVELOPMENT SERVICES**

I certify that I have read this application and state that all information is correct. I agree to comply with all city and county ordinances and state laws relating to building construction and hereby authorize representative(s) of this city to enter upon the abovementioned property for inspection purposes.

X Date 12 19 00 Applicant/Agent Signature Janet Whitfield

WORKER'S COMPENSATION DECLARATION: I hereby affirm under penalty of perjury one of the following declarations:

I have and will maintain a certificate of consent to self-insure for workers' compensation as provided for by Section 3700 of the Labor Code, for the performance of work for which the permit is issued.

X I have and will maintain workers' compensation insurance, as required by Section 3700 of the Labor Code, for the performance of the work for which this permit is issued. My workers' compensation insurance carrier and policy number are:

Carrier STATE FUND Policy Number 1449368-00 Exp Date 01/01/2001

(This section need not be completed if the permit is for \$100 or less) I certify that in the performance of the work for which this permit is issued, I shall not employ any person in any manner so as to become subject to the workers' compensation laws of California and agree that if I should become subject to the workers' compensation provisions of Section 3700 of the Labor Code, I shall forthwith comply with those provisions.

X Date 12 19 00 Applicant Signature Janet Whitfield

WARNING: FAILURE TO SECURE WORKER'S COMPENSATION COVERAGE IS UNLAWFUL AND SHALL SUBJECT AN EMPLOYER TO CRIMINAL PENALTIES AND CIVIL FINES UP TO ONE HUNDRED THOUSAND DOLLARS (\$100,000) IN ADDITION TO THE COST OF COMPENSATION, DAMAGES AS PROVIDED FOR IN SECTION 3706 OF THE LABOR CODE, INTEREST AND ATTORNEY'S FEE.

THIS PERMIT SHALL EXPIRE BY LIMITATION IF WORK IS NOT COMMENCED WITHIN 180 DAYS.

WOOD TRIM DETAILS WITH VINYL SIDING

NOTE: THESE DRAWINGS ARE ILLUSTRATIVE ONLY AND NOT INTENDED AS CONSTRUCTION DOCUMENTS.

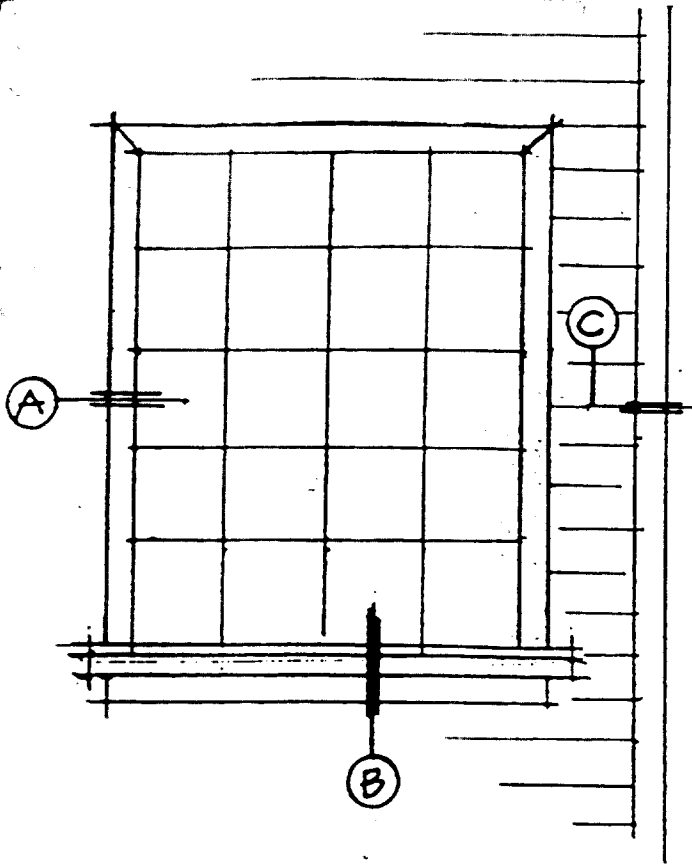

WINDOW ELEVATION

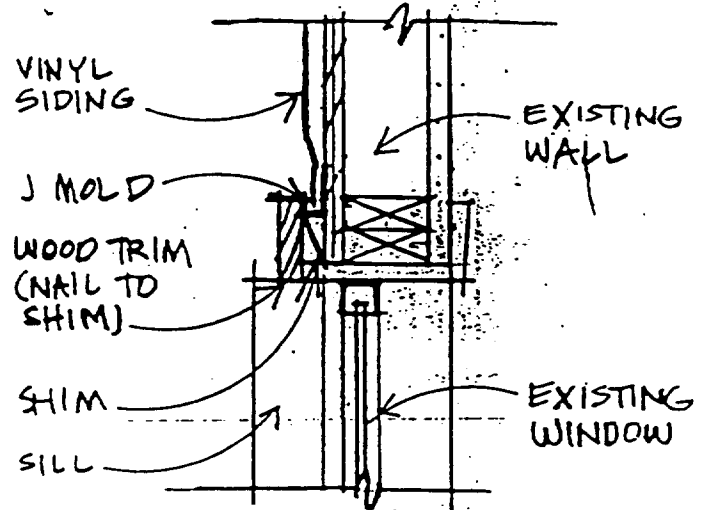

A JAMB

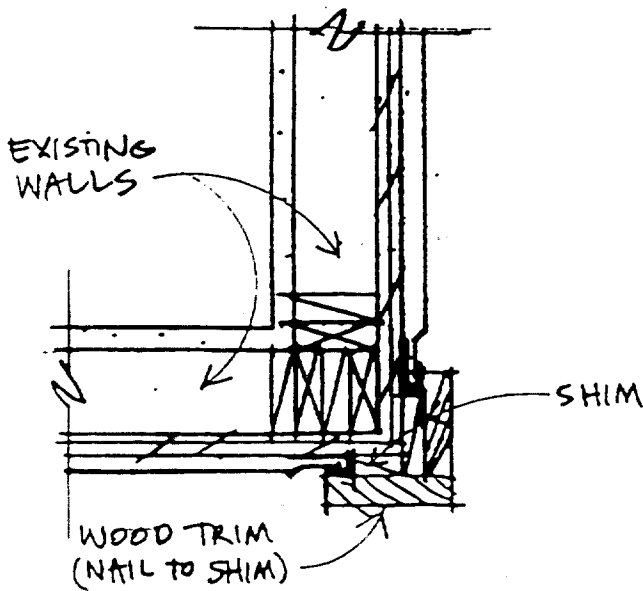

C CORNER

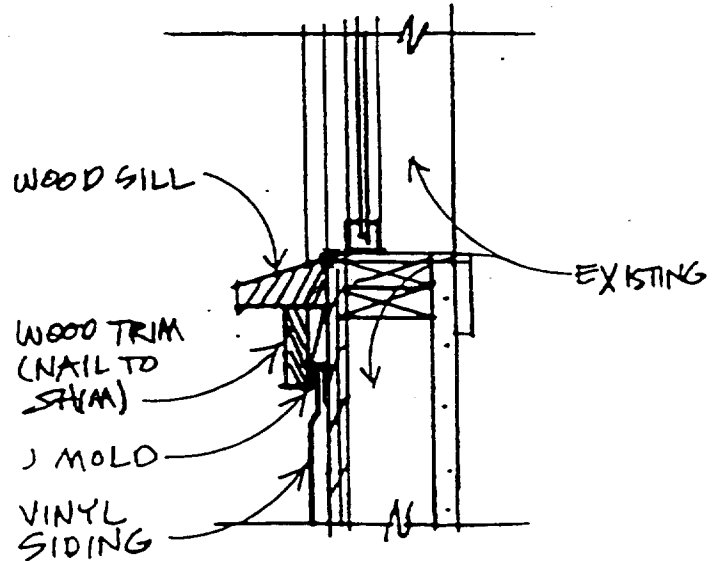

B SILL

NOTE: ALL WATERPROOFING IS THE CONTRACTOR'S RESPONSIBILITY.

TOM YANCEY COMPANY

1001 E. Highway 101, Suite 100, Ukiah, CA 95608
Phone: (707) 462-1890 Fax: (707) 462-1893
www.tomyancey.com

No. 11-12-96

CONTRACT / CHANGE ORDER

11-12-96

WORK ORDER # 1006 / CHANGE ORDER
11-12-96

"Tom Yancey" an Industry Name Since 1888™

LIST DESCRIPTION OF WORK

CHANGE ORDER TO CONTRACT # 20549

ADD SIDING AS PER CONTRACT TO (2) WALLS
ON SOUTH SIDE OF BUILDING
1. 1/2" INSULATION
2. 3 SIDED (PARTIAL) NEW VINYL WAVE SIDING
3. VAPOR BARRIER BOARD - WHITE
4. 1/2" VAPOR/INSULATION BOARD TO WALL SURFACES
5. 1/2" ALUM. M-BOARD SIDING OVER INSULATION BOARD
6. SET ALL WINDOWS & DOOR OPENINGS WITH 1x3 VINYL
TRIM
7. CLEAN JOBSITE. CLEAN UP DEBRIS

DEPOSIT \$ 500.00
CK# 1652

* NOTE: WINDOW TRIM
EVENST. ON PEBBLESTONE

TOM YANCEY 5 YR. GUARANTEE
WARRANTY

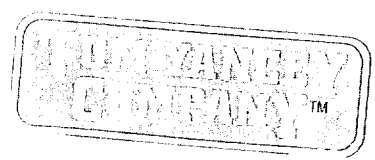

INCLUDES ALL OFFERS & DISCOUNTS

Alvin Mc Cleary
1127 Glenrose Ave
Berkeley CA 94815

45

17

124