

**CITY OF SACRAMENTO**  
1231 I Street, Sacramento, CA 95814

**Permit No:** 0317497  
**Insp Area:** 4  
**Thos Bros:** 257-B4

**Site Address:** 261 ROCK HOUSE CR NORTH SAC  
**Parcel No:** 201-0640-046  
N

**Sub-Type:** NSFR  
**HERITAGE @ NATOMAS PARK 17 LOT 46** Housing (Y/N):

CONTRACTOR  
LENNAR RENAISSANCE INC  
2240 DOUGLAS BL  
ROSEVILLE, CA 95661

OWNER

ARCHITECT

**Nature of Work:** MP1151 5 RMS 1 STORY SFR

**CONSTRUCTION LENDING AGENCY:** I hereby affirm under penalty of perjury that there is a construction lending agency for the performance of the work for which this permit is issued (Sec. 3097, Civ. C).

Lender's Name \_\_\_\_\_ Lender's Address \_\_\_\_\_

**LICENSED CONTRACTORS DECLARATION:** I hereby affirm under penalty of perjury that I am licensed under provisions of Chapter 9 (commencing with section 7000) of Division 3 of the Business and Professions Code and my license is in full force and effect.

License Class \_\_\_\_\_ License Number 732348 Date 12/3/03 Contractor Signature Kim Mason

**OWNER-BUILDER DECLARATION:** I hereby affirm under penalty of perjury that I am exempt from the contractors License Law for the following reason (Sec. 7031.5, Business and Professions Code; any city or county which requires a permit to construct, alter, improve, demolish, or repair any structure, prior to its issuance, also requires the applicant for such permit to file a signed statement that he or she is licensed pursuant to the provisions of the Contractors License Law (Chapter 9 (commencing with Section 7000) of Division 8 of the Business and Professions Code) or that he or she is exempt therefrom and the basis for the alleged exemption. Any violation of Section 7031.5 by any applicant for a permit subjects the applicant to a civil penalty of not more than five hundred dollars (\$500.00);

\_\_\_\_ I, as a owner of the property, or my employees with wages as their sole compensation, will do the work, and the structure is not intended or offered for sale (Sec. 7044, Business and Professional Code: The Contractors License Law does not apply to an owner of property who builds or improves thereon, and who does such work himself or herself or through his/her own employees, provided that such improvements are not intended or offered for sale. If, however, the building or improvement is sold within one year of completion, the owner-builder will have the burden of proving that he/she did not build or improve for the purpose of sale.)

\_\_\_\_ I, as owner of the property, am exclusively contracting with licensed contractors to construct the project (Sec. 7044, Business and Professions Code: The Contractors License Law does not apply to an owner of property who builds or improves thereon, and who contracts for such projects with a contractor(s) licensed pursuant to the Contractors License Law).

\_\_\_\_ I am exempt under Sec. \_\_\_\_\_ B & PC for this reason: \_\_\_\_\_

Date \_\_\_\_\_ Owner Signature \_\_\_\_\_

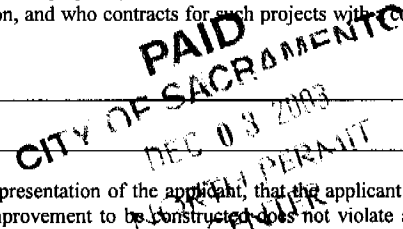

**IN ISSUING THIS BUILDING PERMIT,** the applicant represents, and the city relies on the representation of the applicant, that the applicant verified all measurements and locations shown on the application or accompanying drawings and that the improvement to be constructed does not violate any law or private agreement relating to permissible or prohibited locations for such improvements. This building permit does not authorize any illegal location of any improvement or the violation of any private agreement relating to location of improvements.

I certify that I have read this application and state that all information is correct. I agree to comply with all city and county ordinances and state laws relating to building construction and hereby authorize representative(s) of this city to enter upon the abovementioned property for inspection purposes.

Date 12/3/03 Applicant/Agent Signature Kim Mason

**WORKER'S COMPENSATION DECLARATION:** I hereby affirm under penalty of perjury one of the following declarations:

\_\_\_\_ I have and will maintain a certificate of consent to self-insure for workers' compensation as provided for by Section 3700 of the Labor Code, for the performance of work for which the permit is issued.

\_\_\_\_ I have and will maintain workers' compensation insurance, as required by Section 3700 of the Labor Code, for the performance of the work for which this permit is issued. My workers' compensation insurance carrier and policy number are:

Carrier OLD REPUBLIC INS. CO. Policy Number MWC10845400 Exp Date 11/01/2003

\_\_\_\_ (This section need not be completed if the permit is for \$100 or less) I certify that in the performance of the work for which this permit is issued, I shall not employ any person in any manner so as to become subject to the workers' compensation laws of California and agree that if I should become subject to the workers' compensation provisions of Section 3700 of the Labor Code, I shall forthwith comply with those provisions.

Date 12/3/03 Applicant Signature Kim Mason

**WARNING: FAILURE TO SECURE WORKER'S COMPENSATION COVERAGE IS UNLAWFUL AND SHALL SUBJECT AN EMPLOYER TO CRIMINAL PENALTIES AND CIVIL FINES UP TO ONE HUNDRED THOUSAND DOLLARS (\$100,000) IN ADDITION TO THE COST OF COMPENSATION, DAMAGES AS PROVIDED FOR IN SECTION 3706 OF THE LABOR CODE, INTEREST AND ATTORNEY'S FEE.**

**THIS PERMIT SHALL EXPIRE BY LIMITATION IF WORK IS NOT COMMENCED WITHIN 180 DAYS.**

RESIDENTIAL SUBDIVISION BUILDING PERMIT APPLICATION

Project Address: 201 Rock House Cir Assessor Parcel # 201-0640-0-10-00  
Lot Number: 41c Subdivision HERITAGE PARK - Village 17

OWNER INFORMATION:

Legal Property Owner: LENNAR RENAISSANCE INC. Phone# 916-773-4083  
Owner Address: 2240 DOUGLAS BLVD, SUITE City ROSEVILLE State CA Zip 95661

CONTRACTOR INFORMATION:

Contractor: LENNAR RENAISSANCE INC. Lic. # 732348 Phone # 916-773-4083 Fax 773-4086

PROJECT INFORMATION:

Land Use Zone R/A Occupancy Group R3 Construction Type VN Fed Code 1A  
No. of Stories: 1 No. of Rooms: 5 Street Width: 40 ft  
1<sup>st</sup> Floor Area 1722 2<sup>nd</sup> Floor Area N/A Basement N/A Roof Material TILE  
AREA IN SQUARE FOOT OF:  
Dwelling/Living 1722  
Garage/Storage 440  
Decks/Balconies \_\_\_\_\_  
Carports \_\_\_\_\_  
SCOPE OF WORK: MP # 1751  
NEW CONSTRUCTION SFD

FOR OFFICE USE ONLY

- Information Above Complete  AR Flood Waiver Required  Planning Approval
- Violation Files Checked  Flood Elevation Certificate Required  Design Review Approval
- Standard Setbacks  Water Development Infill Area  Special Fee Districts Apply:
- County Sewer

THE FOLLOWING MUST BE PROVIDED IN ORDER TO SUBMIT FOR PERMIT

- 2 COMPLETE PLOT PLANS, LEGIBLE & DRAWN TO SCALE
- 11 X 17 COPY OF FLOOR PLAN WITH FOLLOWING INFORMATION
  - a) Assessor's Parcel Number
  - b) New Floor Area
  - c) Owners Name
  - d) Project Address

Date: \_\_\_\_\_ Received by: \_\_\_\_\_

47  
P=12.3

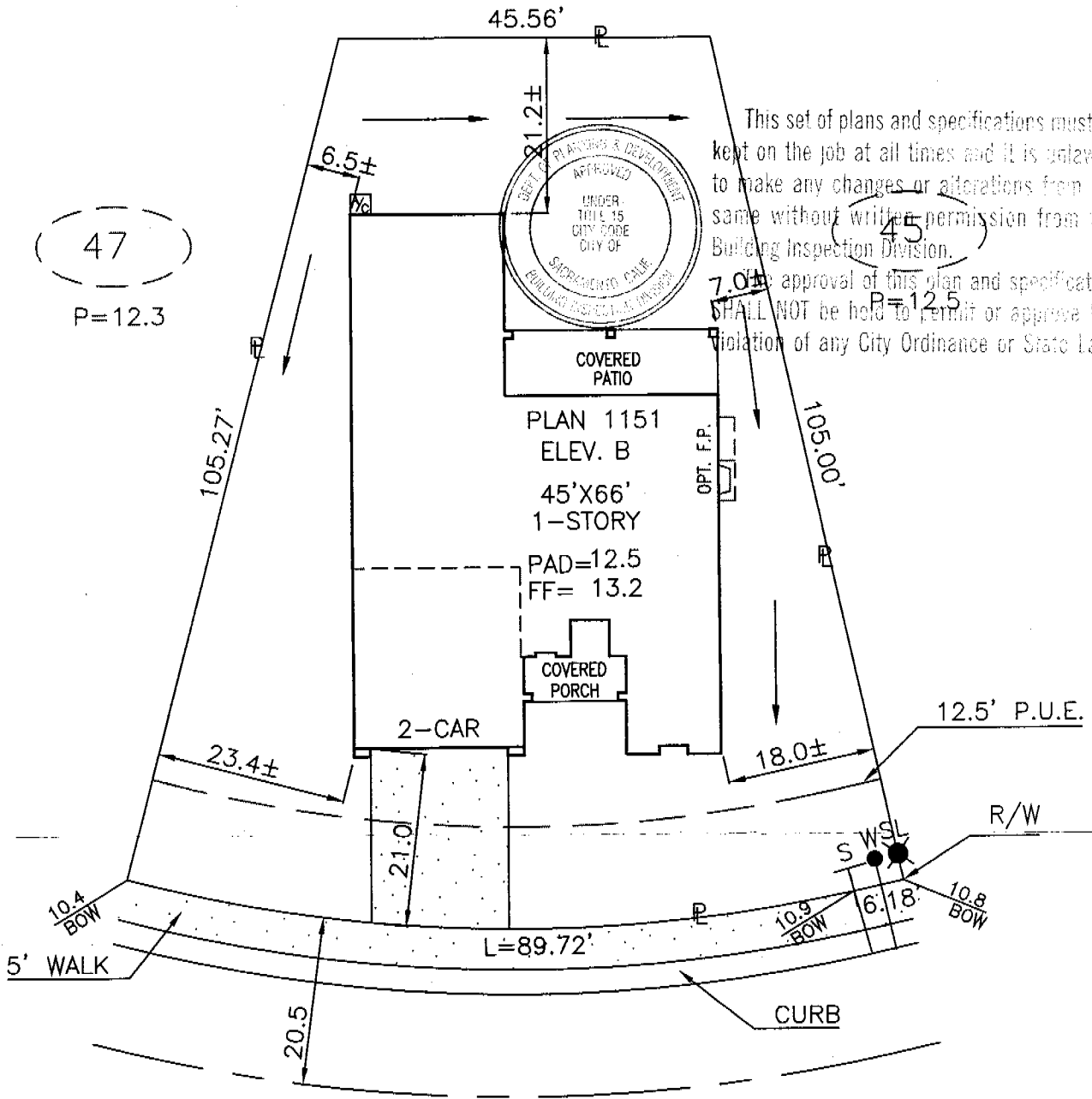

This set of plans and specifications must be kept on the job at all times and it is unlawful to make any changes or alterations from the same without written permission from the Building Inspection Division.

7.01 approval of this plan and specification SHALL NOT be held to permit or approve the violation of any City Ordinance or State Law.

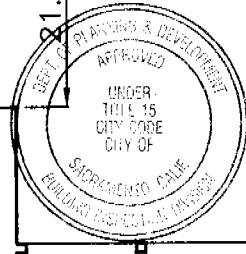

ROCK HOUSE CIRCLE NORTH

DIMENSIONS SHOWN ARE APPROXIMATE EXCEPT FOR MINIMUMS REQUIRED BY ORDINANCE. THIS PLOT DOES NOT REFLECT AS BUILT CONDITIONS AND MAY VARY FROM THIS PLAN.

<h1>RENAISSANCE HOMES</h1> <p>1075 CREEKSIDE RIDGE DR. SUITE 100. ROSEVILLE, CA. 95678 PHONE (916) 773-4083 FAX (916) 773-4086</p>	<p>NAPA VALLEY</p>		<p>PLOT PLAN</p>
	<p>HERITAGE PARK VILLAGE 17</p>		
<p>ADDRESS: 261 ROCK HOUSE CIRCLE NO.</p>			<p>NOTES:</p>
<p>PLAN NO.: 1151-B</p>	<p>LOT SQ. FT.: 7,561.7</p>	<p>LOT COV: 31.4 %</p>	
<p>DRAWN BY: R.P.</p>	<p>APPROVED BY: <i>mb</i></p>	<p>ROOF PITCH: A &amp; B ELEVS. = 4/12 PITCH C ELEV. = 7/12 PITCH</p>	<p>LOT 46</p>
<p>DATE: 10/27/03</p>		<p>SCALE: 1"=20'</p>	



**INSULATION CONTRACTORS  
ASSOCIATION  
OF AMERICA**

INSULATION  
CERTIFICATE  
**40853**

1321 DUKE STREET, SUITE 303 • ALEXANDRIA, VA 22314 • (703) 739-0356

THIS IS TO CERTIFY THAT INSULATION HAS BEEN INSTALLED IN CONFORMANCE WITH CURRENT ENERGY REGULATIONS, CALIFORNIA ADMINISTRATIVE CODE TITLE 24, STATE OF CALIFORNIA, IN THE BUILDING LOCATED AT

Leansville LOT # 46 TRACT # NAAPA

STREET 261 Rock House CITY SAC

**EXTERIOR WALLS:**

MANUFACTURER FC THICKNESS/TYPE 3/8 R-VALUE 13

**CEILING:**

MANUFACTURER FC THICKNESS/TYPE 12 R-VALUE 38

BLOWN IN: OT MINIMUM THICKNESS 1 1/4 R-VALUE 38

MANUFACTURER \_\_\_\_\_ THICKNESS/TYPE \_\_\_\_\_ R-VALUE \_\_\_\_\_

SQUARE FOOTAGE COVERED 1208 NUMBER OF BAGS USED 28

FLOORS: MANUFACTURER \_\_\_\_\_ THICKNESS/TYPE \_\_\_\_\_ R-VALUE \_\_\_\_\_

SLAB ON GRADE: MANUFACTURER \_\_\_\_\_ THICKNESS/TYPE \_\_\_\_\_ R-VALUE \_\_\_\_\_

MANUFACTURER \_\_\_\_\_ THICKNESS/TYPE \_\_\_\_\_ R-VALUE \_\_\_\_\_

WIDTH OF INSULATION \_\_\_\_\_ INCHES

FOUNDATION WALLS: MANUFACTURER \_\_\_\_\_ THICKNESS/TYPE \_\_\_\_\_ R-VALUE \_\_\_\_\_

GENERAL CONTRACTOR \_\_\_\_\_ DATE \_\_\_\_\_

CALIFORNIA CONTRACTORS LICENSE # \_\_\_\_\_

INSULATION CONTRACTOR **ARCADE INSULATION** \_\_\_\_\_ TITLE \_\_\_\_\_

CALIFORNIA CONTRACTORS LICENSE #815286 \_\_\_\_\_ DATE 4-27-11

NEVADA CONTRACTORS LICENSE #55201 \_\_\_\_\_ SIGNATURE [Signature] TITLE Rickman

**INSTALLATION CERTIFICATE**

CF-6R

261 Rock House RENAISSANCE-NAPA @ HERITAGE PARK 0.317497  
 Site Address Permit Number

An installation certificate is required to be posted at the building site or made available for all appropriate inspections. (The information provided on this form is required; however, use of this form to provide the information is optional.) After completion of final inspection a copy must be provided to the building department (upon request) and the building owner at occupancy, per Section 10-103(b).

**HVAC SYSTEMS:**  
**Heating Equipment**

Equip. Type (pkg. Heat pump)	CEC Certified Mfr name and Model #	# of Identical Systems	(1) Efficiency (ΔFUE, etc.) > CF-1R value	Duct Location (attic, etc.)	Duct or Piping R-value	Heating Load (Btu/hr)	Heating Capacity (Btu/hr)	
Furnace	CARRIER #58MVP040-14	1	94.00	Attic	R-6	32,932	40,000	Plan 1151
Furnace	CARRIER #58MVP040-14	1	94.00	Attic	R-6	34,064	40,000	Plan 1152
Furnace	CARRIER #58MVP080-20	1	94.00	Attic	R-6	35,849	80,000	Plan 1153
Furnace	CARRIER #58MVP080-20	1	94.00	Attic	R-6	35,284	80,000	Plan 1154

**Cooling Equipment**

Equip. Type (pkg. Heat pump)	CEC Certified Compressor Unit Mfr Name and Model #	# of Identical Systems	(1) Efficiency (SEER, etc.) > CF-1R Value	Duct Location (attic, etc.)	Duct R-value	Cooling Load (Btu/hr)	Cooling Capacity (Btu/hr)	
Condenser	CARRIER #38TDB038*	1	15.5	Attic	R-6	27,493	36,000	Plan 1151
Condenser	CARRIER #38TDB038*	1	15.5	Attic	R-6	30,672	36,000	Plan 1152
Condenser	CARRIER #38TDB048*	1	15.5	Attic	R-6	31,408	47,500	Plan 1153
Condenser	CARRIER #38TDB048*	1	15.5	Attic	R-6	30,905	47,500	Plan 1154

(1) ≥ reads greater than or equal to. \* = Thermal Expansion Valve  
 I, the undersigned, verify that equipment listed above is: 1) the actual equipment installed, 2) equivalent to or more efficient than that specified in the certificate of compliance (Form CF-1R) submitted for compliance with the Energy Efficiency Standards for residential buildings, and 3) equipment that meets or exceeds the appropriate requirements for manufactured devices (from the Appliance Efficiency Regulations or Part 6), where applicable.

*M. J. Tomp*  
 Signature, Date

Beutler Corporation  
 Installing Subcontractor (Co. Name)  
 OR General Contractor (Co. Name) OR Owner

**WATER HEATING SYSTEMS:**

Heater Type	CEC Certified Mfr Name & Model #	Distribution Type (Std. point of use)	If Recirculation Control Type	# of Identical Systems	(2) Rated Input (kW or Btu/hr)	Tank Volume (gallons)	(2) Efficiency (EF, RE)	(2) Standby Loss (%)	External Insulation R-value
GAS	BROADFORD WHITE FOX #45056FBN2	POX	Ø	1	40,000	50	0.02	N/A	N/A

(2) For small gas storage (rated input of less than or equal to 75,000 Btu/hr), electric resistance and heat pump water heaters, list Energy Factor. For large gas storage water heaters (rated input of greater than 75,000 Btu/hr), list Recovery Efficiency, Standby Loss and Rated Input. For instantaneous gas water heaters, list Recovery efficiency and Rated Input.  
 (3) R-12 external insulation is mandatory for storage water heaters with an energy factor of less than 0.58.

**Facets & Shower Heads:**

All facets and showerheads installed are certified to the Commission, pursuant to Title 24, Part 6, Section 111.

I, the undersigned, verify that equipment listed above my signature is: 1) the actual equipment installed, 2) equivalent to or more efficient than that specified in the certificate of compliance (Form CF-1R) submitted for compliance with the Energy Efficiency Standards for residential buildings, and 3) equipment that meets or exceeds the appropriate requirements for manufactured devices (from the Appliance Efficiency Regulations or Part 6), where applicable.

*[Signature]*  
 Signature, Date

Installing Subcontractor (Co. Name)  
 OR General Contractor (Co. Name) OR Owner

COPY TO: Building Department  
 HERS Provider (if applicable)  
 Building Owner at Occupancy

# KwikKote

No. 200-918808

## Stucco System Installation Card

Job Name: NAPA VALLEY COLLECTION  
Address: 261 ROCK HOUSE CIR NTH  
SACRAMENTO, CA  
Lot #: 0046-17

Stucco System Trade Name: KWIK KOTE  
Stucco System Manufacturer: KWIK KOTE CORP.

ICBO Evaluation Service, Inc.  
Report No. 3607  
Date of Job Completion:

Home Builder: LENNAR RENAISSANCE  
Address: 1075 Creekside Ridge Dr. #100  
ROSEVILLE, CA

Stucco Contractor: KENYON PLASTERING, INC.  
Address: PO BOX 2077  
North Highlands, CA

Telephone Number: 916/349-8191

Approved Contractor Number as  
issued by the Stucco Manufacturer: 1001

Card Print Date: 12/11/2003

This is to certify that the stucco system on the building exterior at the above address had been installed in accordance with the evaluation report specified above and the manufacturer's instructions.

  
\_\_\_\_\_  
Signature of authorized representative of stucco contractor

4-29-04  
\_\_\_\_\_  
Date