

CITY OF SACRAMENTO
1231 I Street, Sacramento, CA 95814

Permit No: 0009856

Insp Area: 2

Site Address: 779 SKYLAKE WY SAC
Parcel No: 030-0600-032

Sub-Type: RES
Housing (Y/N): N

CONTRACTOR
ZIMMERMAN ROOFING
3675 R ST
SACRAMENTO CA 95816

OWNER
BRIAN HING
779 SKYLAKE WAY
SAC CA 95831

ARCHITECT

Nature of Work: REROOF T/O 46SQ PIONEER TILE

CONSTRUCTION LENDING AGENCY: I hereby affirm under penalty of perjury that there is a construction lending agency for the performance of the work for which this permit is issued (Sec. 3097, Civ. C).

Lender's Name _____ Lender's Address _____

LICENSED CONTRACTORS DECLARATION: I hereby affirm under penalty of perjury that I am licensed under provisions of Chapter 9 (commencing with section 7000) of Division 3 of the Business and Professions Code and my license is in full force and effect.

License Class C-39 License Number 557554 Date 8/23/00 Contractor Signature [Signature]

OWNER-BUILDER DECLARATION: I hereby affirm under penalty of perjury that I am exempt from the contractors License Law for the following reason (Sec. 7031.5, Business and Professions Code; any city or county which requires a permit to construct, alter, improve, demolish, or repair any structure, prior to its issuance, also requires the applicant for such permit to file a signed statement that he or she is licensed pursuant to the provisions of the Contractors License Law (Chapter 9 (commencing with Section 7000) of Division 8 of the Business and Professions Code) or that he or she is exempt therefrom and the basis for the alleged exemption. Any violation of Section 7031.5 by any applicant for a permit subjects the applicant to a civil penalty of not more than five hundred dollars (\$500.00);

_____, I, as a owner of the property, or my employees with wages as their sole compensation, will do the work, and the structure is not intended or offered for sale (Sec. 7044, Business and Professional Code: The Contractors License Law does not apply to an owner of property who builds or improves thereon, and who does such work himself or herself or through his/her own employees, provided that such improvements are not intended or offered for sale. If, however, the building or improvement is sold within one year of completion, the owner-builder will have the burden of proving that he/she did not build or improve for the purpose of sale.)

_____, I, as owner of the property, am exclusively contracting with licensed contractors to construct the project (Sec. 7044, Business and Professions Code: The Contractors License Law does not apply to an owner of property who builds or improves thereon, and who contracts for such projects with a contractor(s) licensed pursuant to the Contractors License Law).

I am exempt under Sec _____ B & PC for this reason: _____

Date _____ Owner Signature _____

IN ISSUING THIS BUILDING PERMIT, the applicant represents, and the city relies on the representation of the applicant, that the applicant verified all measurements and locations shown on the application or accompanying drawings and that the improvement to be constructed does not violate any law or private agreement relating to permissible or prohibited locations for such improvements. This building permit does not authorize any illegal location of any improvement or the violation of any private agreement relating to location of improvements.

I certify that I have read this application and state that all information is correct. I agree to comply with all city and county ordinances and state laws relating to building construction and hereby authorize representative(s) of this city to enter upon the abovementioned property for inspection purposes.

Date 8/23/00 Applicant/Agent Signature [Signature]

WORKER'S COMPENSATION DECLARATION: I hereby affirm under penalty of perjury one of the following declarations:

_____, I have and will maintain a certificate of consent to self-insure for workers' compensation as provided for by Section 3700 of the Labor Code, for the performance of work for which the permit is issued.

I have and will maintain workers' compensation insurance, as required by Section 3700 of the Labor Code, for the performance of the work for which this permit is issued. My workers' compensation insurance carrier and policy number are:

Carrier STATE COMP INS FUND Policy Number 713-99-2021 Exp Date 10/01/2000

_____, (This section need not be completed if the permit is for \$100 or less) I certify that in the performance of the work for which this permit is issued, I shall not employ any person in any manner so as to become subject to the workers' compensation laws of California and agree that if I should become subject to the workers' compensation provisions of Section 3700 of the Labor Code, I shall forthwith comply with those provisions.

Date 8/23/00 Applicant Signature [Signature]

WARNING - FAILURE TO SECURE WORKER'S COMPENSATION COVERAGE IS UNLAWFUL AND SHALL SUBJECT AN EMPLOYER TO CRIMINAL PENALTIES AND CIVIL FINES UP TO ONE HUNDRED THOUSAND DOLLARS (\$100,000) IN ADDITION TO THE COST OF COMPENSATION, DAMAGES AS PROVIDED FOR IN SECTION 3706 OF THE LABOR CODE, INTEREST AND ATTORNEY'S FEE.

THIS PERMIT SHALL EXPIRE BY LIMITATION IF WORK IS NOT COMMENCED WITHIN 180 DAYS.

Work req'd per ①, ② & ③
 per report.
 Max 2x6 @ 24" oc span
 is 12'-0" per report.

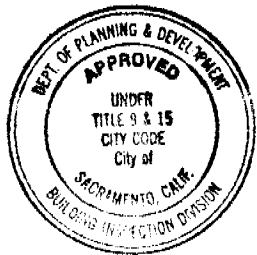
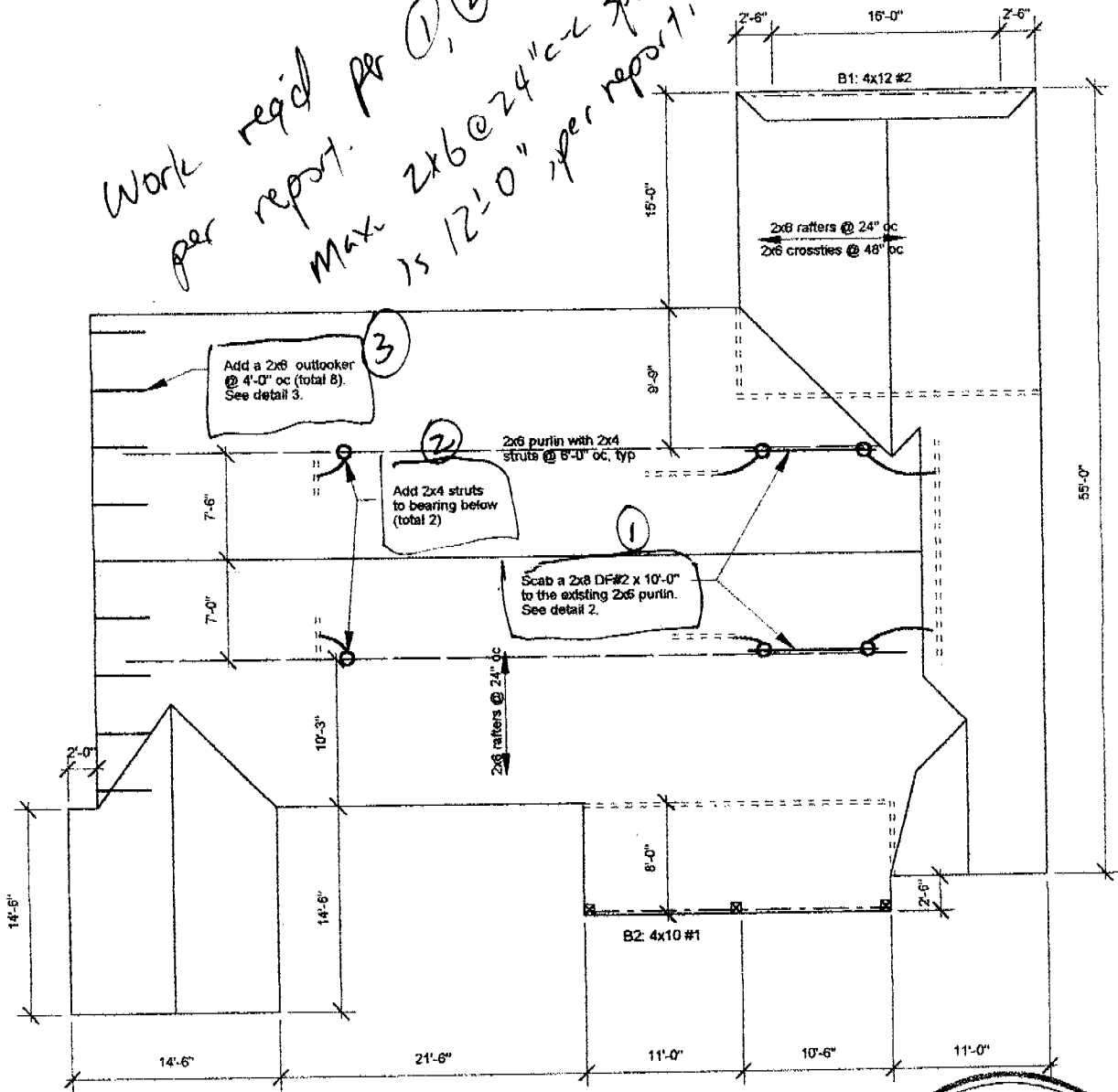

This set of plans and specifications must be kept on the job at all times and it is unlawful to make any changes or alterations from the same without written permission from the Building Inspection Division.

The approval of this plan and specification SHALL NOT be held to permit or authorize any violation of any City Ordinance or State Code. Sacramento Building Division

ISSUED

AUG 23 2000



Reviewed by Matt P. 8/23/00

Notes:

1. This is a reroof project. The new roofing material shall be a Light Weight Concrete Tile. The tile shall weigh less than or equal to 7.0 psf.
2. All rafters are 2x6 DF#2 and hips and valleys are 2x8 DF#2 unless otherwise noted.
3. All existing rafter, hips, valleys, rafter ties, and purlins are braced per UBC Section 2320.12 "Roof and Ceiling Framing" unless otherwise shown.
4. All structural wood members that were observed appear to be in sound condition and without structural defect.

1

ROOF PLAN - HING

Not to Scale

6



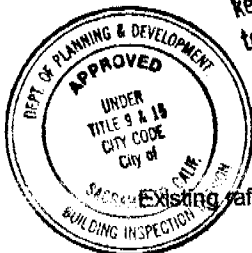

This set of plans and specifications must be kept on the job at all times and it is unlawful to make any changes or alterations from the same without written permission from the Building Inspection Division.
The approval of this plan and specification SHALL NOT be held to permit or approve the violation of any City Ordinance or State Law.

Existing rafters
Existing purlin

Nail purlin to existing purlin w/ 16d @ 3" oc staggered. Shim as required.

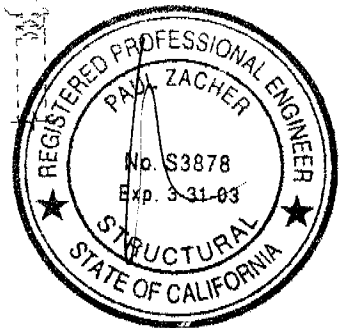
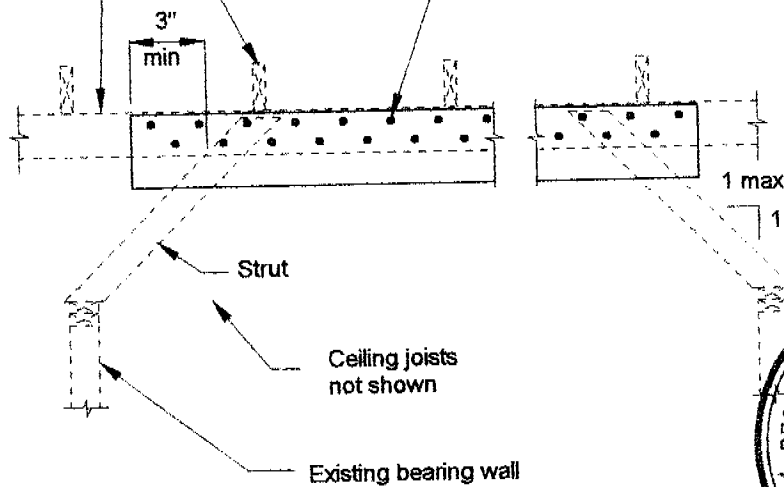

PURLIN DETAIL

2

scale: 1/2" = 1'-0"

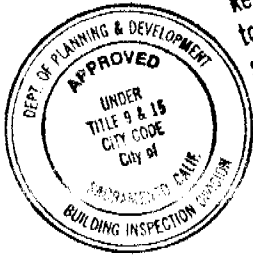

This set of plans and specifications must be kept on the job at all times and it is unlawful to make any changes or alterations from the same without written permission from the Building Inspection Division.
The approval of this plan and specification SHALL NOT be held to permit or approve the violation of any City Ordinance or State Law.

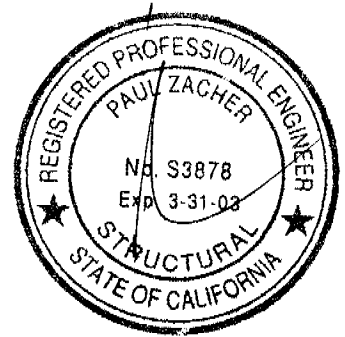
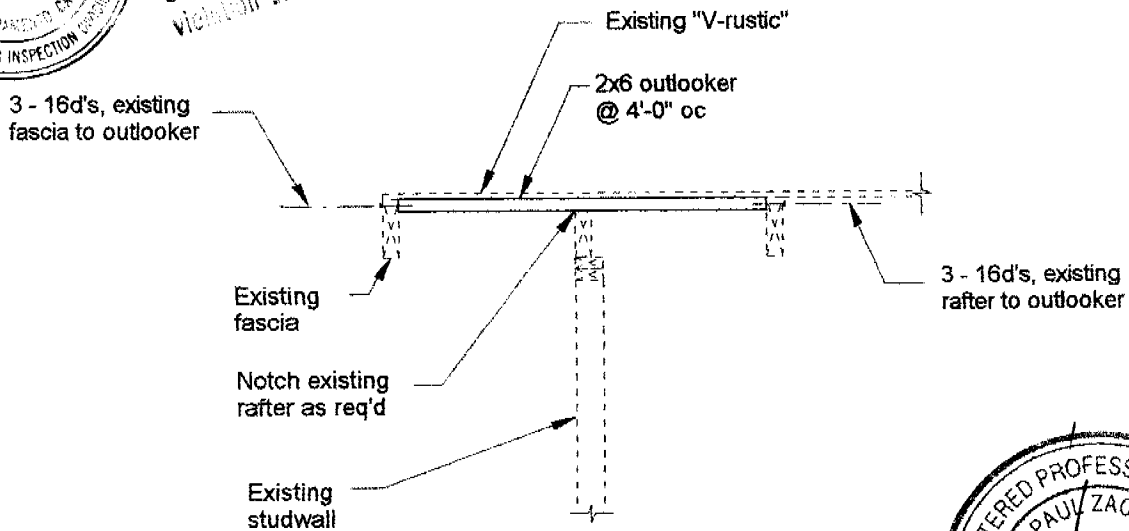

3

DETAIL

scale: 1/2" = 1'-0"

Hing

Paul Zacher - Structural Engineers
4701 Lakeside Way
Fair Oaks, CA 95628

TEL: 916.961.3960
FAX: 916.961.6552

August 21, 2000

Zimmerman Roofing
3675 R Street
Sacramento, CA 95816
TEL: 916.454.3667
FAX: 916.455.3784

Attn.: Mr. Jeff Tucker,

re: Job 2000_248: Hing

Subject: Structural Investigation Report of the Roof for the Residence located at 779 Skylake Way, Sacramento, CA 95831.



As requested by Mr. Jeff Tucker, this is a report to determine what needs should be addressed to correct any structural deficiencies of the roof. Paul Zacher visited the site August 21, 2000. The investigation was made to determine the existing condition of the structure. All information, data and analysis contained within this report are based on the 1997 Uniform Building Code.

The following is based on visual observations with no subsurface investigation being made.

DESCRIPTION:

Type of Facility: Residence.
Year Built: Estimated 1970's vintage.
Occupancy: Residential.
No. of Stories: One.
Dimensions: Approximately 2500 square feet with a first story plate height of 8 feet.

CONSTRUCTION:

Roof:

The roof covering will consist of a Light Weight Concrete Tile over 1/2" solid sheathing. The living area is conventionally framed with 2x6 rafters spaced at 24" on center with 2x6 purlins supported at no more than 8'-0" on center by 2x4 struts bearing on walls below. The garage area is framed with 2x6 rafters spaced at 24" on center and 2x6 cross ties spaced at 4'-0" on center.

CONCLUSIONS:

Roof:

The living area lacks sufficient structural capacity for the applied live and dead loads. The garage has sufficient structural capacity for the applied live and dead loads.

Hing



Paul Zacher - Structural Engineers
4701 Lakeside Way
Fair Oaks, CA 95628

TEL: 916.961.3960
FAX: 916.961.6552

RECOMMENDATIONS:

If any of the following recommendations do not correspond to actual field conditions, the engineer of record shall be notified for further investigation and evaluation before continuing work.

Living Area:

1. Scab a 2x8 DF#2 x 10'-0" long purlin to the existing 2x6 purlin which spans 8'-0". Attach it with 16d's @ 3" on center. Support the 2x8 to the bearing walls below with 2x4 struts. See details 1 and 2.
2. Provide additional 2x4 struts from the existing purlins to the bearing walls below. The maximum spacing between the new and existing struts shall not exceed 6'-0" on center. The unbraced length of the struts shall not exceed 8'-0" and the minimum slope of the struts shall not be less than 45 degrees from the horizontal. See detail 1.
3. Add 2x6 out lookers spaced at 24" on center. See details 1 and 3.

It shall be noted that small hairline cracking may occur at exterior stucco and interior gypboard finished walls that are load bearing or distributing roof strut loads. These cracks are a natural occurrence as the existing structure re-distributes the new roof weight. They are cosmetic in nature and are not an indication of a structural hazard or failure.

It shall be noted that some deflection of the rafters may be evident after installation of the tile. The existing roof framing has deflected but this may not be readily evident due to the uneven nature of the existing roofing material. Concrete tile is a very consistent and uniform product and when installed in an even plane, even small deflections can become apparent. This is only a cosmetic issue and not a structural concern.

The inspection consisted of visual observation only, made solely to determine the structural capacity of the existing roof. Analysis does not determine any effects on the overall structure under lateral forces or effects on the foundation unless specifically noted in the calculations and in this document. No warranties, expressed or implied, are made or intended in conjunction with this report. The inspection was made only to the portions that were accessible. The specific items noted were those that were observable and there may be defects which are not observable, or are hidden by architectural and structural materials.

If you have any questions on the above, do not hesitate to call.

Sincerely,

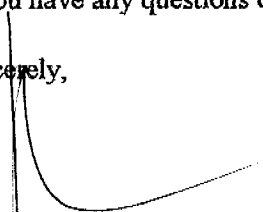

Paul Zacher, P.E., S.E.
file

DESIGN LOADING:

Roof Pitch	4	in 12
Pitch Adjustment Factor	1.05	

LOCATION: ROOF

<u>MATERIAL</u>		<u>WEIGHT</u>	
Light Weight Tile		7.00	psf
Roofing felt		0.30	psf
1/2" OSB/ plywood		1.50	psf
1x4 skip sht'g		1.09	psf
2x6 rafters @ 24" oc		<u>1.00</u>	psf
	Load	10.9	psf
	Roof Pitch Adjustment	<u>0.59</u>	psf
	Total Load	11.5	psf

M

Job #: 00-240

Date: 8/21/00

LOADING

EAFTEZ

$D_p = 11.5 \text{ psf} \times 2' = 23 \text{ psf}$

$2 \times 6'' \times 2$

$L_p = 16.0 \dots = 32'$

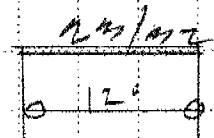

X21

$D_p = 11.5 \text{ psf} \times 4' = 46 \text{ psf}$

$4 \times 12'' \times 2$

$L_p = 16.0 \dots = 64'$

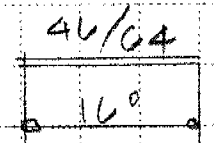

X22

$D_p = 11.5 \text{ psf} \times 4' = 46 \text{ psf}$

$4 \times 10'' \times 1$

$L_p = 16.0 \dots = 64'$

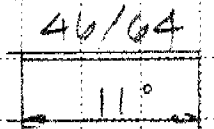

PURLIN

$D_p = 11.5 \text{ psf} \times 8' = 100 \text{ psf}$

$2 \times 6'' \times 2 +$

$L_p = 16.0 \dots = 140'$

$2 \times 8'' \times 2$

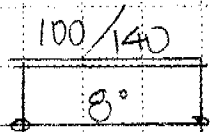

Paul Zacher - Structural Engineers
 4701 Lakeside Way
 Fair Oaks
 TEL: (916) 961-3960
 FAX: (916) 961-6552

Title :
 Dsgnr:
 Description :

Job #
 Date: 10:53AM, 21 AUG 00

Scope :

Rev. 510304
 User: KW-0602844, Var 5.1.3, 22-Jun-1999, Win32
 (c) 1983-99 ENERCALC

Timber Beam & Joist

c:\enercalc\test.ecw:Calculations

Description RAFTERS AND BEAMS

Timber Member Information

Calculations are designed to 1997 NDS and 1997 UBC Requirements

	rafter	B1	B2	purlin
Timber Section	2x6	4x12	4x10	2x6 +2x8
Beam Width	in 1.500	3.500	3.500	3.000
Beam Depth	in 5.500	11.250	9.250	6.500
Le: Unbraced Length	ft 0.00	0.00	0.00	0.00
Timber Grade	Douglas Fir - Larch, Douglas Fir - Larch, Douglas Fir - Larch, Douglas Fir - Larch,			
Fb - Basic Allow	psi 875.0	875.0	1,000.0	875.0
Fv - Basic Allow	psi 95.0	95.0	95.0	95.0
Elastic Modulus	ksi 1,600.0	1,600.0	1,700.0	1,600.0
Load Duration Factor	1.250	1.250	1.250	1.250
Member Type	Sawn	Sawn	Sawn	Sawn
Repetitive Status	Repetitive	No	No	No

Center Span Data

Span	ft	12.00	16.00	11.00	8.00
Dead Load	#/ft	23.00	46.00	46.00	100.00
Live Load	#/ft	32.00	64.00	64.00	140.00

Results

Ratio = 0.9607 0.4755 0.2667 0.7671

Mmax @ Center	in-k	11.88	42.24	19.96	23.04
@ X =	ft	6.00	8.00	5.50	4.00
Fb : Actual	psi	1,570.9	572.1	400.0	1,090.7
Fb : Allowable	psi	1,635.2	1,203.1	1,500.0	1,421.9
		Bending OK	Bending OK	Bending OK	Bending OK
Fv : Actual	psi	55.7	29.8	24.2	64.4
Fv : Allowable	psi	118.8	118.8	118.8	118.8
		Shear OK	Shear OK	Shear OK	Shear OK

Reactions

@ Left End	DL	lbs	138.00	368.00	253.00	400.00
	LL	lbs	192.00	512.00	352.00	560.00
	Max. DL+LL	lbs	330.00	880.00	605.00	960.00
@ Right End	DL	lbs	138.00	368.00	253.00	400.00
	LL	lbs	192.00	512.00	352.00	560.00
	Max. DL+LL	lbs	330.00	880.00	605.00	960.00

Deflections

Ratio OK Deflection OK Deflection OK Deflection OK

Center DL Defl	in	-0.322	-0.102	-0.039	-0.084
L/Defl Ratio		446.5	1,880.9	3,418.5	1,144.3
Center LL Defl	in	-0.449	-0.142	-0.054	-0.117
L/Defl Ratio		320.9	1,351.9	2,457.0	817.4
Center Total Defl	in	-0.771	-0.244	-0.092	-0.201
Location	ft	6.000	8.000	5.500	4.000
L/Defl Ratio		186.7	786.5	1,429.6	476.8