

CITY OF SACRAMENTO
1231 I Street, Sacramento, CA 95814

Permit No: 0107820
Insp Area: 4

Site Address: 4820 VERENA LN SAC
Parcel No: 225-1610-066 WESTBR 6 LOT 66

Sub-Type: NSFR
Housing (Y/N): N

CONTRACTOR
MORRISON HOMES
1130 IRON POINT RD STE 120
FOLSOM CA 95630

OWNER
MORRISON HOMES
1130 IRON POINT RD #120
FOLSOM CA 95630

ARCHITECT

Nature of Work: NSFR MP1958 8 RMS

CONSTRUCTION LENDING AGENCY: I hereby affirm under penalty of perjury that there is a construction lending agency for the performance of the work for which this permit is issued (Sec. 3097, Civ. Code).

Lender's Name _____ Lender's Address _____

LICENSED CONTRACTORS DECLARATION: I hereby affirm under penalty of perjury that I am licensed under provisions of Chapter 9 commencing with section 7000 of Division 3 of the Business and Professions Code and my license is in full force and effect.

License Class B License Number 519465 Date 6/29/01 Contractor Signature 

OWNER-BUILDER DECLARATION: I hereby affirm under penalty of perjury that I am exempt from the contractors License Law for the following reason (Sec. 7031.5, Business and Professions Code; any city or county which requires a permit to construct, alter, improve, demolish, or repair any structure, prior to its issuance, also requires the applicant for such permit to file a signed statement that he or she is licensed pursuant to the provisions of the Contractors License Law (Chapter 9 commencing with Section 7000) of Division 8 of the Business and Professions Code) or that he or she is exempt therefrom and the basis for the alleged exemption. Any violation of Section 7031.5 by any applicant for a permit subjects the applicant to a civil penalty of not more than five hundred dollars (\$500.00).

I, as a owner of the property, or my employees with wages as their sole compensation, will do the work, and the structure is not intended or offered for sale (Sec. 7044, Business and Professional Code). The Contractors License Law does not apply to an owner of property who builds or improves thereon, and who does such work himself or herself or through his/her own employees, provided that such improvements are not intended or offered for sale. If, however, the building or improvement is sold within one year of completion, the owner-builder will have the burden of proving that he/she did not build or improve for the purpose of sale.

I, as owner of the property, am exclusively contracting with licensed contractors to construct the project (Sec. 7044, Business and Professions Code). The Contractors License Law does not apply to an owner of property who builds or improves thereon, and who contracts for such projects with a contractor(s) licensed pursuant to the Contractors License Law.

I am exempt under Sec. _____ B & PC for this reason: _____

Date _____ Owner Signature _____

IN ISSUING THIS BUILDING PERMIT, the applicant represents, and the city relies on the representation of the applicant, that the applicant verified all measurements and locations shown on the application or accompanying drawings and that the improvement to be constructed does not violate any law or private agreement relating to permissible or prohibited locations for such improvements. This building permit does not authorize any illegal location of any improvement or the violation of any private agreement relating to location of improvements.

I certify that I have read this application and state that all information is correct. I agree to comply with all city and county ordinances and state laws relating to building construction and hereby authorize representative(s) of this city to enter upon the above mentioned property for inspection purposes.

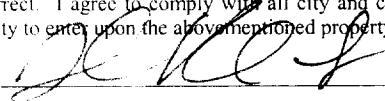
Date 6/29/01 Applicant Agent Signature 

WORKER'S COMPENSATION DECLARATION: I hereby affirm under penalty of perjury one of the following declarations:

I have and will maintain a certificate of consent to self-insure for workers' compensation as provided for by Section 3700 of the Labor Code, for the performance of work for which the permit is issued.

R I have and will maintain workers' compensation insurance, as required by Section 3700 of the Labor Code, for the performance of the work for which this permit is issued. My workers' compensation insurance carrier and policy number are:

Carrier ZURICH-AMERICAN INS CO Policy Number WC2090701-03 Exp Date 11/01/2001

(This section need not be completed if the permit is for \$100 or less) I certify that in the performance of the work for which this permit is issued, I shall not employ any person in any manner so as to become subject to the workers' compensation law of California and agree that if I should become subject to the workers' compensation provisions of Section 3700 of the Labor Code, I shall forthwith comply with those provisions.

Date 6/29/01 Applicant Signature 

WARNING: FAILURE TO SECURE WORKER'S COMPENSATION COVERAGE IS UNLAWFUL AND SHALL SUBJECT AN EMPLOYER TO CRIMINAL PENALTIES AND CIVIL FINES UP TO ONE HUNDRED THOUSAND DOLLARS (\$100,000) IN ADDITION TO THE COST OF COMPENSATION, DAMAGES AS PROVIDED FOR IN SECTION 3706 OF THE LABOR CODE, INTEREST AND ATTORNEY'S FEE.

THIS PERMIT SHALL EXPIRE BY LIMITATION IF WORK IS NOT COMMENCED WITHIN 180 DAYS.

RESIDENTIAL SUBDIVISION BUILDING PERMIT APPLICATION

Project Address: 4820 Verena Lane Assessor Parcel # 225-1610-066
Lot Number: 66 Subdivision Westborough Village

OWNER INFORMATION:

Legal Property Owner: Morrison Homes Phone# (916) 355-8900
Owner Address: 1130 Iron Point Rd #120 City Folsom State CA Zip 95630

CONTRACTOR INFORMATION:

Contractor: Morrison Homes Lic. # 519465 Phone # 355-8900 Fax 355-0100

PROJECT INFORMATION:

Land Use Zone R1A Occupancy Group R3 Construction Type VN Fed Code 1A
No. of Stories: 1 No. of Rooms: 8 Street Width: 40'
1st Floor Area 1958 2nd Floor Area 0 Basement _____ Roof Material _____

AREA IN SQUARE FOOT OF:

Dwelling/Living 1958
Garage/Storage 637
Decks/Balconies 190
Carpports _____

SCOPE OF WORK: New Single Family Dwelling

FOR OFFICE USE ONLY

- Information Above Complete
- Violation Files Checked
- Standard Setbacks
- County Sewer
- AR Flood Waiver Required
- Flood Elevation Certificate Required
- Water Development Infill Area
- Planning Approval
- Design Review Approval
- Special Fee Districts Apply:

THE FOLLOWING MUST BE PROVIDED IN ORDER TO SUBMIT FOR PERMIT

- 2 COMPLETE PLOT PLANS, LEGIBLE & DRAWN TO SCALE
- 11 X 17 COPY OF FLOOR PLAN WITH FOLLOWING INFORMATION
 - a) Assessors Parcel Number
 - b) New Floor Area
 - c) Owners Name
 - d) Project Address

Date: _____ Received by: (staff) _____ Permit # _____

*Provide protection
From Vehicle*
GARAGE
INVERTER ST2500XR
48VDC, 240VAC

SUNSLATE ROOF 2.3KW TMAX
FIELD CABLE SPLICE BOX
LOCATED IN ATTIC
ROOF PENETRATION

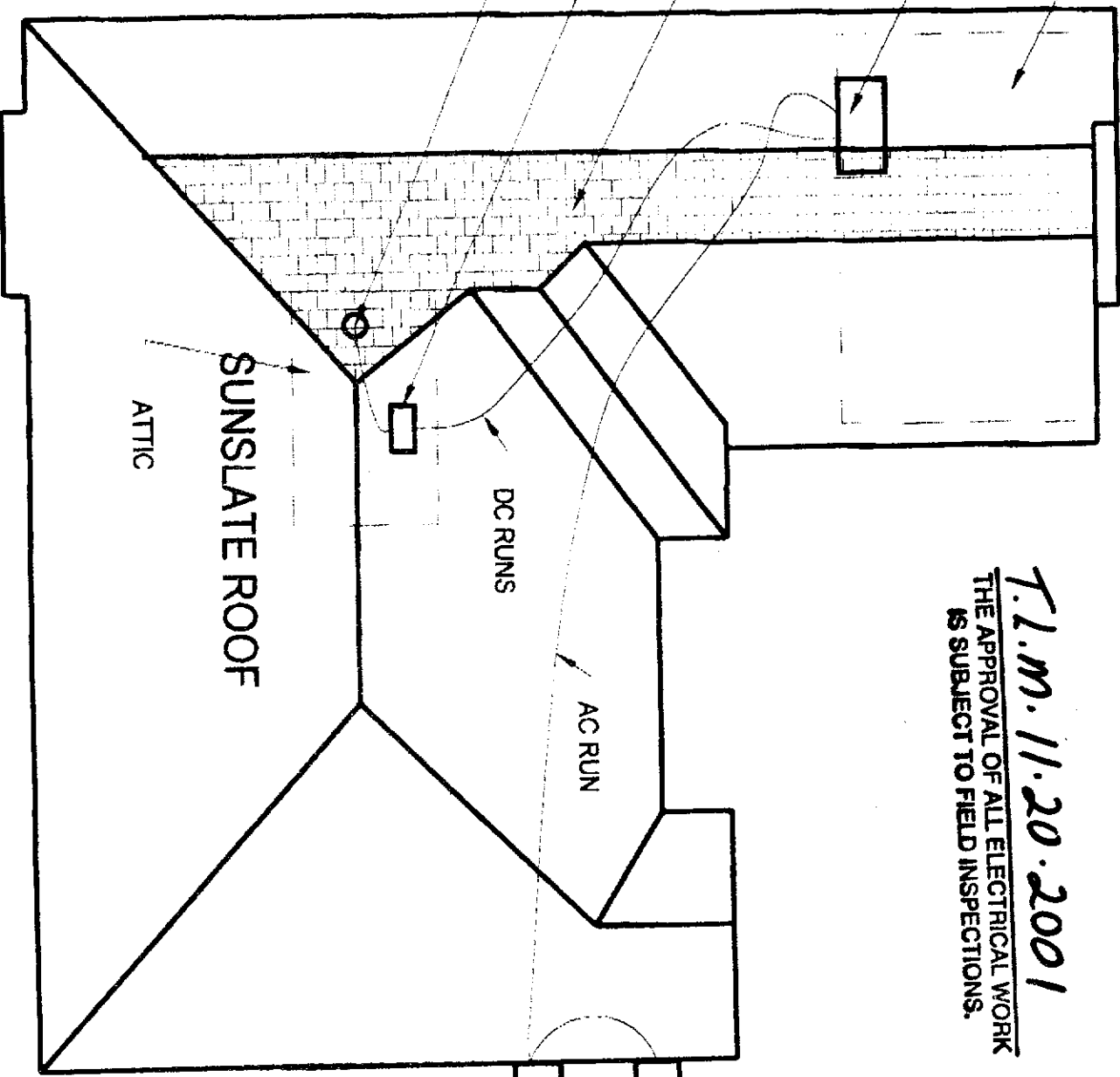

T.L.M. 11.20.2001
THE APPROVAL OF ALL ELECTRICAL WORK
IS SUBJECT TO FIELD INSPECTIONS.

JOB COPY

MORRISON BEL LAGO PLAN#1958

4820 Venerable

Permit # 0107820

LOT#66

ATLANTIS ENERGY Inc.

Project Name: 240 Sunslate Package

System Design

Offer S-01.10.S1

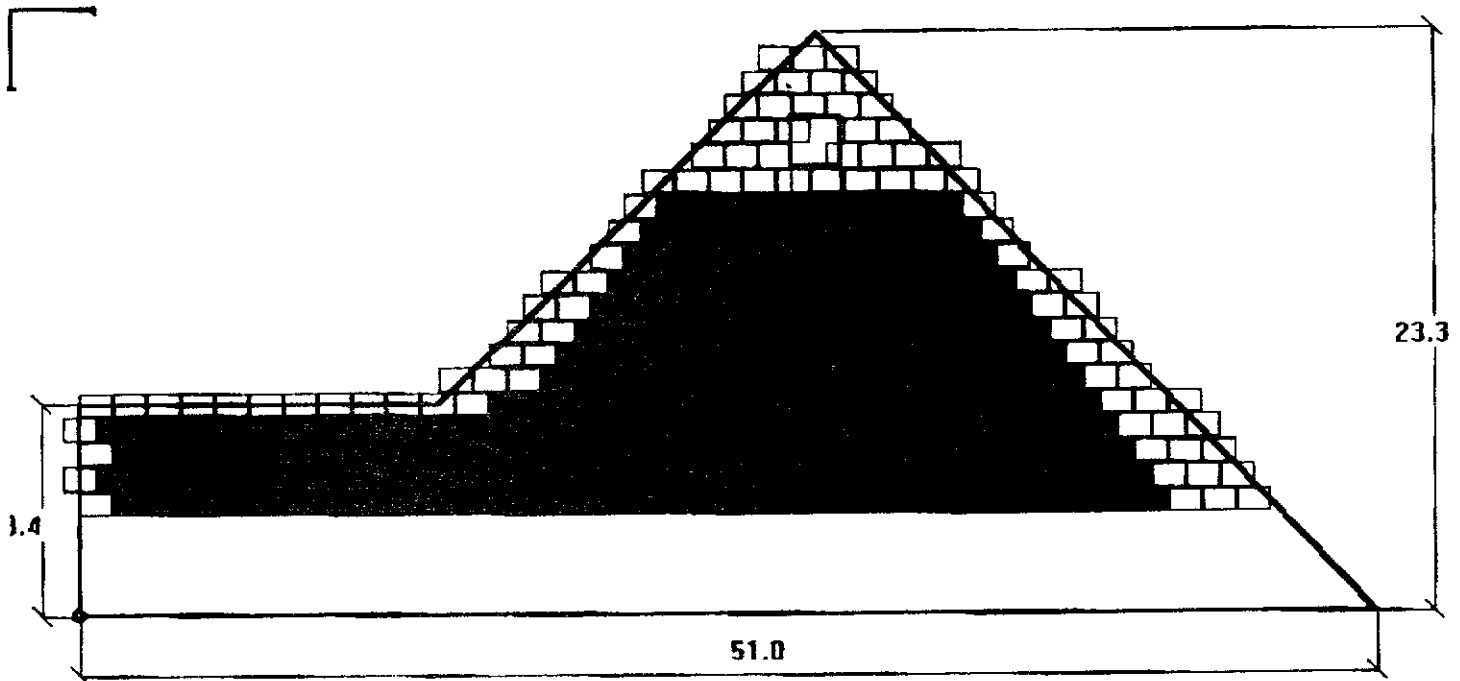

THE APPROVAL OF ALL ELECTRICAL WORK
IS SUBJECT TO FIELD INSPECTIONS.

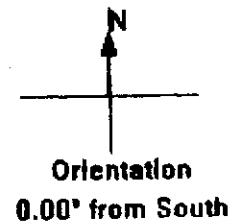

Total installed power DC @ STC:	2,928	[W]
Total installed power AC @ PTC:	2,213	[W]
Sunslates surface:	310.0	Sq.Ft.

240 - SUNSLATES® SYSTEM

240 - SUNSLATES® SYSTEM PACKAGE SPECIFICATIONS

Maximum Surface	415	Sq.Ft.
Minimum Surface	355	Sq.Ft.
SUNSLATES® Surface	311	Sq.Ft.
SUNSLATES® Power @ STC	2.93	kWatts

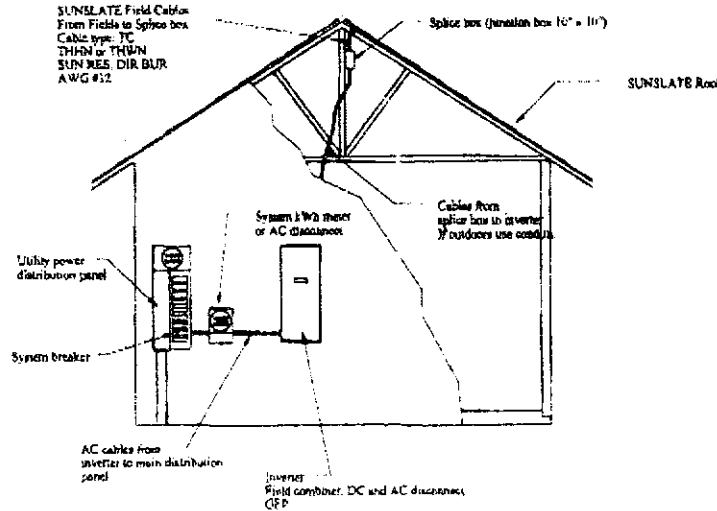

MATERIALS

ROOF	SUNSLATES® /w cables	SM-II	240
	Field cables	Max 50' each	10
	Bridge cables	Field loop	12
	Twister cables	Row to row cable	16
	Shields	Strain relief	250
	Silicone sealant	Shin-Etsu, 1 component RTV- tube	3
	'Eternit' slates	40 x 72	80
	'Eternit' starters	40 x 42	42
	Hooks	200 per box	2
	Installation tool	'T' type	2
	Battens - vertical	2 x 2 in feet	--
	Battens - horizontal	1 x 4 in feet	--
NOTE: Other materials required for roof installation (as flashing, ridge covers...etc.) will be ordered and billed as needed. Does not include roof under-laymen's (as plywood, roofing felt...etc.). Wood price may vary depending on market prices.			
ELECTRICAL	DC to AC Inverter	ST 2500 XR/ 240, 3 wire	1
	Pull box / splice box	10" x 10" with terminal strips	1
	Field combiner box /w fuses	TCB - 10 /10 inputs	1
	Meter base or disconnect	4 Jaw meter base	1
	System breaker	15 Amp / 240 Volt	1
	DC meter / DC amps and DC volts	500 VDC, 10 ADC	1
NOTE: Cables from splice box to inverter (12 total) and from inverter to beaker panel are to be provided by contractor. For cable sizing review the table below. Other materials required for electrical installation (as conduits, pull boxes, cables, fittings...etc.) are not included.			

THIS DOCUMENT IS UNCLASSIFIED
DATE 08/11/2010 BY 60322 UCBAW

240 - SUNSLATES® SYSTEM

SUNSLATES® SPECIFICATIONS:

One SUNSLATE®

SUNSLATES® Model	P _{max} Watts	V _{max} Volts	V _{oc} Volts	I _{max} Amps	I _{sc} Amps
SM-II	12.20	2.86	3.67	4.30	4.72

Field of 24 SUNSLATES® in series (String)

SUNSLATES® Model	P _{max} Watts	V _{max} Volts	V _{oc} Volts	I _{max} Amps	I _{sc} Amps
24 - SM-II	292.8	68.64	88.08	4.30	4.72

System of 10 SUNSLATES® fields in parallel

SUNSLATES® Model	P _{max} Watts	V _{max} Volts	V _{oc} Volts	I _{max} Amps	I _{sc} Amps
24 - SM-II	2,928.0	68.64	88.08	43.0	47.2

The system is designed for a 48VDC nominal voltage. The electrical characteristics are within ±10 percent of the indicated values of I_{sc}, V_{oc} and P_{max} under standard test conditions (1000 W/m² irradiance, 25 degC (77 degF) cell temperature and AM 1.5 spectrum). Under normal conditions, the SUNSLATE™ is likely to experience conditions that produce more current and/or voltage than reported at standard test conditions (output may vary depending on time of day, time of year, ambient conditions, ambient temperature and shading). Accordingly, the value of I_{sc} and V_{oc} marked on the SUNSLATE should be multiplied by a factor 1.25 when determining component voltage ratings, conductor ampacities, fuse size and the size of controls connected to the PV output.

SYSTEM DESCRIPTION

The grid connected power systems consist from:

- Installed SUNSLATES®
- Cables
- DC to AC inverter
- Load (building AC loads from distribution panel).

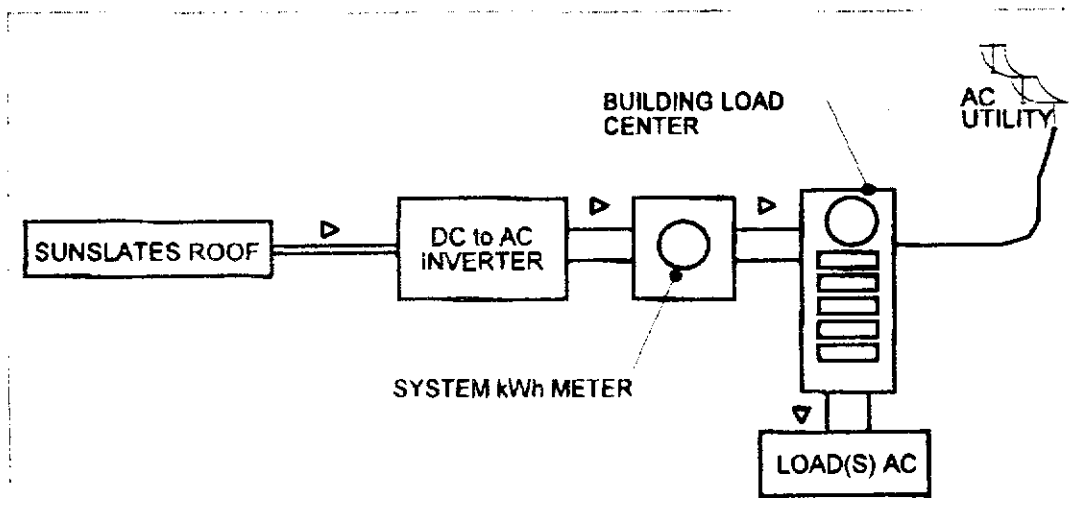

THE APPROVAL OF ALL ELECTRICAL CONNECTIONS IS SUBJECT TO FIELD INSPECTIONS

240 - SUNSLATES® SYSTEM

This is one of the most common SUNSLATES® system designs. Saving the energy is done by back feeding the utility grid with the generated power. The system will generate electricity in the day, run the kWh meter backwards, building up a credit (if access power is generated) and the building will use this credit at night.

The building (roof) on which the SUNSLATES® are installed is setup from SUNSLATES® fields (strings). All the fields are installed with an equal number of SUNSLATES® in them (24 SUNSLATES®). The field has a beginning (bridge cable) and an end (field connecting cable). When installing the field, always start (first SUNSLATES® from the string) with bridge cable and end with field connecting cable, which goes through the roof into the building. The "System Design" document (see appendix 2), will show how many fields are needed and the position of every field.

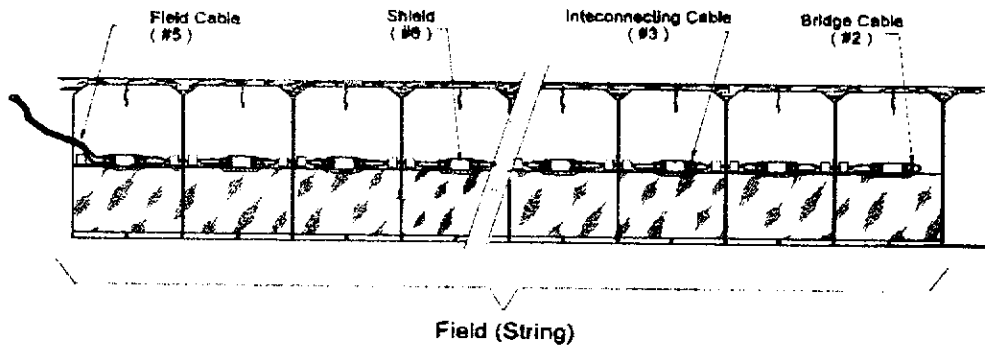

For SUNSLATES® installation details refer to 'SUNSLATES® INSTALLATION MANUAL' Part # MN100

The fields are then extended using pre-installed cables at the splice box, which is located in a convenient location. The pre-installed cables are mounted run to the inverter where they are combined in parallel. The inverter will transform the DC power into AC matching the utility grid. The produced power will be back-fed into the main electrical distribution panel of the building and if not used by any load from the building will be led back to the utility grid by rotating back the utility's kWh-meter. The additional kWh meter is for monitoring the SUNSLATES® system performance only.

SYSTEM WIRING

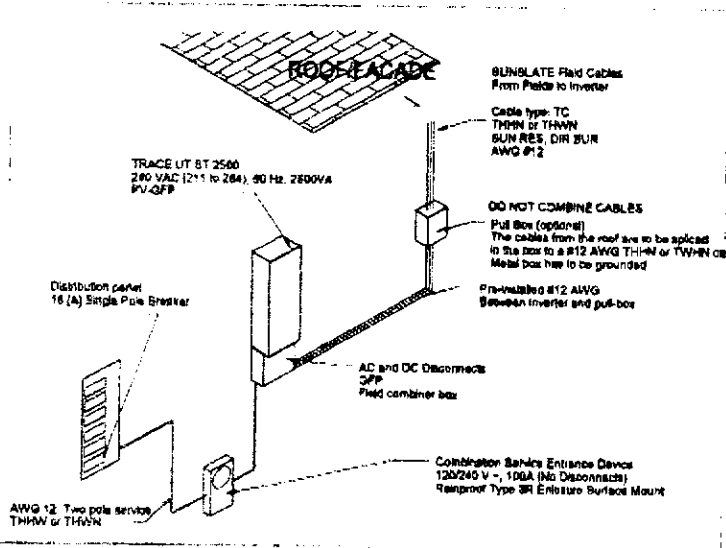

THE APPROVAL OF THE ELECTRICAL WORK IS SUBJECT TO FIELD INSPECTION.

240 - SUNSLATES® SYSTEM

AC LINE DIAGRAM

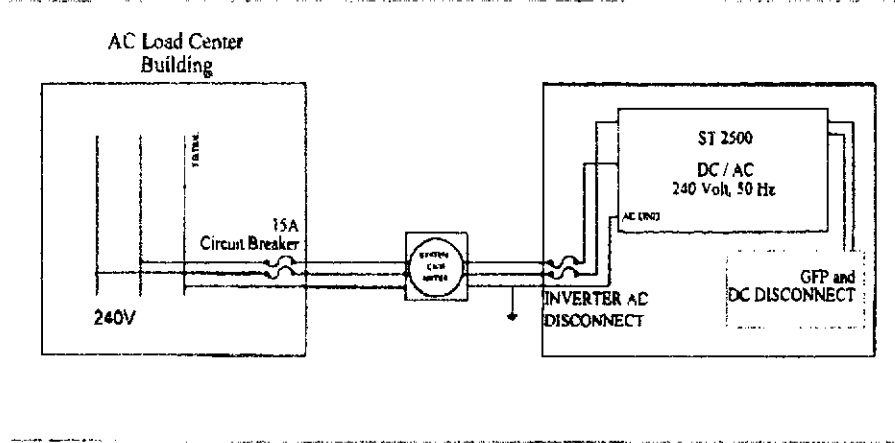

The inverter system consists from:

- DC to AC converter
- Field combiner board
- GFP on the DC side
- DC and AC inverter disconnects

All components are UL listed and pre-installed to comply with NEC section 690. The inverter comes pre-wired and in a wall mount NEMA3R enclosure.

See inverter specifications and installation manual for details

DC WIRE SIZING TABLE

All DC conductors are to be sized using the table below. The voltage drop will be no greater than 1.5% from maximum conditions. Refer to 310-15 and 310-16 of NEC (1996) for correction factors.

Gauge A.W.G.	R @ 77 Ohms Per 1000'	R @ 148 Ohms per 1000'	Diameter in mils 1000th in.	@ 77 degF		@ 148 degF		Metallic Conduit		Gauge A.W.G.
				Maximum Length for Field	Maximum Length for System	Maximum Length for Field	Maximum Length for System	Number of Conductors 2	Number of Conductors 4	
000	0.063	0.073	410	1571	131	1356	113	1.5"	2"	000
00	0.079	0.092	365	1253	104	1076	90	1.25"	2"	00
0	0.1	0.116	325	990	82	853	71	1.25"	1.5"	0
1	0.126	0.146	289	785	65	678	56	1.25"	1.5"	1
2	0.159	0.184	258	622	52	536	45	1"	1.25"	2
4	0.253	0.292	204	391	33	339	28	0.75"	1"	4
6	0.403	0.465	162	246	20	213	18	0.5"	0.75"	6
8	0.641	0.739	128	154	13	134	11	0.5"	0.75"	8
10	1.02	1.18	102	97	8	84	7	0.5"/6	0.5"/6	10
12	1.62	1.87	97	61	5	53	4	0.5"/9	0.5"/9	12

NOTE: All dimensions for length are in feet (1' = 0.3048 m). Length is for a cable of two conductors (positive and negative). Refer to NEC and local building codes for conduit type, installation and grounding. Wire conductor type: THHN, THWN or THWN-2. Based on 1.5% DC voltage drop.

THE APPROVAL OF ALL ELECTRICAL WORK IS SUBJECT TO FIELD INSPECTIONS.



Sun Tie

UTILITY INTERACTIVE SOLAR ELECTRIC INVERTER

MODEL	ST1000	ST1500	ST2000	ST2500
AC voltage-nominal	240 VAC			
Maximum power point tracking voltage range	42-85 VDC			
Minimum input DC voltage (for full rated AC output)	62 VDC (typically, four nominal 12 VDC PV modules, in series)			
Minimum wake-up DC input voltage	80 VDC			
Absolute maximum PV open circuit voltage	125 VDC			
AC voltage-min/max	211-284 VAC			
AC output characteristics	Current source			
Nominal frequency	60 Hz			
Frequency window-min/max	59.5/60.5 Hz Default			
Continuous AC output @ 25 °C	1.0 kVA	1.5 kVA	2.0 kVA	2.5 kVA
Efficiency-peak	92%		94%	
AC output waveform	Sine wave, high frequency PWM controlled			
Total harmonic distortion	Less than 5% at rated power per IEEE 929 and UL 1741			
AC disconnect	Double-pole 16 amp, 240 VAC branch circuited rated breaker			
DC disconnect	Single-pole 100 amp DC rated circuit breaker			
Islanding protection	Over/under AC voltage and frequency detection plus active islanding detection-meets IEEE 929 and UL 1741 requirements			
User display	Backlight alphanumeric LCD display-AC amps, AC volts _{rms} , DC volts, AC frequency, output power (W) and (Wh) produced			
Specified temperature range	-58-113 °F (-50-45 °C)			
Enclosure Type	Outdoor, rainproof, powder coated aluminum enclosure, fully screened			
Dimensions (inverter only)	13.25" W x 33.20" H x 8.3" D (33.8 cm W x 83.1 cm H x 13.25 cm D)			
Dimensions (shipping)	15.75" W x 37.78" H x 9.5" D (39.4 cm W x 94.4 cm H x 23.8 cm D)			
Weight (inverter only)	35 lb. (15.9 kg)			
Weight (shipping)	40 lb. (18 kg)			
Mounting	Vertical wall mount only			
Listings	UL listed to UL1741, 1st edition and cUL listed to CSA C22.2 No. 107.1-95			
STANDARD FEATURES AND OPTIONS				
PV ground and fault protection system	-	Standard	-	Standard
PV combiner board with 6 fused inputs, 20 amps maximum per input	-	Standard	-	Standard
Burge arrester-Combined AC/DC protection	Standard	Standard	Standard	Standard
Rain Shield (STRS) Protective rain shield (required for outdoor installation)	Optional	Optional	Optional	Optional

Specifications subject to change without notice.
Specifications @ 25 °C.

liable From:

THE APPROVAL OF ALL ELECTRICAL WORK IS SUBJECT TO FIELD INSPECTIONS.

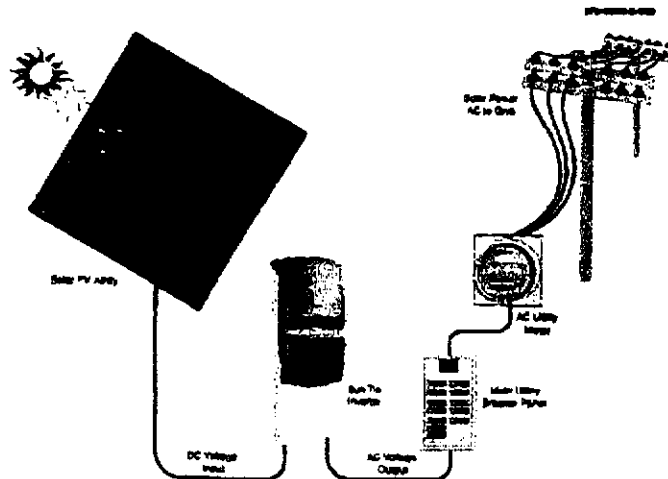

The Sun Tie connects all the elements of a utility interactive solar electric system together.

TRAY CABLE**THHN INSULATION - PVC JACKET
600 VOLT - 90 C - TYPE VNTC**

Vinyl nylon tray cable was developed in the late 1970's with the goal of low cost, small outside diameter, and flame retardance. It can be used as power and control cable with a multitude of applications. The most common application is for use in cable trays and raceways, but tray cable is also direct burial rated and sunlight resistant. VNTC can also be lashed to a messenger for use aerially.

Vinyl nylon tray cable has THHN or TFFN inner conductors and a polyvinylchloride jacket overall. The PVC jacket can be rated to pass the IEEE Flame Test at 70,000 BTU or 210,000 BTU depending upon requirements.

Available in the following color codes: (See page 70 for specific color code charts)

- Method 1 (K1)
- Method 1 (K2)
- Method 4

APPROVALS

- UL Listed Type TC per UL 1277.
- Passes IEEE Flame Test at 70,000 BTU (also available rated at 210,000 BTU)
- NEC Article 318 for tray installation.
- NEC Article 340 for cable construction.
- Direct Burial Rated
- Sunlight Resistant
- Temperature Rated 75 C for Wet Locations, 90 C for Dry Locations

The specification sheets that follow should be used as a guide to the most common stock constructions for each gauge size. Omni Cable has the technical expertise and manufacturing capabilities to satisfy virtually any requirement or construction. Omni Cable's unique ability in specialty cable is unmatched in the wire and cable industry.

TYPE VNTC - THHN INSULATION PVC JACKET - 90 C - 600 VOLT



TRAY CABLE

600 VOLT - 90 C DRY - 75 C WET - DIRECT BURIAL RATED

CONSTRUCTION

Conductor: Stranded bare copper Class B per UL 83.
Insulation: Extruded polyvinylchloride to UL requirements for Class THHN and THW insulation, which with nylon jacket is approved for Type THHN and THWN wires per UL 83.
Assembly: The conductors are cabled with fillers where needed to make a round compact core and a suitable tape is applied over the construction.
Conductor Identification: Individual conductors are color coded per Method 1 (K-2) with surface print.
Jacket: Black sunlight resistant, flame retardant polyvinylchloride per UL 1277 requirements for Type TC power and control cables.

APPLICATIONS

- Control circuits for operation and interconnection of protective and signaling devices, and for general use in manufacturing, industrial and commercial distribution systems.
- U.L. listed and labeled for installation in ladders, trough, channels, solid bottom trays and other similar structures (NEC Articles 318 and 340), and in duct, conduit, wireways and all other installations approved for building wire.
- In hazardous locations per NEC Articles 500 and 501. May be used in wet or dry locations, sunlight resistant, and suitable for direct burial.

STANDARDS

- Temperature Rating 75 C Wet Locations, 90 C Dry Locations.
- U.L. Listed Type TC Cable per UL 1277.
- Passes IEEE Flame Test at 70,000 BTU
- NEC Article 318 for tray installation.
- NEC Article 340 for cable construction.

Part #	AWG Size	No. of Cond.	Nom. Insul. Thickness	Nylon Thickness	Nom. Jacket Thickness	Nom. O.D.	Lbs/M
A11002F	10	2	.015"	.004"	.045"	280" x .430"	118
A11002	10	2	.015"	.004"	.045"	.435"	120
A11003	10	3	.015"	.004"	.045"	.480"	165
A11004	10	4	.015"	.004"	.045"	.535"	210
A11005	10	5	.015"	.004"	.060"	.590"	270
A11007	10	7	.015"	.004"	.060"	.655"	355
A11009F	10	9	.015"	.004"	.060"	.735"	465
A11012	10	12	.015"	.004"	.060"	.830"	585
A11019	10	19	.015"	.004"	.080"	1.215"	1050



Part No.	AWG Size	No. of Cond	Nom. Insulation Thickness	Nylon Thickness	Nom. Jacket Thickness	Nominal O.D.	Lbs./M'
A11202F(flat)	12	2	.015"	.004"	.045"	.260" x .365"	73
A11202	12	2	.015"	.004"	.045"	.365"	75
A11203	12	3	.015"	.004"	.045"	.385"	110
A11204	12	4	.015"	.004"	.045"	.421"	135
A11205	12	5	.015"	.004"	.045"	.460"	165
A11206	12	6	.015"	.004"	.045"	.505"	189
A11207	12	7	.015"	.004"	.045"	.541"	218
A11209	12	9	.015"	.004"	.045"	.610"	295
A11212	12	12	.015"	.004"	.045"	.685"	378
A11215	12	15	.015"	.004"	.045"	.765"	466
A11219	12	19	.015"	.004"	.045"	.800"	565
A11220	12	20	.015"	.004"	.045"	.895"	412
A11225	12	25	.015"	.004"	.045"	1.008"	760
A11230	12	30	.015"	.004"	.045"	1.026"	935
A11237	12	37	.015"	.004"	.045"	1.108"	1089

PHILADELPHIA
 (610) 701-0100

BOSTON
 (781) 986-0687

ATLANTA
 (770) 923-7033

ST. LOUIS
 (636) 272-6664

SAN FRANCISCO
 (510) 887-8600

HOUSTON
 (713) 692-2929

LOT 66

OMEGA PRODUCTS INTERNATIONAL, INC.

DIAMOND WALL INSULATING STUCCO SYSTEM

JOB ADDRESS:

ICBO Report #4004

4820 VERENA LANE

SACRAMENTO, CA 95835

Date of Job Completion OCT 10, 2001

PLASTERING CONTRACTOR:

Name: STULLO WORKS INC

Address: 5900 WAREHOUSE WAY SACRAMENTO CA

Telephone No: (916) 383 66 99

Contractor Number of Diamond Wall System 2175

This is to certify that the exterior coating system on the building exterior at the above address has been installed in accordance with the evaluation report specified above and the manufacturer's instructions.

Date OCT 12, 2001

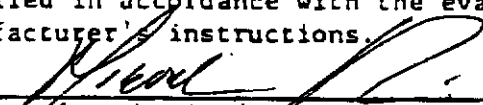
Signature of authorized representative of
Plastering Contractor

This installation card must be presented to the building inspector after completion of work and before final inspection.

CERTIFICATION OF INSULATION

PART I GENERAL

ADDRESS OR TRACT Morrison Homes 4820 VERONIA LANE Bel-Ago. S.A.T.O. 95835	LOT # 66	SACRAMENTO INSULATION CONTRACTORS <input type="checkbox"/> P.O. BOX 854, WEST SACRAMENTO, CA 95691 LIC. #202026 <input type="checkbox"/> 1309 MELODY ROAD, MARYSVILLE, CA 95901 LIC. #202026 <input type="checkbox"/> P.O. BOX 9651, FRESNO, CA 93793-9651 LIC. #202026 <input type="checkbox"/> P.O. BOX 1631, RENO, NV 89505 LIC. #10675 <input type="checkbox"/> 3326 A PONDEROSA WAY, LAS VEGAS, NV 89118 LIC. #10675 DATE INSULATION COMPLETED
---	----------	---

PART II AREAS INSULATED

WALLS		CEILING			FLOORS	
(SQUARE FEET)		(SQUARE FEET)			(SQUARE FEET)	
TYPE OF INSULATION		TYPE OF INSULATION			TYPE OF INSULATION	
MATERIAL FIBERGLASS		MATERIAL FIBERGLASS			MATERIAL FIBERGLASS	
FORM BATTS		FORM BATTS & BLOW			FORM BATTS	
MANUFACTURER'S PRODUCT I.D.		MANUFACTURER'S PRODUCT I.D.			MANUFACTURER'S PRODUCT I.D.	
MANUFACTURER		MANUFACTURER			MANUFACTURER	
OCF		OCF			OCF	
BAGS						
R-VALUE INSTALLED	APPLIED THICKNESS	R-VALUE INSTALLED	APPLIED THICKNESS	MIN. INSTALLED WEIGHT PER SQUARE FOOT	R-VALUE INSTALLED	APPLIED THICKNESS
13	3 1/2"	30 30 batt	12" 10"			
KNEE WALLS IF R-VALUE IS OTHER THAN WALLS ABOVE						
MATERIAL FIBERGLASS	FORM BATTS	R-VALUE 13	APPLIED THICKNESS 3 1/2"	MANUFACTURER OCF		
AIR INFILTRATION SEALANT						
MATERIAL FOAM				MANUFACTURER W R GRACE		

THIS IS TO CERTIFY THAT INSULATION AND/OR SEALANT HAS BEEN INSTALLED IN CONFORMANCE WITH APPLICABLE CODES, MATERIAL STANDARDS AND REGULATIONS.

SIGNATURE—INSULATION CONTRACTOR <i>Jeff Cable</i>	TITLE MANAGER	DATE
SIGNATURE—GENERAL CONTRACTOR	TITLE	DATE

REMARKS:

**LANDSCAPING/GRADING
GENERAL RELEASE AND WAIVER
MORRISON HOMES**

Community: BEL LAGO Lot #: 66 Address: 4820 VERENA LANE

City: SACRAMENTO, California. Buyer's Name: FENG

Morrison Homes is the builder of Westlake 6 ^{Village} (Subdivision); and Morrison Homes

(Builder) has requested the SACRAMENTO (City) Building Division to allow

occupancy for the structure in such subdivision referenced above, notwithstanding that

final grading and/or landscaping and/or fencing of the lot has not been performed as

required by the Uniform Building Code; FENG (Buyer) is the prospective

owner of the structure located at 4820 VERENA LANE (Address), permit

number 0197826.

Morrison Homes and Buyer (referenced above) desire to close escrow on the sale of such structure and Buyer desires to occupy such structure as soon as possible but inclement weather has prevented Morrison Homes from completing the final grading on such property; and WHEREAS,

The City of SACRAMENTO Building Division is willing to allow occupancy to

said structure provided that we receive adequate assurance that final grading and/or

landscaping will be completed within (45) FORTY-FIVE DAYS and further provided

that the City of SACRAMENTO is held harmless and indemnified against any

losses or damage due to the failure to complete the final grading and/or landscaping prior

to occupancy of the structure.

In consideration for the occupancy of said structure, Morrison Homes and Buyer do hereby agree for themselves and for their respective heirs, executors, successors and assigns as follows:

1. Morrison Homes will perform all grading and/or landscaping required by the Uniform Building Code on the property referenced above no later than (45) FORTY-FIVE DAYS from the signing of this Waiver and General Release form, weather

Page 2 of 2 - Landscaping/Grading
General Release and Waiver
Morrison Homes

permitting. Upon the satisfactory completion of such grading and/or landscaping,
said contractor must request and receive a grading final and at the time the
SACRAMENTO Building Division will sign the construction hardboard.

- Morrison Homes and Buyer will hold harmless the City of SACRAMENTO
and its members, officers, agents and employees, and shall defend and indemnify
them from and against all claims for loss or damages for bodily injury, personal
injury or property damage (including, without limitation, claims for inverse
condemnation) arising directly or indirectly from the Building Divisions approval of
conditional occupancy as set forth above.
- Morrison Homes and Buyer each hereby releases the City of SACRAMENTO
and its members, officers, agents and employees from any and all liability for losses
damage or injury incurred or sustained by them on account of the Building Division's
approval of a conditional occupancy as set forth above. Such release is given despite
the terms of the California Civil Code, Section 1542 which provides:

"A general release does not extend to claims which the creditor does not know or
suspect to exist in his favor at the time of executing the release, which if known
by him must have materially affected his settlement with the debtor."

Dated: 12/18/01

Morrison Homes Sales Representative Signature

Builder [Signature] Date 12/18/01

Dated: _____
Morrison Homes

By: _____
Sales Manager or President

Dated: 12/18/01

Buyer's Signature [Signature]

Buyer's Signature _____

Print Name Above _____

Builder to check incomplete items as of date of signature.

- Grading
- Landscaping
- Fencing

Signed: _____ Date: _____
Builder

SUNSLATES® Roofing System Acceptance

Project Name: Bel Lago
 Address: 4820 Verena
Sacramento, Ca
 Inverter type: ST1500 Serial# 1819

1. Perform each step as indicated. Mark each step with a checkmark "✓" if satisfactory, an "X" if not satisfactory, or "N/A" if the item is not applicable. Record other information in the space provided for notes.

I. Visual Inspection

A. PV Modules and Module Wiring

Module surface is clean	N/A
No physical damage to array	N/A

B. Source Circuits Splice Junction Boxes

All connectors are secured	N/A
Strain relief is in place at roof penetration	N/A
Hole is sealed with fire stopping foam	N/A
Wiring terminations are tight	✓
Fields wiring is polarity marked	✓
Ground wiring is polarity marked	✓
Labels are in place	✓
Covers are secure	✓

C. Combiner box, DC and AC Disconnected Switches

Wiring terminations are tight	✓
Polarity and magnitude of inputs fields are correct	✓
Correct fuse rating per terminal	✓
Conduit connections are tight	✓
Ground wire is secure	✓
Covers are secure	✓

D. Inverter(s)

Verify field wiring is routed properly	✓
Field wiring terminations are tight	✓
Field wiring is polarity marked	✓
Conduit connections are tight	✓
Ground wire is secure	✓
Main disconnect label is in place	✓
Safety labels are in place	✓

II. Electrical check-out

A. Wires, Cables and Buses

Wire continuity is ok	✓
-----------------------	---

B. Source Circuit Junction Boxes

Polarity and magnitude of inputs are correct	✓
--	---

C. DC Disconnect Switch

Polarity and magnitude of inputs are correct	✓
--	---

D. Inverter(s)

Polarity and magnitude of inputs are correct	✓
--	---

Polarity and magnitude of grid connection is correct	✓
--	---

III. Commissioning

A. System Start Up

Apply AC power to inverter	✓
----------------------------	---

Apply DC power to inverter	✓
----------------------------	---

Confirm system is on-line	✓
---------------------------	---

Confirm operating voltages and power are within expected ranges	✓
---	---

B. Operation

Turn off DC input. Verify that system AC output is zero.	✓
--	---

Restart system	✓
----------------	---

Turn off DC input. Verify that system AC output is zero.	✓
--	---

Restart system	✓
----------------	---

C. Inverter(s) function

Display operates properly	✓
---------------------------	---

Keypad/panel controls operate properly	N/A
--	-----

Over/under voltage (if possible)	
----------------------------------	--

Over/under frequency (if possible)	
------------------------------------	--

Loss of control power (if possible)	✓
-------------------------------------	---

Other functions (as applicable)	
---------------------------------	--

D. PV Meter Installation

Upon completion contact Mike Keesee, Coordinator, SMUD Solar Advantage Home Program, at 732-5244 and call for the installation of a PV Meter

IV. Test Completed by

Name Robert Williams

Robert Williams
Signature

12/18/01
Date

ELECTRICAL SYSTEM PERFORMANCE TEST

Use a standard digital voltmeter to perform these tests. The voltmeter has to be

Test Date	12/18/01	MM/DD/YYYY
Test time	8:45	H:M AM/PM
Sun Irradiation		Watt / m ²
Ambient temp.		°F or °C

AC side:

AC Volts	244	VAC
Breaker size	20	Amps

DC side:

Series Field	Open Circuit Voltage VDC	Short Circuit Current ADC	Notes
1	85.5	.86	
2	84.6	.86	
3	83.9	.84	
4	84.2	.84	
5	84.7	.81	
6	84.7	.81	
7	84.0	.75	
8	84.6	.75	
9	84.8	.70	
10	84.7	.70	
11			
12			
13			
14			
15			
16			
17			
18			
19			
20			

Checked by: *Robert W. Miller*

Date: 12/17/01

SCALE: 1" = 20'

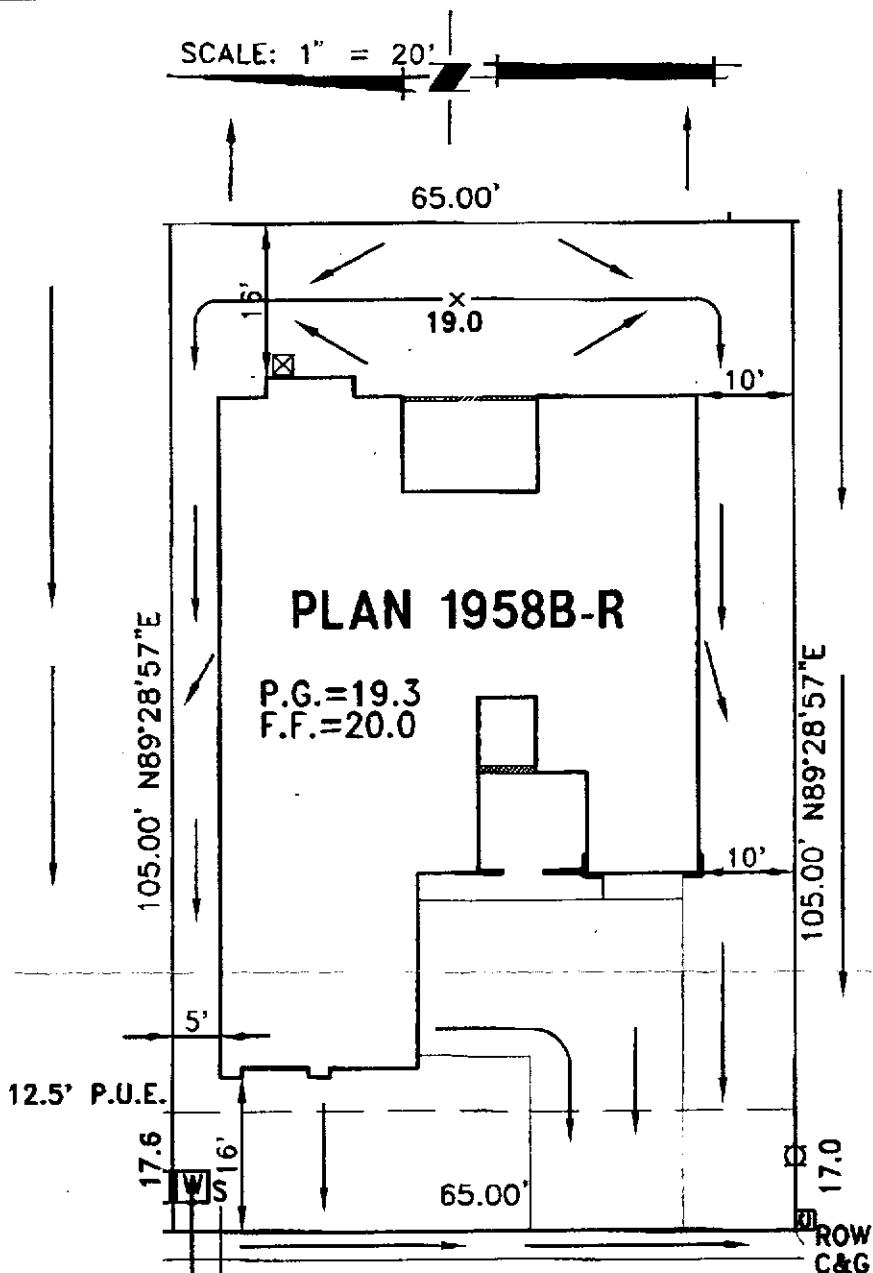

This set of plans and specifications must be kept on the job at all times and it is unlawful to make any changes or alterations from the same without written permission from the Building Inspection Division.
 The approval of this plan and specification shall not be held to permit or excuse the violation of any City Ordinance or State Law.

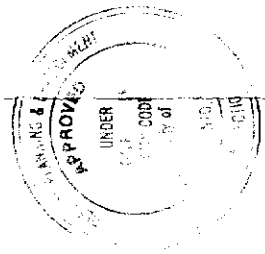

☐ = UTILITY BOX
 ○ = STREET LIGHT

VERENA LANE

LOT COVERAGE: 40.1%
 A.P.N.: 225-1610-066
 ADDRESS: 4820 VERENA LANE

MORRISON HOMES REP.
 OWNER

UNAUTHORIZED CHANGES & USES: THE ENGINEER PREPARING THIS PLOT WILL NOT BE RESPONSIBLE FOR, OR LIABLE FOR, UNAUTHORIZED CHANGES TO OR USES OF THIS PLOT. ALL CHANGES TO THIS PLOT MUST BE IN WRITING AND MUST BE APPROVED BY THE ENGINEER. THE INFORMATION ON THIS PLOT PLAN IS PROVIDED FOR YOUR CONVENIENCE AS A GUIDE TO THE GENERAL LOCATION OF THE SUBJECT PROPERTY. THE ACCURACY OF THIS PLOT PLAN IS NOT GUARANTEED. NOR IS IT A PART OF ANY POLICY, REPORT, OR GUARANTEE TO WHICH IT MAY BE ATTACHED. ACTUAL DIMENSIONS MAY VARY OR CHANGE WITHOUT PRIOR NOTICE DUE TO ACTUAL SITE CONDITIONS.

WOOD RODGERS INC.
 ENGINEERING PLANNING MAPPING SURVEYING
 3301 G STREET, BLDG. 100-B, SACRAMENTO, CA 95816
 PHONE: (916) 341-7760 FAX: (916) 341-7767

WESTBOROUGH VILLAGE 6
 LOT 66
 PLAN 1958B-R
 CITY OF SACRAMENTO, CALIFORNIA
 MAY 2001 DRAWN: HMB CHECKED: [Signature] 1122.028