

CITY OF SACRAMENTO
1231 I Street, Sacramento, CA 95814

Permit No: 0010820

Insp Area: 2

Site Address: 1315 BROADWAY SAC

Parcel No: 009-0253-012

Sub-Type: NOTHR

Housing (Y/N): N

CONTRACTOR

GPS SPECIALTY CONSTRUCTION
203 B KENROY LN
ROSEVILLE CA 95678

OWNER

CA. BANK AND TRUST
1315 BROADWAY
SACRAMENTO CA 95818

ARCHITECT

Nature of Work: EXTERIOR FABRIC AWNING OVER FRONT OF BUILDING.

CONSTRUCTION LENDING AGENCY: I hereby affirm under penalty of perjury that there is a construction lending agency for the performance of the work for which this permit is issued (Sec. 3097, Civ. C).

Lender's Name _____ Lender's Address _____

LICENSED CONTRACTORS DECLARATION: I hereby affirm under penalty of perjury that I am licensed under provisions of Chapter 9 (commencing with section 7000) of Division 3 of the Business and Professions Code and my license is in full force and effect.

X License Class CC-1 License Number 73185 Date 9/18/2000 Contractor Signature [Signature]

OWNER-BUILDER DECLARATION: I hereby affirm under penalty of perjury that I am exempt from the contractors License Law for the following reason (Sec. 7031.5, Business and Professions Code: any city or county which requires a permit to construct, alter, improve, demolish, or repair any structure, prior to its issuance, also requires the applicant for such permit to file a signed statement that he or she is licensed pursuant to the provisions of the Contractors License Law (Chapter 9 (commencing with Section 7000) of Division 8 of the Business and Professions Code) or that he or she is exempt therefrom and the basis for the alleged exemption. Any violation of Section 7031.5 by any applicant for a permit subjects the applicant to a civil penalty of not more than five hundred dollars (\$500.00);

____ I, as a owner of the property, or my employees with wages as their sole compensation, will do the work, and the structure is not intended or offered for sale (Sec. 7044, Business and Professional Code: The Contractors License Law does not apply to an owner of property who builds or improves thereon, and who does such work himself or herself or through his/her own employees, provided that such improvements are not intended or offered for sale. If, however, the building or improvement is sold within one year of completion, the owner-builder will have the burden of proving that he/she did not build or improve for the purpose of sale.)

____ I, as owner of the property, am exclusively contracting with licensed contractors to construct the project (Sec. 7044, Business and Professions Code: The Contractors License Law does not apply to an owner of property who builds or improves thereon, and who contracts for such projects with a contractor(s) licensed pursuant to the Contractors License Law).

____ I am exempt under Sec. _____ B & PC for this reason: _____

Date _____ Owner Signature _____

IN ISSUING THIS BUILDING PERMIT, the applicant represents, and the city relies on the representation of the applicant, that the applicant verified all measurements and locations shown on the application or accompanying drawings and that the improvement to be constructed does not violate any law or private agreement relating to permissible or prohibited locations for such improvements. This building permit does not authorize any illegal location of any improvement or the violation of any private agreement relating to location of improvements.

I certify that I have read this application and state that all information is correct. I agree to comply with all city and county ordinances and state laws relating to building construction and hereby authorize representative(s) of this city to enter upon the abovementioned property for inspection purposes.

X Date 9/18/2000 X Applicant/Agent Signature [Signature]

WORKER'S COMPENSATION DECLARATION: I hereby affirm under penalty of perjury one of the following declarations:

____ I have and will maintain a certificate of consent to self-insure for workers' compensation as provided for by Section 3700 of the Labor Code, for the performance of work for which the permit is issued.

X I have and will maintain workers' compensation insurance, as required by Section 3700 of the Labor Code, for the performance of the work for which this permit is issued. My workers' compensation insurance carrier and policy number are:

Carrier STATE FUND Policy Number 692228499 Exp Date 10/01/2000

____ (This section need not be completed if the permit is for \$100 or less) I certify that in the performance of the work for which this permit is issued, I shall not employ any person in any manner so as to become subject to the workers' compensation laws of California and agree that if I should become subject to the workers' compensation provisions of Section 3700 of the Labor Code, I shall forthwith comply with those provisions.

X Date 9/18/2000 X Applicant Signature [Signature]

WARNING: FAILURE TO SECURE WORKER'S COMPENSATION COVERAGE IS UNLAWFUL AND SHALL SUBJECT AN EMPLOYER TO CRIMINAL PENALTIES AND CIVIL FINES UP TO ONE HUNDRED THOUSAND DOLLARS (\$100,000) IN ADDITION TO THE COST OF COMPENSATION, DAMAGES AS PROVIDED FOR IN SECTION 3706 OF THE LABOR CODE, INTEREST AND ATTORNEY'S FEE.

THIS PERMIT SHALL EXPIRE BY LIMITATION IF WORK IS NOT COMMENCED WITHIN 180 DAYS.

**CITY OF SACRAMENTO
DEVELOPMENT SERVICES DIVISION**

EXPRESS PLAN REVIEW

SUBMITTALS					
1st Review		2nd Review		3rd Review	
IN	OUT	IN	OUT	IN	OUT
/ /	/ /	/ /	/ /	/ /	/ /

PROJECT NO. _____
 PROJECT NAME _____
 ADDRESS _____
 CITY _____



DATE OF REVIEW _____
 REVIEWER _____

REVIEW TYPE	1st Review			2nd Review			DATE	REVIEWER
	NO.	INITIALS	DATE	NO.	INITIALS	DATE		
PRELIMINARY	13	JT	9/15					
FINAL	3	JT	"	13	JT	9/18		
OTHER								
TOTAL	13	BJF	9/15					

STAFF COMMENTS: _____

APPLICATION FOR COMMERCIAL BUILDING PERMIT

CITY OF SACRAMENTO
DEVELOPMENT SERVICES DIVISION
PERMIT SERVICES SECTION

1231 I Street, Rm. 200
 Sacramento, CA 95814 (916) 264-7619 FAX 264-7046

ACTIVITY #

0010820

Insp. Area

[Handwritten Signature]

Applicant **MUST** complete ALL Unshaded areas

ADDRESS 1315 BROADWAY Suite _____

PARCEL # 09-0793-01

<p style="text-align: center;">CONTACT</p> <p>Name <u>MICHAEL GILWIM</u></p> <p>Street Address _____</p> <p>City/State/Zip _____</p> <p>Phone _____ FAX _____</p> <p>E-mail: _____</p>	<p style="text-align: center;">LICENSED CONTRACTOR Lic No. # <u>731185</u></p> <p>Name <u>GPS SPECIALTY CONST., INC.</u></p> <p>Address <u>203 B KENROY LANE</u></p> <p>City/State/Zip <u>ROSEVILLE / CA / 95678</u></p> <p>Phone <u>(916) 786-3330</u> FAX <u>(916) 786-0504</u></p> <p>E-mail: <u>AWNINGS@QUIKNET.COM</u></p>
<p style="text-align: center;">ARCHITECT/ENGINEER</p> <p>Name <u>ERIC REITZEL</u></p> <p>Address <u>5029 BURNBRAE PLACE</u></p> <p>City/State/Zip <u>ANTELOPE / CA / 95843</u></p> <p>Phone _____ FAX _____</p> <p>E-mail: _____</p>	<p style="text-align: center;">OWNER</p> <p>Name <u>CALIFORNIA BANK & TRUST</u></p> <p>Address <u>1315 BROADWAY</u></p> <p>City/State/Zip <u>SACRAMENTO / CA.</u></p> <p>Phone _____ FAX _____</p> <p>E-mail: _____</p>

→ Will permittee have any employees on the jobsite? No Yes → INSURANCE CO: _____

→ WORKER'S COMPENSATION POLICY # 692228499 EXPIRATION DATE: 10/01/00

NATURE OF WORK IN DETAIL: EXTERIOR FABRIC AWNING OVER FRONT OF BUILDING

OCCUPANT/TENANT: CALIFORNIA BANK & TRUST VALUATION: \$ 4,900.00

FLOOD STATUS:			S.C.A.T.							
JOB DESCRIPTION		BLDG	SHELL	APT	TI()	REM()	SW	FIRE	ADD	<u>OTH</u>
INSPECTION DISCIPLINES			<u>BLDG</u>	MECH	PLUMB	ELEC	SITE	<u>FIRE</u>		
# Stories	1st flrArea.	Total Area	Use Zone	Occp Group	Const type	Fire Req. <u>Y/N</u>		Fed Code	Vio. File	
				<u>B</u>	<u>/</u>	SPR	ALARM	<u>15</u>	[H]	[Quad]
B	L	P	M	E	F	S		D	PW	UTIL
					<u>13 SF</u>			<u>VA</u>		

COMMENTS: _____

REGIONAL SANITATION FEES? Yes No HEALTH DEPARTMENT? Yes No

WATER FLOW TEST FOR NEW BUILDINGS OR ADDITIONS? Provided Faxed

**CITY OF SACRAMENTO
DESIGN REVIEW**

PROJECT NO. Over the gateway
 APPROVED BY: *Charles DeHaven*
 APPROVAL DATE: 9-13-00

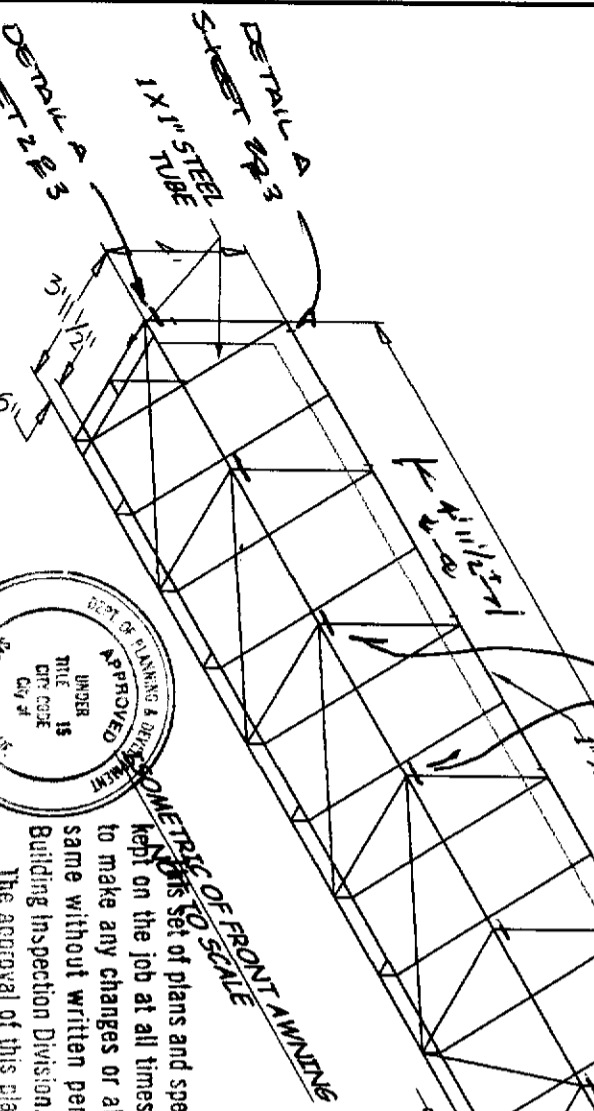
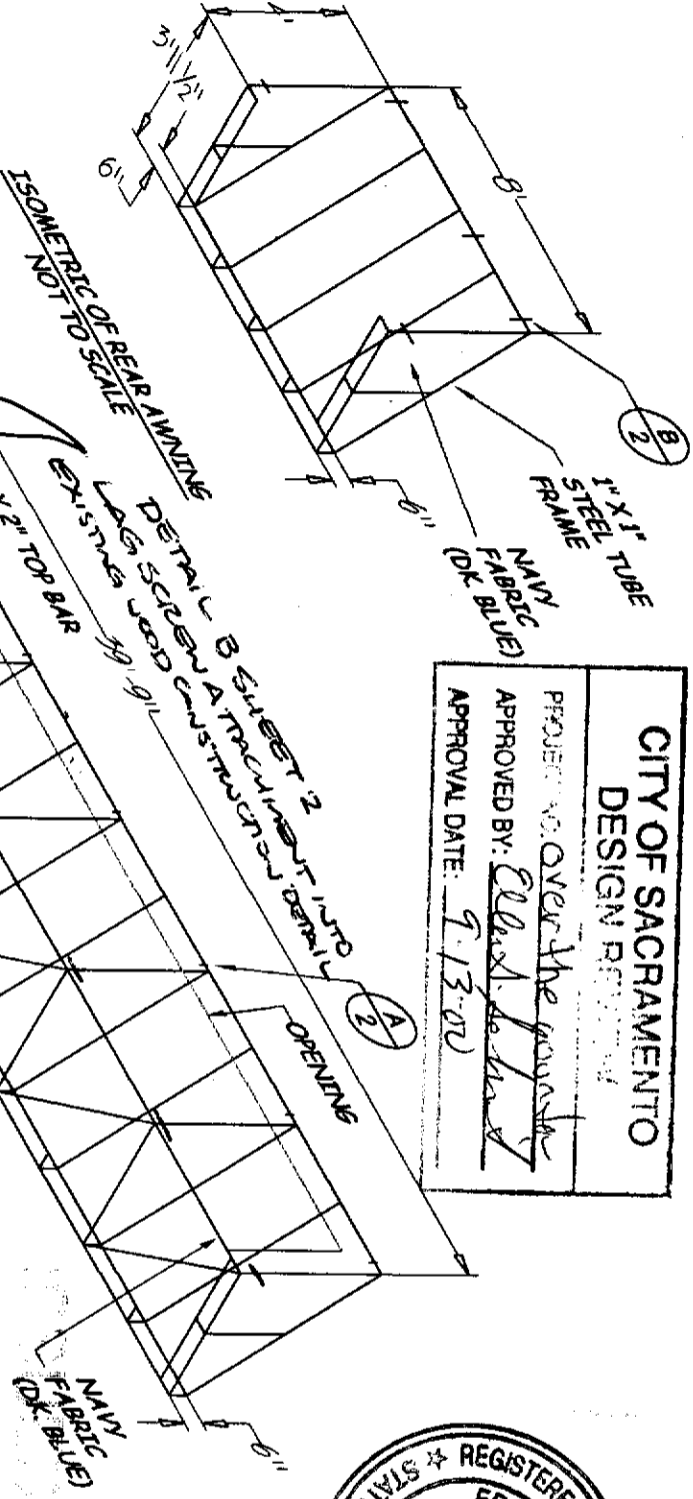

SPECIFICATION SCHEDULE

- 1) FRAMEWORK TO BE 085 X 1" ROUND & SQUARE TUBULAR STEEL THROUGHOUT UNLESS NOTED OTHERWISE
- 2) FRAMEWORK TO BE ALL WELDED CONSTRUCTION WITH CONTINUOUS 1/8 - 3/16" FILET WELDS THROUGHOUT. ALL WELDS TO BE GROUND AND/OR SANDED SMOOTH WHERE CONTACT WITH FABRIC OCCURS
- 3) ALL STEEL FRAMEWORK, Z-CLIPS AND ALUMINUM WALL RAIL TO BE POWDER COATED. COLOR TO BE DETERMINED BY ARCHITECT
- 4) FABRIC:
 - A) MANUFACTURE: FIRE RESIST BY GLEN RAVEN MILLS INC.
 - B) COLOR: #8648 NAVY
 - C) STATE OF CALIFORNIA STATE FIRE MARSHAL REGISTERED THREAD: M1000 & M1000H BLACK TENARA (GORETEX) TO CLOSELY MATCH FABRIC

Set of plans and specifications must be kept on the job at all times and it is the responsibility of the contractor to make any changes or alterations from the original drawings. A) FRAMEWORK TO BUILDING: PER ENGINEERS SPECIFICATIONS TO BUILDING. B) COVER TO FRAMEWORK: PER ENGINEERS SPECIFICATIONS TO BUILDING. C) SEW 1/4 POLYESTER ROPE INTO 1" FLAT ROPE HEM ALONG TOP OF COVER. SLIDE INTO ALUMINUM WALL EXTRUSION. D) ENDS @ BACK: SEW 1" TEK TABS TO BACK OF COVER. E) WRAP AROUND TO INSIDE OF FRAMEWORK AND FASTEN WITH 1/8" X 1/2" TEK SCREWS 6" +/- O.C. TO ACHIEVE TAUNT FIT. F) FRONT & ENDS @ BOTTOM: USE 1/8" BLACK POLYPROPYLENE LACE BORD THROUGH #1 NICKEL RR SPUR GROMMETS 6" +/- O.C. AROUND LACE BAR TO ACHIEVE TAUNT FIT. G) USE CLEAR CONSTRUCTION GRADE SILICONE CAULK ALONG JOINT BETWEEN ALUMINUM WALL RAIL AND EXTERIOR SURFACE OF WINDOW MULLIONS TO ENSURE WEATHER TIGHT SEAL.

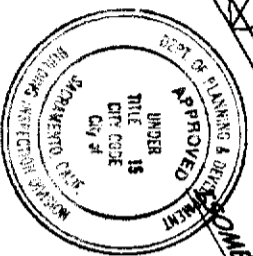

REVISIONS	BY
REVISED 7-5-2000	DA
FRAMEWORK	

CALIFORNIA BANK & TRUST
 ANNEX BUILDING
 12 TH & BROADWAY
 SACRAMENTO

GPS SPECIALTY CONSTRUCTION INC.
 203 B Kenny Lane, Roseville, CA 95707
 Telephone: 916-786-3330 FAX: 916-786-3334
 Contractor License #31385
 H & D - 03

GPS SPECIALTY CONSTRUCTION INC. does not represent that these plans or the specifications in connection therewith are suitable, whether or not modified for any other site than the one they were prepared. GPS SPECIALTY CONSTRUCTION INC. disclaims responsibility for these plans and specifications if they were used in whole or in part at any other site. All drawings and written material appearing herein constitute the original and unpublished work of GPS SPECIALTY CONSTRUCTION INC. and the same may not be duplicated, used, or disclosed without written consent of GPS SPECIALTY CONSTRUCTION INC.

DATE: 02-15-2000

SCALE: NOTED

DRAWN: DA

JOB: NOTED

SHEET: ONE

OF THREE SHEETS

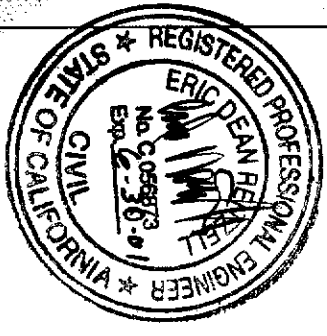
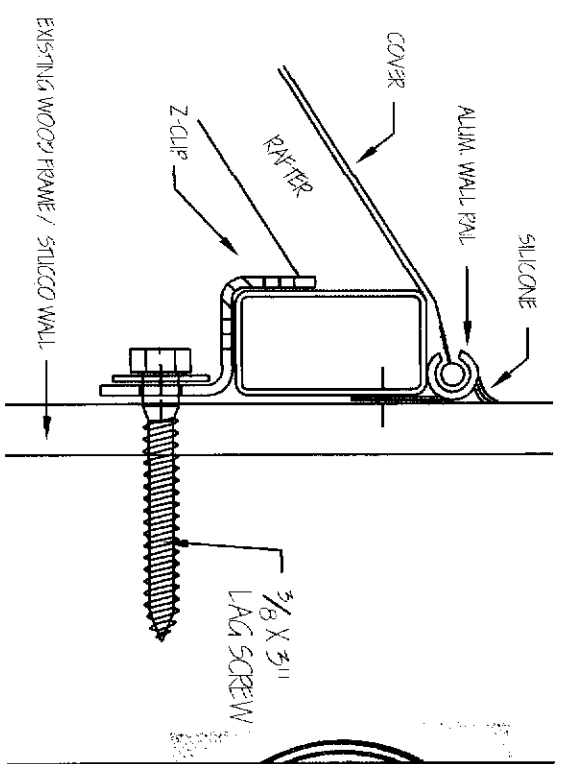
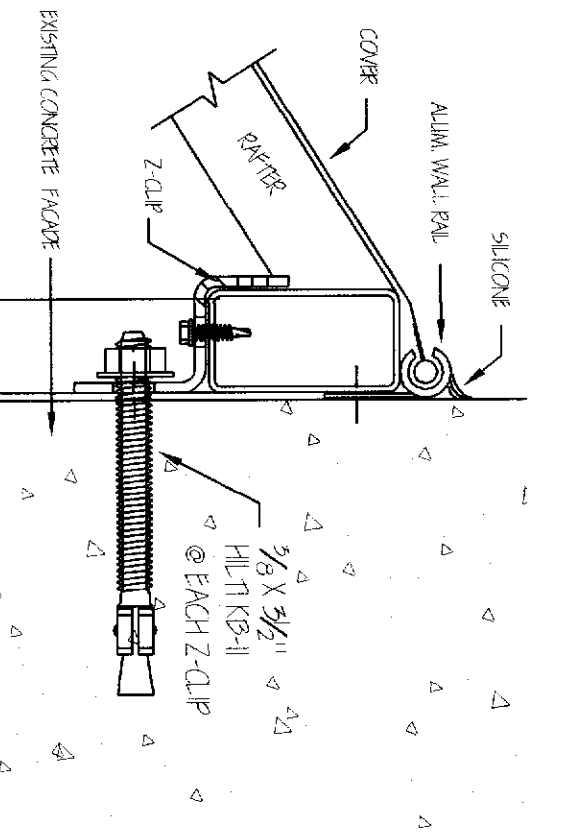

A Z-CLIP ATTACHMENT DETAIL
SCALE: 6" = 1'-0"

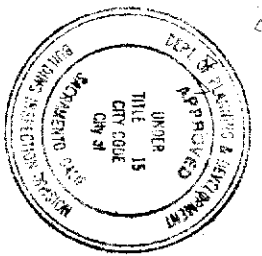

This set of plans and specifications must be kept on the job at all times and it is unlawful to make any changes or alterations from the same without written permission from the Building Inspection Division. The approval of this plan and specification SHALL NOT be held to permit or approve the violation of any City Ordinance or State Law.

B Z-CLIP ATTACHMENT DETAIL
SCALE: 6" = 1'-0"

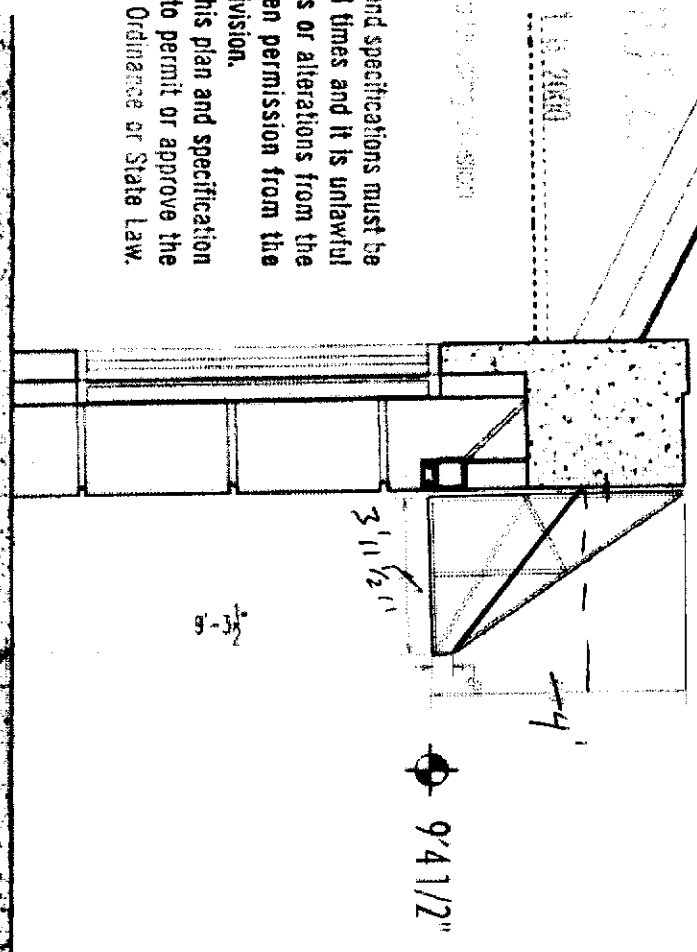

REVISIONS	BY

12 TH & BROADWAY
SACRAMENTO

GPS SPECIALTY CONSTRUCTION INC.
2015 B Kennedy Lane, Roseville, CA 95678
Telephone: 916-785-3331 FAX: 916-786-0005
Construction License # 71151
E.S.D. - 03

GPS SPECIALTY CONSTRUCTION INC. does not represent that these plans or the specifications in connection therewith are suitable, whether or not modified for any other site than the one they were prepared. GPS SPECIALTY CONSTRUCTION INC. disclaims responsibility for these plans and specification if they were used in whole or in part at any other site. All drawings and written material appearing herein constitute the original and unaltered work of GPS SPECIALTY CONSTRUCTION INC. and the same may not be duplicated, used, or disclosed with out written consent of GPS SPECIALTY CONSTRUCTION INC.

DATE: 02-15-2000

SCALE: NOTED

DRAWN: DA

JOB: NOTED

SHEET:

TWO

OF THREE SHEETS

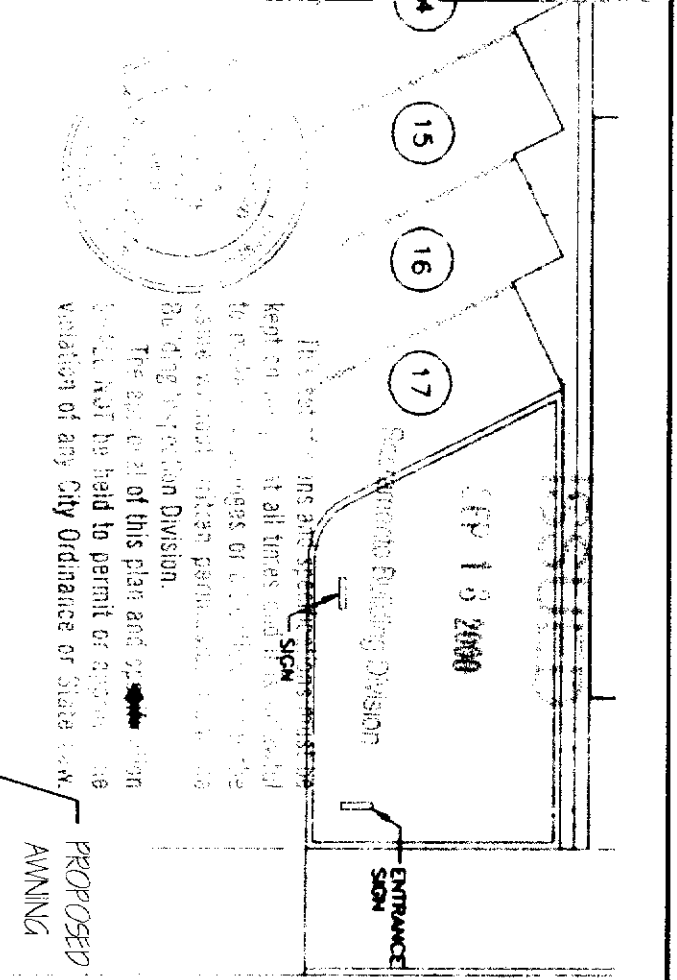
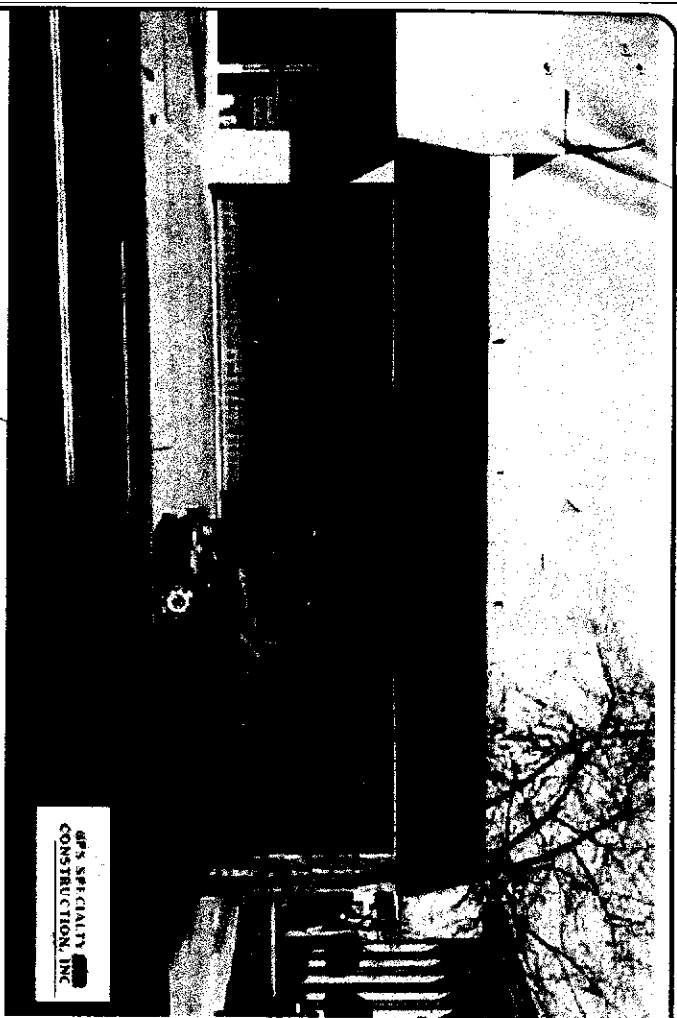

This set of plans are special permits kept on file at all times and are subject to modification or changes of any kind by the Sacramento Building Division. The approval of this plan and special permit shall be held to permit of approval, the violation of any City Ordinance or State Law.

BROADWAY

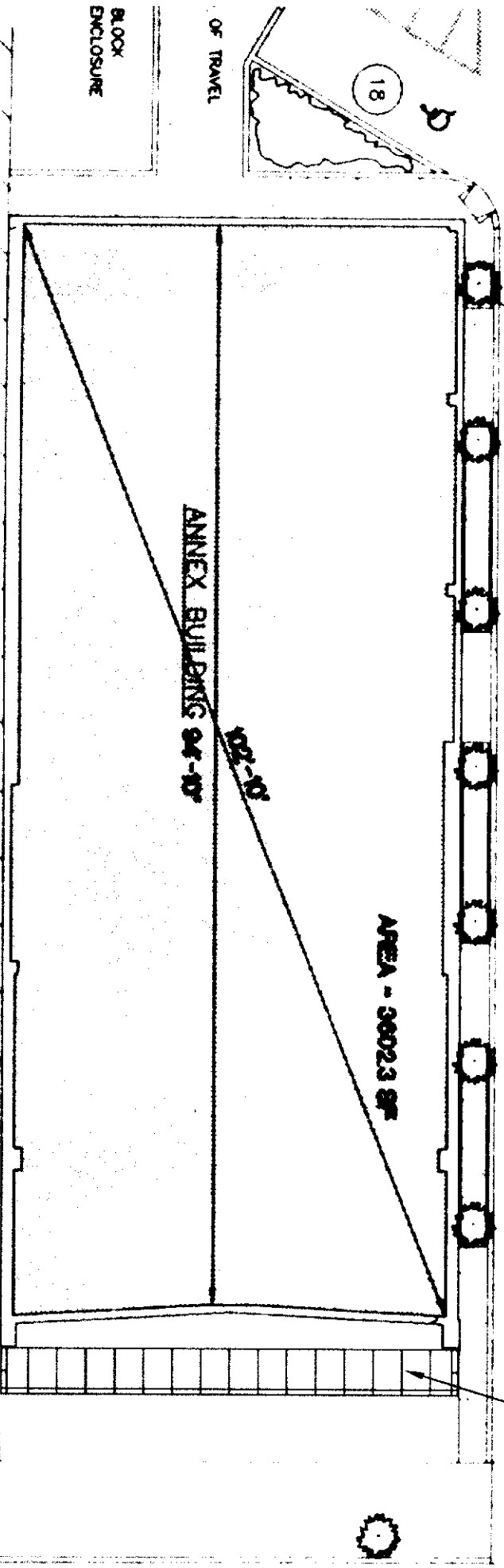

OF TRAVEL
BLOCK
ENCLOSURE

CALIFORNIA BANK & TRUST
ANNEX BUILDING
12 TH & BROADWAY
SACRAMENTO

REVISIONS	BY

GPS SPECIALTY CONSTRUCTION, INC.
2418 E. Energy Lane, Roseville, CA 95678
Telephone: 916-786-0334 FAX: 916-786-0334
Contractor License: 714845
E. S. D. 415

GPS SPECIALTY CONSTRUCTION, INC. does not represent that these plans or the specifications in connection therewith are suitable, whether or not modified for any other site than the one they were prepared. GPS SPECIALTY CONSTRUCTION, INC. disclaims responsibility for these plans and specification if they were used in whole or in part at any other site. All drawings and written material appearing herein constitute the original and unpublished work of GPS SPECIALTY CONSTRUCTION, INC. and the same may not be duplicated, used, or disclosed with out written consent of GPS SPECIALTY CONSTRUCTION, INC.

DATE: 02-15-2000
SCALE: NOTED
DRAWN: DA.
JOB: NOTED

SHEET:
THREE
OF THREE SHEETS

Structural Calculations
For
12th and Broadway - Awning
Sacramento, CA

Eric Reitzell
Professional Engineer
Structural Design
5029 Burnbrae Place
Antelope, CA 95843
7/11/00

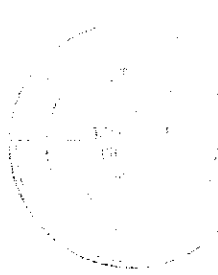

ISSUED

SEP 18 2000

Professional Engineer

ER

7.11.00

12th & BROADWAY

AWNING

LOADS

DL = 2 psf

LL = 10 psf

Wind: 75 mph EXP B

SEISMIC: 92 UBC - negligible compared to wind.

wind pressure

$$P = 0.62(1.7)(14.5)(1.0) = 15.3 \text{ psf upward}$$

$$= 0.62(1.3)(14.5)(1.0) = 11.7 \text{ psf lateral}$$

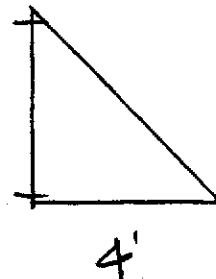
Connection

$$T/\text{bolt}: 15.3(6)(4)^2/2 \div 4 = 184\#$$

$$V/\text{bolt}: (15.3)(6)(4)/2 = 184\#$$

Concrete wall

$$\frac{184}{930} + \frac{184}{1330} = .34 < 1.0 \text{ OK}$$

use $3/8" \phi \times 2 1/2"$ embed
bolt. $K = 11$ in
concrete wallWood wall

$$\frac{184}{305(2)(1.33)} + \frac{184}{250(1.33)} = .73 < 1.0 \text{ OK}$$

use $3/8" \phi \times 2"$ lag
in wood wall

(withdrawal) 390 (shear // to grain)