

**CITY OF SACRAMENTO**  
1231 I Street, Sacramento, CA 95814

**Permit No: 0204195**

**Insp Area: 4**

Thos Bros:

Sub-Type: NSFR

Housing (Y/N): N

**Site Address: 3259 SPINNING ROD WY SAC**

Parcel No: 274-0590-050

RIVERWALK II LOT98

CONTRACTOR

MYERS HOMES INC.  
3300 FITZGERALD RD.  
RANCHO CORDOVA CA. 95742

OWNER

ARCHITECT

**Nature of Work: NSFR MP2655 2 STORY 9 RMS**

**CONSTRUCTION LENDING AGENCY :** I hereby affirm under penalty of perjury that there is a construction lending agency for the performance of the work for which this permit is issued (Sec. 3097, Civ. C).

Lender's Name \_\_\_\_\_ Lender's Address \_\_\_\_\_

**LICENSED CONTRACTORS DECLARATION:** I hereby affirm under penalty of perjury that I am licensed under provisions of Chapter 9 (commencing with section 7000) of Division 3 of the Business and Professions Code and my license is in full force and effect.

License Class B License Number 744473 Date 4/9/02 Contractor Signature [Signature]

**OWNER-BUILDER DECLARATION:** I hereby affirm under penalty of perjury that I am exempt from the contractors License Law for the following reason (Sec. 7031.5, Business and Professions Code; any city or county which requires a permit to construct, alter, improve, demolish, or repair any structure, prior to its issuance, also requires the applicant for such permit to file a signed statement that he or she is licensed pursuant to the provisions of the Contractors License Law (Chapter 9 (commencing with Section 7000) of Division 8 of the Business and Professions Code) or that he or she is exempt therefrom and the basis for the alleged exemption. Any violation of Section 7031.5 by any applicant for a permit subjects the applicant to a civil penalty of not more than five hundred dollars (\$500.00);

\_\_\_\_ I, as a owner of the property, or my employees with wages as their sole compensation, will do the work, and the structure is not intended or offered for sale (Sec. 7044, Business and Professional Code: The Contractors License Law does not apply to an owner of property who builds or improves thereon, and who does such work himself or herself or through his/her own employees, provided that such improvements are not intended or offered for sale. If, however, the building or improvement is sold within one year of completion, the owner-builder will have the burden of proving that he/she did not build or improve for the purpose of sale.)

\_\_\_\_ I, as owner of the property, am exclusively contracting with licensed contractors to construct the project. (Sec. 7044, Business and Professions Code: The Contractors License Law does not apply to an owner of property who builds or improves thereon, and who contracts for such projects with a contractor(s) licensed pursuant to the Contractors License Law).

**PAID**

**CITY OF SACRAMENTO**

APR 09 2002

\_\_\_\_ I am exempt under Sec. \_\_\_\_\_ B & PC for this reason: \_\_\_\_\_

Date \_\_\_\_\_ Owner Signature \_\_\_\_\_

**NORTH PERMIT CENTER**

**IN ISSUING THIS BUILDING PERMIT,** the applicant represents, and the city relies on the representation of the applicant, that the applicant verified all measurements and locations shown on the application or accompanying drawings and that the improvement to be constructed does not violate any law or private agreement relating to permissible or prohibited locations for such improvements. This building permit does not authorize any illegal location of any improvement or the violation of any private agreement relating to location of improvements.

I certify that I have read this application and state that all information is correct. I agree to comply with all city and county ordinances and state laws relating to building construction and hereby authorize representative(s) of this city to enter upon the abovementioned property for inspection purposes.

Date 4/9/02 Applicant/Agent Signature [Signature]

**WORKER'S COMPENSATION DECLARATION:** I hereby affirm under penalty of perjury one of the following declarations:

\_\_\_\_ I have and will maintain a certificate of consent to self-insure for workers' compensation as provided for by Section 3700 of the Labor Code, for the performance of work for which the permit is issued.

[Signature] I have and will maintain workers' compensation insurance, as required by Section 3700 of the Labor Code, for the performance of the work for which this permit is issued. My workers' compensation insurance carrier and policy number are:

Carrier **RELIANCE NAT INS CO**

Policy Number **NWAO154613-01**

Exp Date **04/01/2002**

\_\_\_\_ (This section need not be completed if the permit is for \$100 or less) I certify that in the performance of the work for which this permit is issued, I shall not employ any person in any manner so as to become subject to the workers' compensation laws of California and agree that if I should become subject to the workers' compensation provisions of Section 3700 of the Labor Code, I shall forthwith comply with those provisions.

Date 4/9/02 Applicant Signature [Signature]

**WARNING: FAILURE TO SECURE WORKER'S COMPENSATION COVERAGE IS UNLAWFUL AND SHALL SUBJECT AN EMPLOYER TO CRIMINAL PENALTIES AND CIVIL FINES UP TO ONE HUNDRED THOUSAND DOLLARS (\$100,000) IN ADDITION TO THE COST OF COMPENSATION, DAMAGES AS PROVIDED FOR IN SECTION 3706 OF THE LABOR CODE, INTEREST AND ATTORNEY'S FEE.**

**THIS PERMIT SHALL EXPIRE BY LIMITATION IF WORK IS NOT COMMENCED WITHIN 180 DAYS.**

### RESIDENTIAL BUILDING PERMIT APPLICATION

- New Construction
- Addition
- Remodels
- Other

Project Address: 3259 Spinning Rod Way Assessor Parcel # 274-059-050

#### OWNER INFORMATION:

Legal Property Owner: MYERS HOMES OF CALIFORNIA, LLC Phone # 916-851-0530  
 Owner Address: 3480 Sunrise Blvd, #200 City RANCHO CORONA State CA Zip 92742

#### CONTRACTOR INFORMATION:

Contractor: MYERS HOMES, INC. Lic. # 744473 Phone # 916-851-0530 Fax # 916-851-0535

#### PROJECT INFORMATION:

Land Use Zone R-1A PUD Occupancy Group R-3 Construction Type VN - Fed Code 1A  
 No. of stories: 2 No. of rooms: 13 Street width: 50 FT  
 1<sup>st</sup> Floor Area 1611 2<sup>nd</sup> Floor Area 1044 Basement N/A Roof Material TILE

AREA IN SQUARE FOOT OF:	EXISTING	NEW
Dwelling/Living	_____	<u>2655</u>
Garage/Storage	_____	<u>6600</u>
Decks/Balconies	_____	<u>118 COVERED FRONT PORCH</u>
Carpors	_____	_____

SCOPE OF WORK: NEW CONSTRUCTION OF SINGLE FAMILY RESIDENCE ; RIVERWALK SERIES II, PLAN 6/2655 IN MASTER PLAN COMMUNITY P99-075  
P97-005 AMENDED

#### FOR OFFICE USE ONLY:

- Information above complete
- Violation files checked
- Standard setbacks
- County Sewer
- AR Flood Waiver required
- Flood Elevation Certificate Required
- Water Development Infill Area
- Planning Approval
- Design Review Approval
- Special Fee Districts Apply

#### NEW STRUCTURES & ADDITIONS

THE FOLLOWING MUST BE PROVIDED IN ORDER TO SUBMIT FOR PLAN REVIEW

- 2 COMPLETE PLANS, LEGIBLE & DRAWN TO SCALE <sup>PLAT 8.5" x 11"</sup> <sup>DRAINAGE INFO</sup>
  - 3 SETS IF PROJECT IS IN A DESIGN REVIEW AREA
  - Title 24 Energy Compliance documentation
  - Grading and Erosion Control Questionnaire
  - 11" x 17" copy of floor plan for County Assessor
  - Plan Review Fees
- Plans to include: site plan, floor plan, elevations, roof/ceiling plan, foundation and structural framing details, and structural calculations for non-conforming structures.

Date: \_\_\_\_\_ Received by: (staff) \_\_\_\_\_

ACTIVITY/PERMIT # \_\_\_\_\_

LOT 98

# OMEGA PRODUCTS CORP.

## DIAMOND WALL INSULATING STUCCO SYSTEM

JOB ADDRESS:

3259 Spinning Rod Way

ICNO Report #4004

Date of Job Completion 7/22/02

PLASTERING CONTRACTOR:

Name: Norcal Plastering

Address: Box 355 Lincoln Ca 95648

Telephone No: (716) 645-7337

Contractor Number of Diamond Wall System 2130

This is to certify that the exterior coating system on the building exterior at the above address has been installed in accordance with the evaluation report specified above and the manufacturer's instructions.

Date \_\_\_\_\_

Jim Swerton  
Signature of authorized representative of  
Plastering Contractor

This installation card must be presented to the building inspector after completion of work and before final inspection.

COUNTY SANITATION DISTRICT NO. 1  
 SACRAMENTO REGIONAL COUNTY SANITATION DISTRICT  
**SEWER IMPACT FEE**  
 PERMIT AND CALCULATION SHEET

APPLICATION NO.:

BLDG PERMIT NO: City

GENERAL INFORMATION

THIS PERMIT GOOD ONLY WHEN  
 VALIDATED BY THE CASHIER

SWD 2001-00293

4/19/02 AJ

THIS PERMIT TO CONNECT EXPIRES  
 ONE YEAR FROM DATE OF ISSUANCE

FEE CALCULATION

BUILDING USE

INSPECTION	RESIDENTIAL	SF	MF	UNITS
CSD-1		<u>473</u>	<input checked="" type="checkbox"/>	
SRCSD		<u>2400</u>		
CONSTRUCTION				
IN-LIEU				
<b>TOTAL FEE</b>		<u>28720</u>		

APN: 274-0030-077

DESCRIPTION/  
 SUBDIVISION Riverwalk

LOT: 98

PROPERTY ADDRESS 3259 Spinning Road WY

OWNER Myers Homes of Calif LLC

MAILING ADDRESS 3480 Sunrise Blvd, Ste 200

CITY-STATE-ZIP Rancho Cordova CA 95742 PHONE 916 851-0530

ADDITIONAL FEES MAY BE DUE IF CHANGES IN USE INCREASE SEWER IMPACT.

APPLICANT SIGNATURE

*Monica Rose*

CONSOLIDATED UTILITY BILLING USE ONLY

ACCT \_\_\_\_\_

INPUT \_\_\_\_\_

START \_\_\_\_\_

# CERTIFICATION OF INSULATION

ADDRESS OR TRACT

SACRAMENTO BUILDING PRODUCTS

**MEYERS**

LOT # **98**

- P.O. BOX 854, WEST SACRAMENTO, CA 95691 LIC. #202026
- 1309 MELODY ROAD, MARYSVILLE, CA 95901 LIC. #202026
- P.O. BOX 9651, FRESNO, CA 93793-9651 LIC. #202026
- P.O. BOX 1631, RENO, NV 89505 LIC. #10675
- 3326 A PONDEROSA WAY, LAS VEGAS, NV 89118 LIC. #10675

**RIVER WALK**

DATE INSULATION COMPLETED

**7-10-02**

WALLS

CEILING

FLOORS

( SQUARE FEET)			( SQUARE FEET)			( SQUARE FEET)		
TYPE OF INSULATION			TYPE OF INSULATION			TYPE OF INSULATION		
MATERIAL <b>FIBERGLASS</b>			MATERIAL <b>FIBERGLASS</b>			MATERIAL <b>FIBERGLASS</b>		
FORM <b>BATTS</b>			FORM <b>BATTS &amp; BLOW</b>			FORM <b>BATTS</b>		
MANUFACTURER'S PRODUCT I.D.			MANUFACTURER'S PRODUCT I.D.			MANUFACTURER'S PRODUCT I.D.		
MANUFACTURER			MANUFACTURER			MANUFACTURER		
CT	OC	JM	CT	OC	JM	CT	OC	JM
			BAGS					
R-VALUE INSTALLED	APPLIED THICKNESS	R-VALUE INSTALLED	APPLIED THICKNESS	R-VALUE INSTALLED	APPLIED THICKNESS	R-VALUE INSTALLED	APPLIED THICKNESS	R-VALUE INSTALLED
<b>13</b>	<b>3 5/8</b>	<b>30</b> <b>30</b>	<b>9</b> <b>12</b>					

KNEE WALLS IF R-VALUE IS OTHER THAN WALLS ABOVE

MATERIAL	FORM	R VALUE	MANUFACTURER		
<b>FIBERGLASS</b>	<b>BATTS</b>		CT	OC	JM

AIR INFILTRATION SEALANT

MATERIAL	MANUFACTURER	
<b>FOAM</b>	<b>HILTI</b>	<b>HANDY FOAM</b>

THIS IS TO CERTIFY THAT INSULATION AND/OR SEALANT IS INSTALLED IN ACCORDANCE WITH APPLICABLE CODES, MATERIAL STANDARDS AND REGULATIONS.

SIGNATURE — INSULATION CONTRACTOR <i>Jeff Cable</i>	TITLE <b>MANAGER</b>	DATE <b>7-15-02</b>
SIGNATURE — GENERAL CONTRACTOR	TITLE	DATE

REMARKS

PART I GENERAL  
PART II AREAS INSULATED  
PART III CERTIFICATION

**Natomas Unified School District**  
 1515 Sports Drive, #1 • Sacramento, CA 95834-1905  
 Phone 916/641-3300 • Fax 916/928-1629

**CERTIFICATION OF COMPLIANCE**  
**SCHOOL DISTRICT DEVELOPMENT FEES**

<b>PART I: TO BE COMPLETED BY APPLICANT</b>			
Property Owner's Name			
Owner's Address			
Project Address <i>3957 Spring Hill Way</i>			
Parcel Number <i>24-157-020</i>			
Subdivision Name			
Number of Units <i>1</i>			
Print Applicant's Name		Applicant's Signature <i>[Signature]</i>	
Title of Applicant			
Date		Telephone Number	
<b>PART II: TO BE COMPLETED BY BUILDING DEPARTMENT</b>			
Plan Identification Number <i>2650</i>			
Building Type (Check One)			
<input checked="" type="checkbox"/> Residential	<input type="checkbox"/> Apartment/Condominium		<input type="checkbox"/> Commercial/Industrial
Square Feet of Chargeable Building Area			
Signature <i>[Signature]</i>			
Title <i>BLDG TECH</i>		Date <i>11/2/01</i>	
<b>PART III: TO BE COMPLETED BY NATOMAS UNIFIED SCHOOL DISTRICT</b>			
District Certification Number <i>02-212</i>			
Fees Collected:			
Residential: <i>500</i>	Sq. Ft. X \$	= \$	<i>2874.25</i>
Apartment/Condominium:	Sq. Ft. X \$	= \$	
Commercial/Industrial:	Sq. Ft. X \$	= \$	
<p><b>NOTICE TO APPLICANT:</b> Pursuant to government code section 66020 (d), this will serve to notify you that the 90-day approval period in which you may protest the fees, or other payment identified above, will begin to run on the date in which the building or installation permit for this project is issued, or on which they are paid to the District, or to another public entity authorized to collect them on behalf of the District, whichever is earlier.</p>			
Applicant Signature: _____		Date: _____	

This certification covers only the amount of square footage indicated above. Any additions or corrections to the square footage for this project will require an amendment to the Certificate of Compliance.

As the authorize Natomas Unified School District official, I hereby certify that the requirements of Government Code Section 95995 have been complied with by the above signed applicant.

SIGNATURE: *Michael Morman* DATE: *11/2/01*  
 TITLE: Michael Morman  
Facilities Planning Director

Stantec



Stantec Consulting Inc.  
 2590 Venture Oaks Way  
 Sacramento, CA 95833-3288  
 Tel. 916.925.5550  
 Fax. 916.921.9274  
 www.stantec.com

RIVERWALK  
 UNIT NO. 2  
 LOT 98  
 PLAN 2655A

RIVERWALK  
 CITY OF SACRAMENTO, CA.  
 CLIENT: MYERS HOMES  
 JOB NO.: 843-00072

DATE: 3-12-02 Rev

A.P.N.:

ADDRESS: 3259 SPINNING ROD WAY

LOT AREA: 6,600 SF  
 LOT COVERAGE: 34%

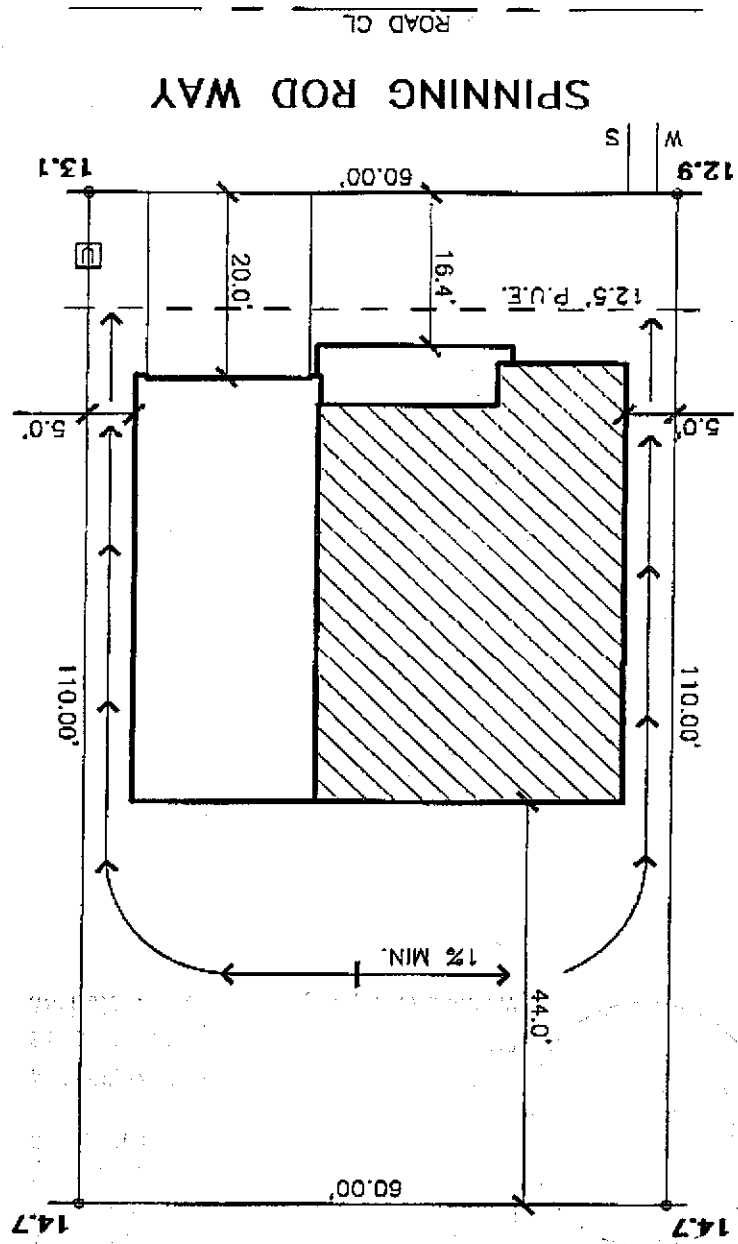

\* SWALE  
 ← STREET LIGHT

① TRANSFORMER  
 SS SEWER SERVICE  
 WS WATER SERVICE  
 ◆ FIRE HYDRANT

□ UTILITY SERVICE  
 ▣ DRAIN INLET

FROM : 916 264 8370 TO : 2002.03-22 10:45 #422 P.08/22