

**RESOLUTION NO. 2001-028**

ADOPTED BY THE SACRAMENTO CITY COUNCIL

ON DATE OF JAN 9 2001

**A RESOLUTION OF THE CITY OF SACRAMENTO CITY COUNCIL ADOPTING  
THE TRANSITION PLAN FOR CURB RAMPS AND APPROVING  
AMENDMENTS TO THE STANDARD SPECIFICATIONS FOR PUBLIC WORKS  
CONSTRUCTION**

**THE CITY COUNCIL OF THE CITY OF SACRAMENTO DOES RESOLVE AS FOLLOWS:**

1. The Transition Plan for Curb Ramps is hereby adopted.
2. The City of Sacramento Standard Specifications for Public Works Construction, dated June 1989, shall be amended by replacing Drawing Nos. CE 2, CE 3A, CE 3B, and CE 4 with the new Standard Drawings contained in Exhibit B.

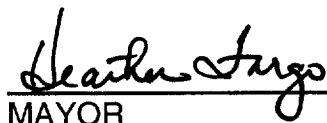
  
MAYOR

ATTEST:

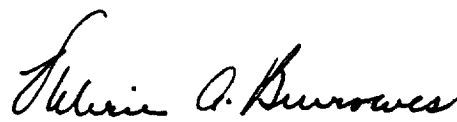
  
CITY CLERK

---

FOR CITY CLERK USE ONLY

RESOLUTION NO.: 2001-028

DATE ADOPTED: JAN 9 2001

**1) Sidewalk Transitions**

- Located above ramp or landing
- 48" minimum width
- 2% (1:50) maximum cross slope at ramp or landing
- 8.33% (1:12) maximum slope

**2) Landings**

- Located above ramp
- 48" minimum dimension in all directions
- 60" minimum length in direction of travel
- 2% (1:50) maximum cross slope or slope in all directions, including diagonal

**3) Ramps**

- Located above pan or below landing
- 48" minimum width
- 2% (1:50) maximum cross slope
- 8.33% (1:12) maximum slope
- If slope is less than 6.67% (1:15) then the ramp shall have truncated domes
- Transition to gutter shall be flush and free of abrupt changes

**4) Pans**

- Located below ramp
- 60" minimum at back of pan
- 48" minimum from back of pan to flow line
- 1% (1:100) minimum slope from back of pan to flow line
- 2% (1:50) maximum cross slope or slope in all directions, including diagonal
- On corners, pan boundaries are to be radial
- Transition to gutter shall be flush and free of abrupt changes

- Dual curb ramps are required unless otherwise approved by the Engineer.
- All elements, except gutters and retaining curbs, must be constructed planar in nature with weakened plane joints scored between each element.
- When feasible, opposing curb ramps shall align.
- These Definitions and Standards, General Details, and Standard Drawings shall apply to all curb and gutter types.
- There are variations and adjustments that may be required upon the approval of the Engineer.
- There are no variances to the maximum allowable slopes and cross slopes.

**5) Gutters**

- Adjacent to ramp or pan
- 5% (1:20) maximum slope
- Transition to ramp or pan shall be flush and free of abrupt changes

**6) Flares**

- Located adjacent to ramp
- Required between ramps where there is no planter area
- Required on the exterior of ramps where there is an adjacent concrete sidewalk, regardless of obstacles
- Generally triangular in nature
- 10% (1:10) maximum slope

**7) Retaining Curbs**

- Required adjacent to sidewalk transitions, landings, ramps and pans where the existing landscape (planter area) is 4" or higher at any point above the newly constructed curb ramp element
- Required for existing planter areas between ramps
- Retaining curbs are to have a 6" width and a vertical face
- Retaining curb foundations are to extend 8" below the adjacent ramp element surface
- Outside corners of retaining curbs must have a 6" radius

**8) 12" Grooving Details**

- Required adjacent to (on flat areas above) ramp and flare
- Required to be perpendicular to the path of travel

REV. NO.	DATE	DESCR.
<b>CITY OF SACRAMENTO</b> ENGINEERING DIVISION		
<b>CURB RAMP ELEMENTS, DEFINITIONS AND STANDARDS</b>		
APPROVED BY: <i>Ron Doherty</i>	SCALE: NONE	
DATE: 01/09/01	DWG NO: CE 2	

RESOLUTION NO. 2001-028

JAN 9 2001

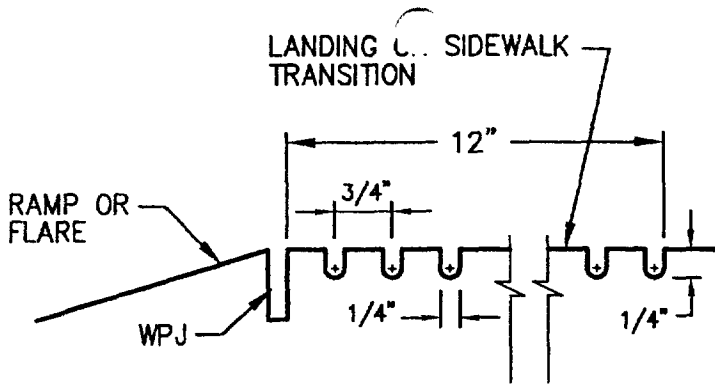

**12" GROOVING DETAIL**

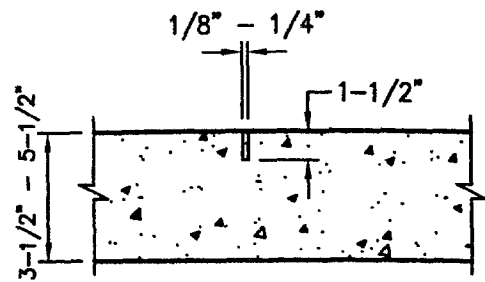

**WEAKENED PLANE JOINT (WPJ)**

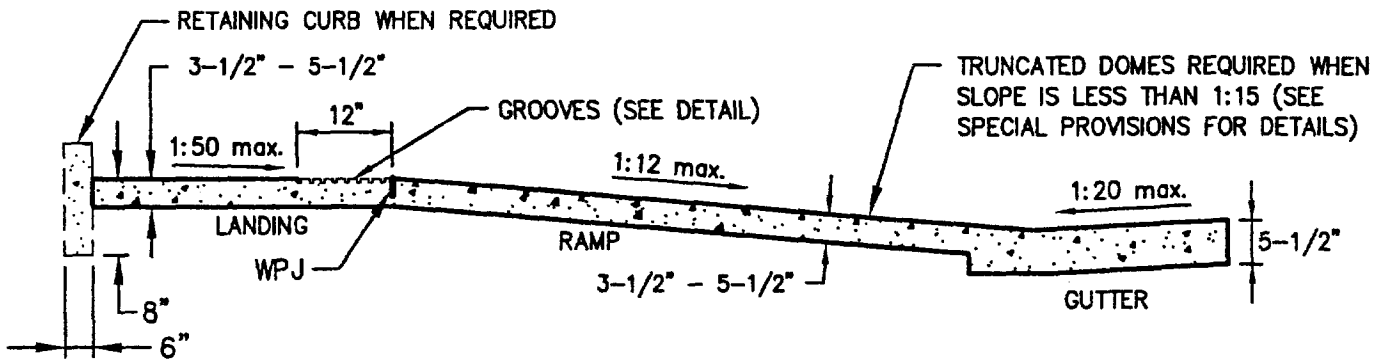

**TYPICAL CROSS SECTION  
FOR CENTER LINE OF FLARE, COMBO,  
OR PLANTER STRIP CURB RAMP**

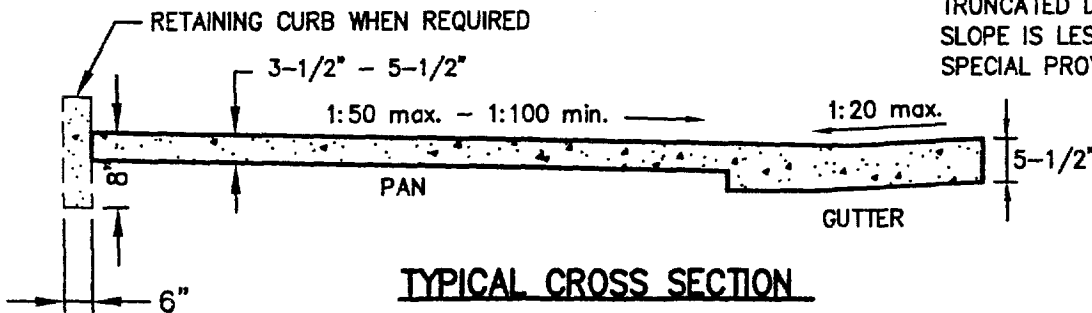

**TYPICAL CROSS SECTION  
FOR CENTER LINE OF  
PAN CURB RAMP**

**NOTE:** ON RAMPS ADJACENT TO PANS TRUNCATED DOMES REQUIRED WHEN SLOPE IS LESS THAN 1:15 (SEE SPECIAL PROVISIONS FOR DETAILS)

**NOTES:**

- A. SURFACE OF RAMPS AND PANS SHALL HAVE A TRANSVERSE BROOM SURFACE TEXTURE ROUGHER THAN ADJACENT SIDEWALK.
- B. LAMP BLACK SHALL BE ADDED TO NEW CONCRETE AS NECESSARY TO MATCH EXISTING COLOR.

REV. NO.	DATE	DESCR.
<b>CITY OF SACRAMENTO ENGINEERING DIVISION</b>		
<b>CURB RAMP GENERAL DETAILS</b>		
APPROVED BY: <i>Ken Drehm</i>		SCALE: NONE
DATE: 01/09/01	DWG NO.: CE 3	

**RESOLUTION NO. 2001-028**

**JAN 9 2001**

**NOTES:**

- A. ALL SLOPES SHOWN ARE MAXIMUMS.
- B. ALL DIMENSIONS SHOWN ARE MINIMUMS.
- C. ALL PANS MUST BE LOCATED INSIDE CROSSWALKS OR IN FRONT OF STOP BARS.
- D. ALL JOINTS BETWEEN ELEMENTS ARE RADIAL.
- E. SINGLE RAMPS CAN BE CONSTRUCTED ON A TANGENT.
- \* CONSTRUCTED IF REQUIRED BY EXISTING CONDITIONS.
- \*\* MINIMUM SLOPE OF 1% (1:100) FROM BACK OF PAN TO FLOW LINE.
- DESIGNATES IN PLAN VIEWS THAT ELEMENT MAY BE CONSTRUCTED.

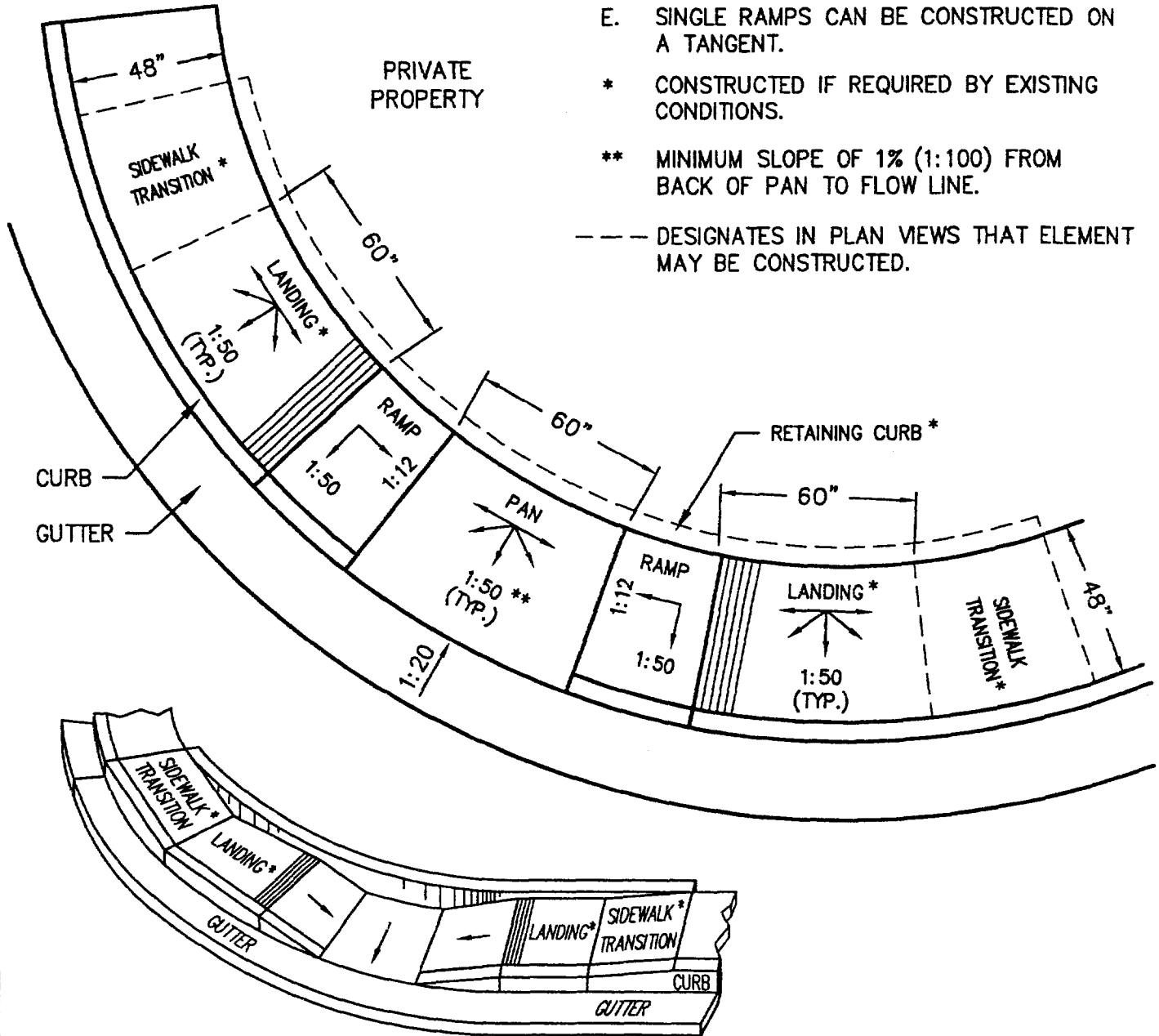

REV. NO.	DATE	DESCR.
<b>CITY OF SACRAMENTO</b> ENGINEERING DIVISION		
<b>SINGLE PAN CURB RAMP</b>		
APPROVED BY: <i>Ken Dehm</i>		SCALE: NONE
DATE: 01/08/01	DWG NO.: CE 4.0	

RESOLUTION NO. 2001-028

JAN 9 2001

**NOTES:**

- A. ALL SLOPES SHOWN ARE MAXIMUMS.
- B. ALL DIMENSIONS SHOWN ARE MINIMUMS.
- C. ALL PANS MUST BE LOCATED INSIDE CROSSWALKS OR IN FRONT OF STOP BARS.
- D. ALL JOINTS BETWEEN ELEMENTS ARE RADIAL.

\* CONSTRUCTED IF REQUIRED BY EXISTING CONDITIONS.

\*\* MINIMUM SLOPE OF 1% (1:100) FROM BACK OF PAN TO FLOW LINE.

① 4" MINIMUM CURB HEIGHT, UNLESS OTHERWISE APPROVED BY THE ENGINEER.

--- DESIGNATES IN PLAN VIEWS THAT ELEMENT MAY BE CONSTRUCTED.

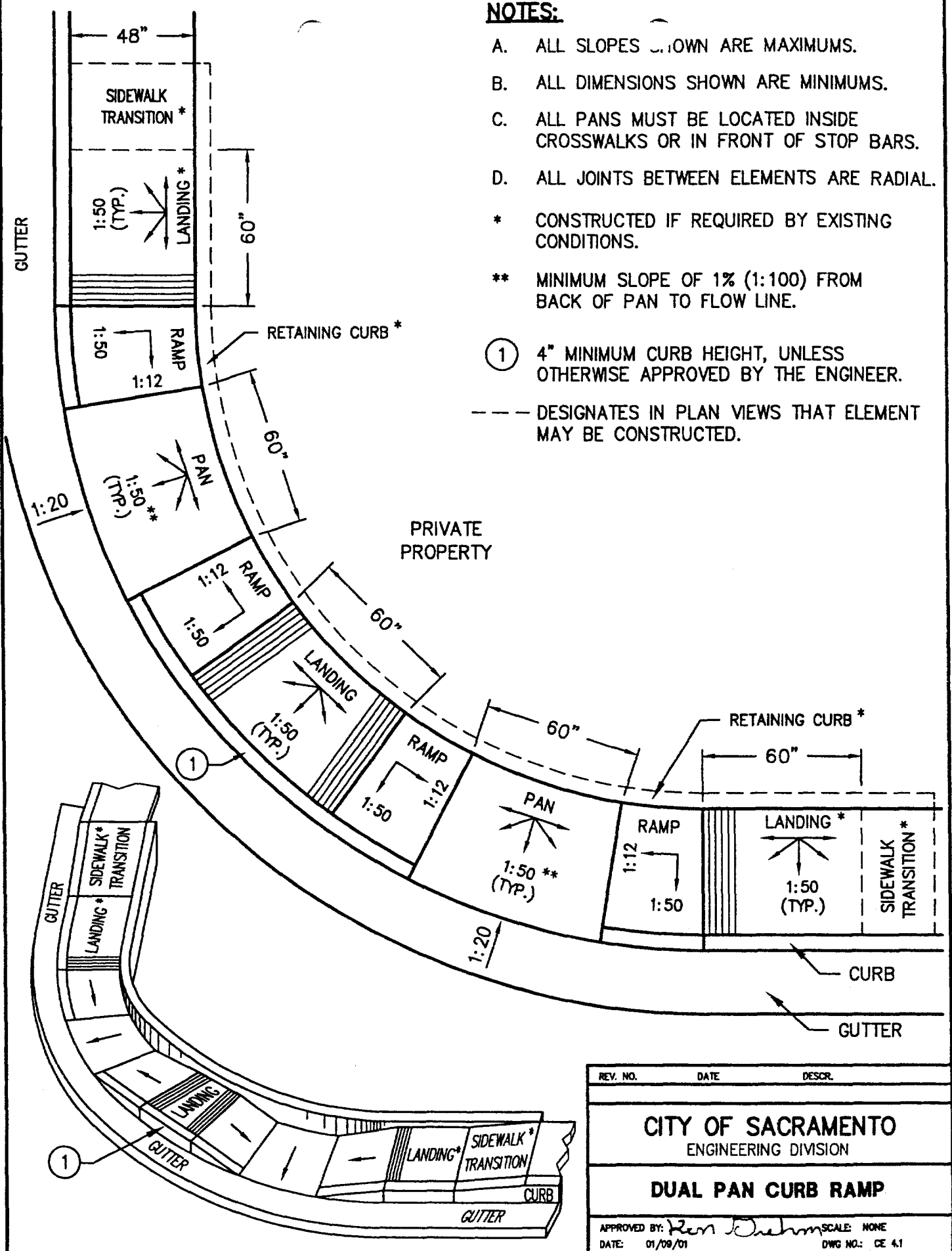

REV. NO.	DATE	DESCR.
<b>CITY OF SACRAMENTO</b> ENGINEERING DIVISION		
<b>DUAL PAN CURB RAMP</b>		
APPROVED BY: <i>Ken Dehman</i>		SCALE: NONE
DATE: 01/09/01	DWG NO.: CE 4.1	

RESOLUTION NO. 2001-028

JAN 9 2001

**NOTES:**

- A. ALL SLOPES SHOWN ARE MAXIMUMS.
- B. ALL DIMENSIONS SHOWN ARE MINIMUMS.
- C. ALL RAMPS MUST BE LOCATED INSIDE CROSSWALKS OR IN FRONT OF STOP BARS.
- D. ALL JOINTS BETWEEN ELEMENTS, EXCEPT BETWEEN RAMP AND FLARE, ARE RADIAL. RAMP WIDTH REMAINS CONSTANT.
- E. SINGLE RAMPS CAN BE CONSTRUCTED ON A TANGENT.
- \* CONSTRUCTED IF REQUIRED BY EXISTING CONDITIONS.

① IF LANDING CONSTRUCTED, 60" MIN. LANDING DIMENSION AND 60" MIN. WIDTH OF RAMP REQUIRED.

--- DESIGNATES IN PLAN VIEWS THAT ELEMENT MAY BE CONSTRUCTED.

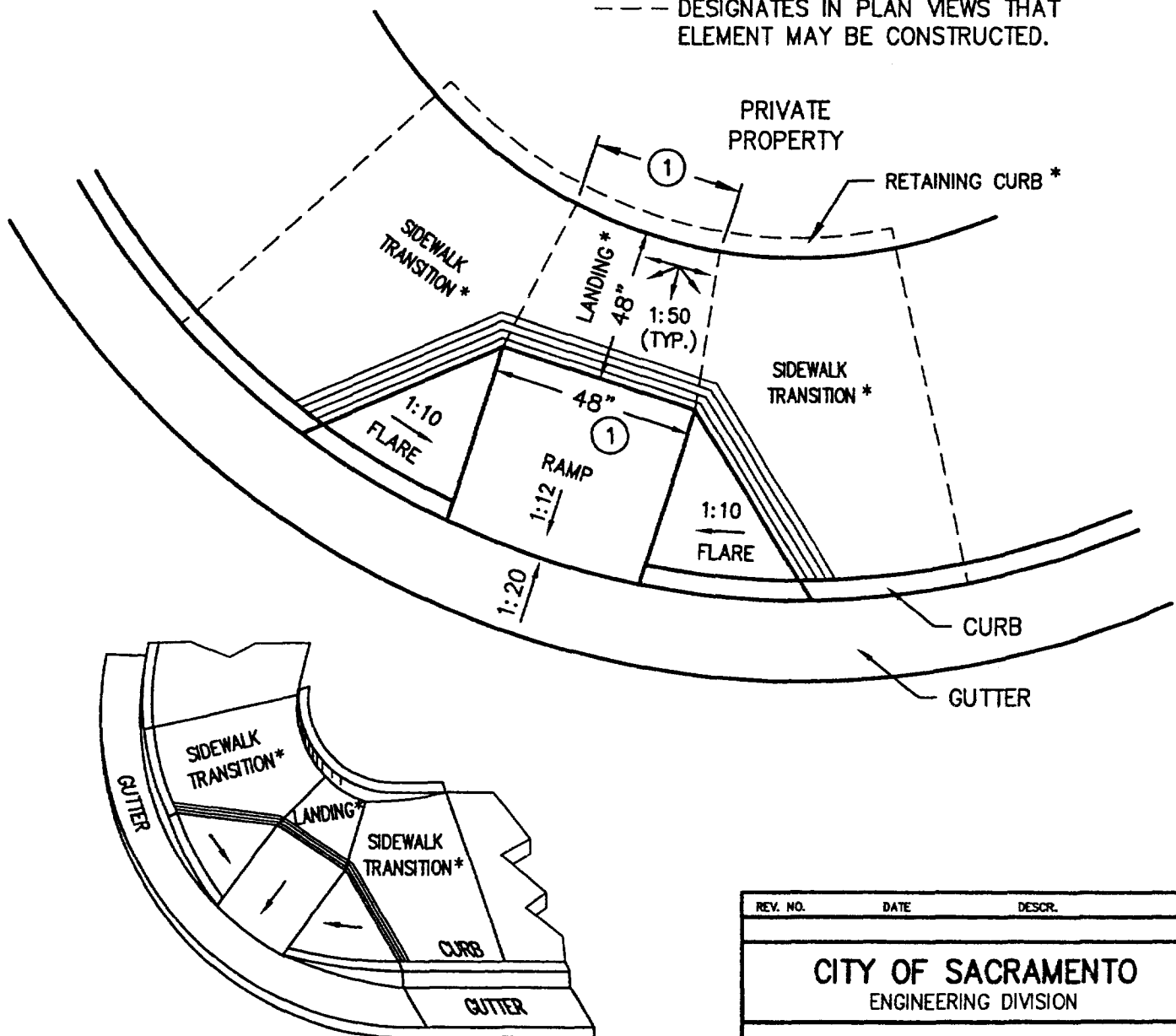

REV. NO.	DATE	DESCR.
<b>CITY OF SACRAMENTO</b> ENGINEERING DIVISION		
<b>SINGLE FLARE CURB RAMP</b>		
APPROVED BY: <i>Ken Dehm</i>		SCALE: NONE
DATE: 01/09/01	DWG NO.: CE 4.2	

RESOLUTION NO. 2001-028  
JAN 9 2001

**NOTES:**

- A. ALL SLOPES SHOWN ARE MAXIMUMS.
- B. ALL DIMENSIONS SHOWN ARE MINIMUMS.
- C. ALL RAMPS MUST BE LOCATED INSIDE CROSSWALKS OR IN FRONT OF STOP BARS.

\* CONSTRUCTED IF REQUIRED BY EXISTING CONDITIONS.

--- DESIGNATES IN PLAN VIEWS THAT ELEMENT MAY BE CONSTRUCTED.

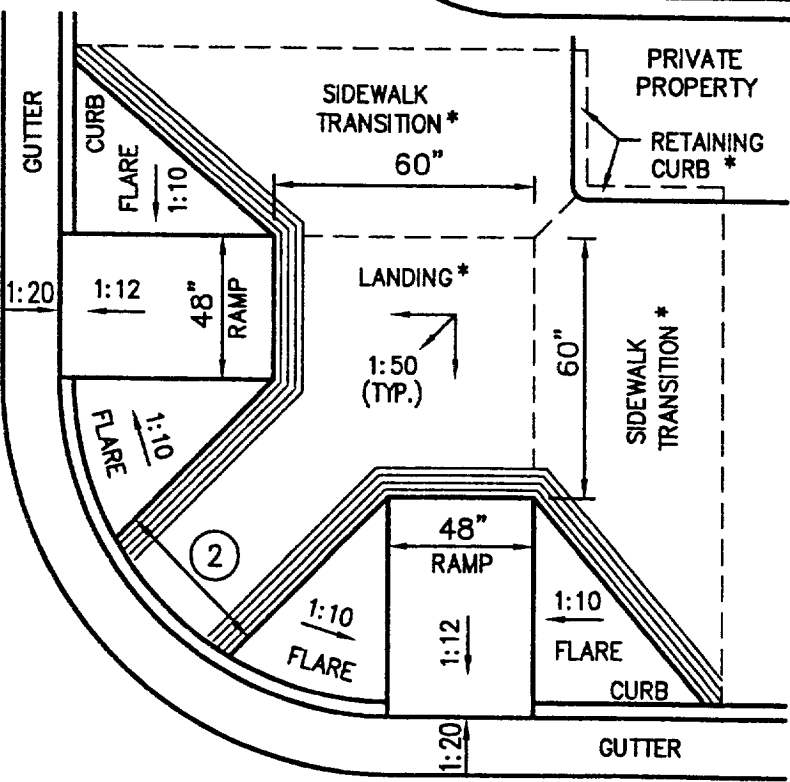
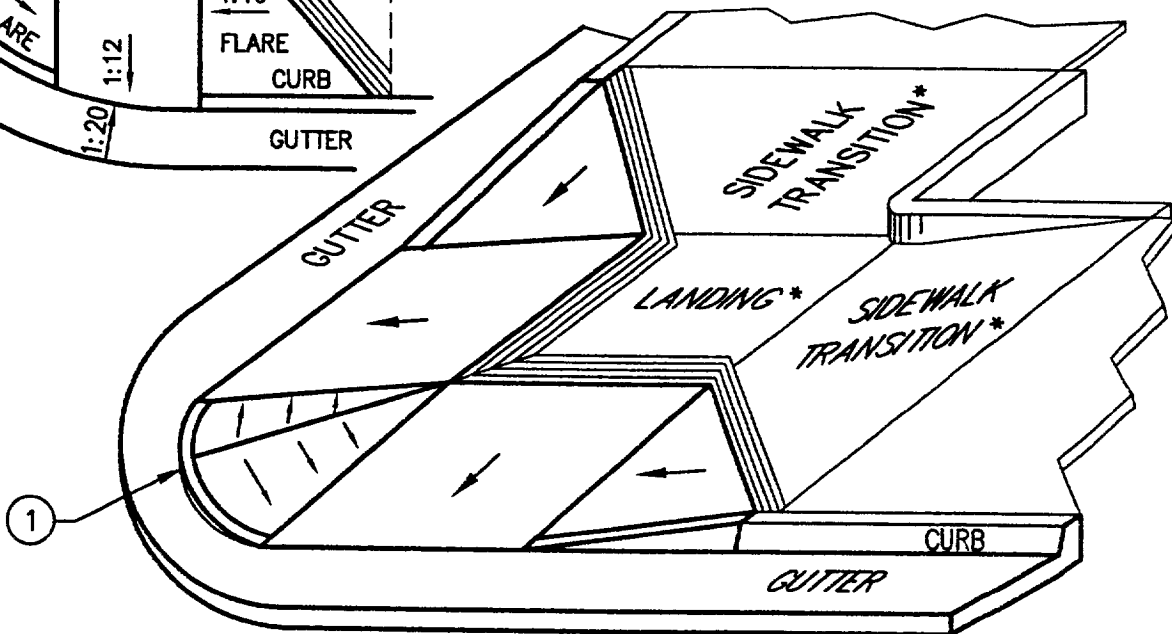
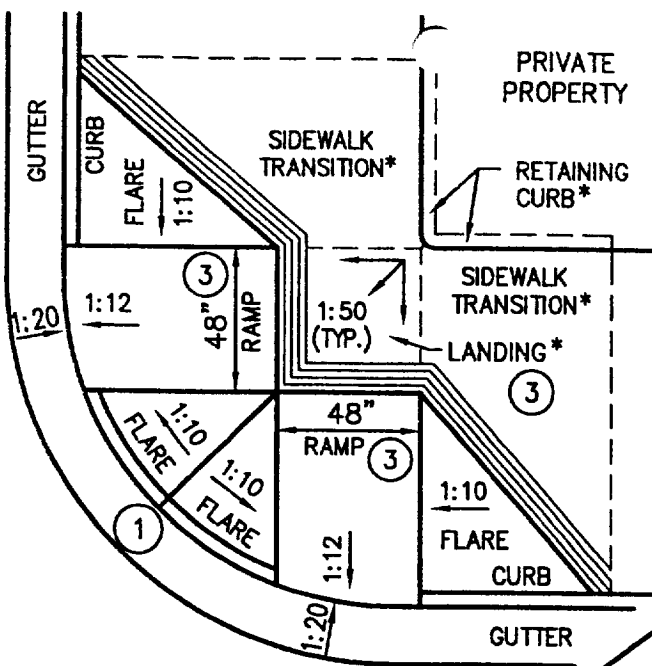

**NOTES:**

- ① 4" MINIMUM CURB HEIGHT, UNLESS OTHERWISE APPROVED BY THE ENGINEER.
- ② NO MINIMUM DIMENSION. GROOVE PATTERNS OR FLARES CAN INTERSECT.
- ③ IF LANDING CONSTRUCTED, 60" MIN. LANDING DIMENSIONS AND 60" MIN. WIDTH OF RAMP REQUIRED.

REV. NO.	DATE	DESCR.
<b>CITY OF SACRAMENTO</b> ENGINEERING DIVISION		
<b>DUAL FLARE CURB RAMP</b>		
APPROVED BY: <i>Ben Dohm</i>		SCALE: NONE
DATE: 01/09/01	DWG NO.: CE 4.3	

RESOLUTION NO. 2001-028  
JAN 9 2001

**NOTES:**

- A. ALL SLOPES SHOWN ARE MAXIMUMS.
- B. ALL DIMENSIONS SHOWN ARE MINIMUMS.
- C. ALL RAMPS MUST BE LOCATED INSIDE CROSSWALKS OR IN FRONT OF STOP BARS.
- D. ALL JOINTS BETWEEN ELEMENTS, EXCEPT BETWEEN RAMP AND FLARE, ARE RADIAL. RAMP WIDTH REMAINS CONSTANT.
- E. SINGLE RAMPS CAN BE CONSTRUCTED ON A TANGENT.
- \* CONSTRUCTED IF REQUIRED BY EXISTING CONDITIONS.

--- DESIGNATES IN PLAN VIEWS THAT ELEMENT MAY BE CONSTRUCTED.

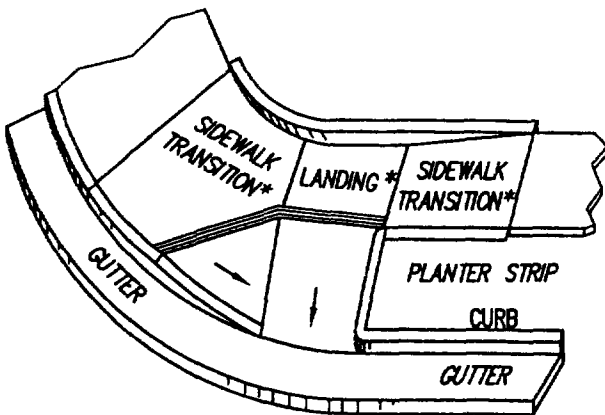
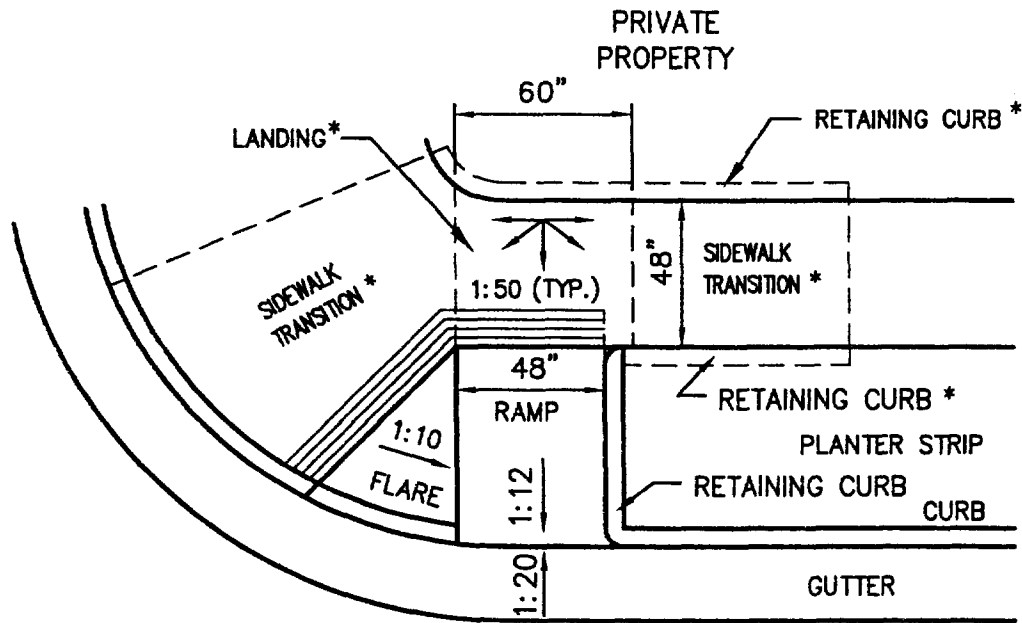

REV. NO.	DATE	DESCR.
<b>CITY OF SACRAMENTO</b> ENGINEERING DIVISION		
<b>SINGLE COMBINATION CURB RAMP</b>		
APPROVED BY: <i>Ben Duhm</i>		SCALE: NONE
DATE: 01/09/01	DWG NO.: CE 4.4	

RESOLUTION NO. 2001-028

JAN 9 2001



**NOTES:**

- A. ALL SLOPES SHOWN ARE MAXIMUMS.
- B. ALL DIMENSIONS SHOWN ARE MINIMUMS.
- C. ALL RAMPS MUST BE LOCATED INSIDE CROSSWALKS OR IN FRONT OF STOP BARS.
- \* CONSTRUCTED IF REQUIRED BY EXISTING CONDITIONS.

--- DESIGNATES IN PLAN VIEWS THAT ELEMENT MAY BE CONSTRUCTED.

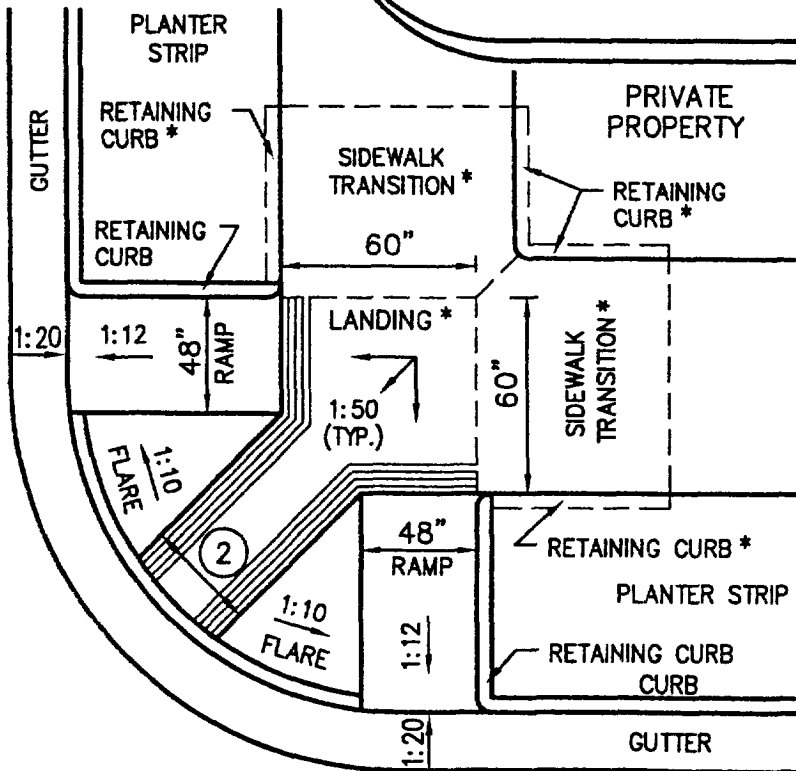
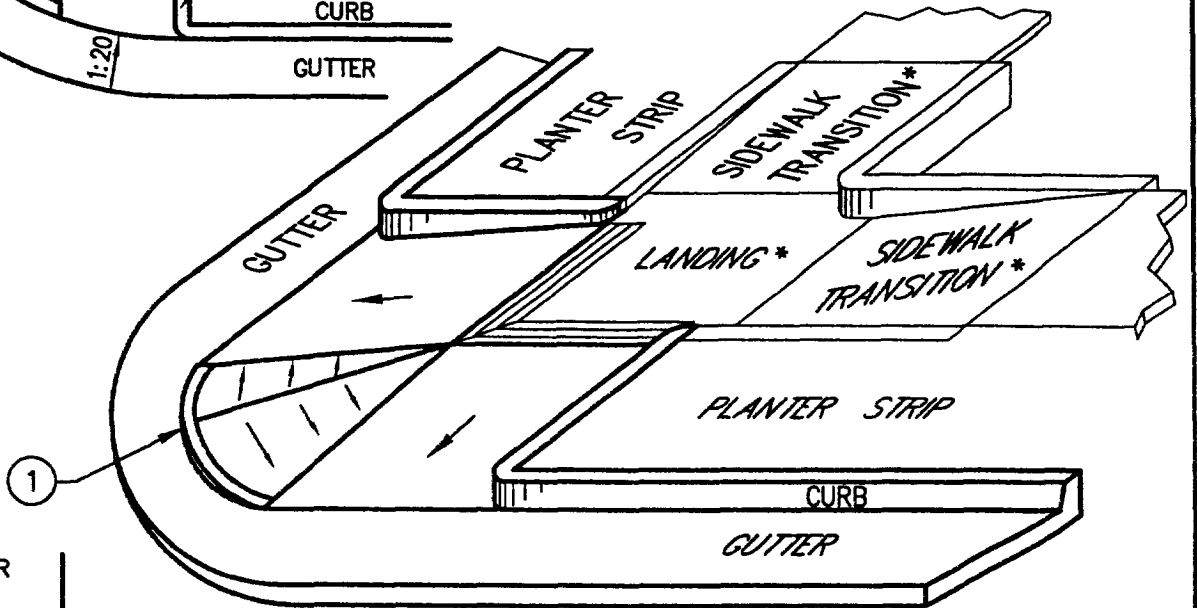
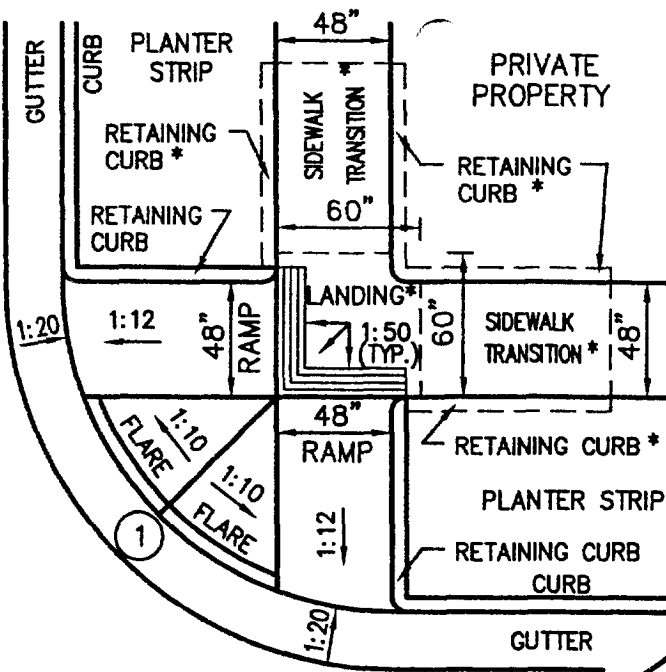

**NOTES:**

- ① 4" MINIMUM CURB HEIGHT, UNLESS OTHERWISE APPROVED BY THE ENGINEER.
- ② NO MINIMUM DIMENSION. GROOVE PATTERNS OR FLARES CAN INTERSECT.

REV. NO.	DATE	DESCR.
<b>CITY OF SACRAMENTO</b> ENGINEERING DIVISION		
<b>DUAL COMBINATION CURB RAMP</b>		
APPROVED BY: <i>Ben Duhon</i>		SCALE: NONE
DATE: 01/08/01	DWG NO.: CE 4.5	

RESOLUTION NO. 2001-028

JAN 9 2001

**NOTES:**

- A. ALL SLOPES SHOWN ARE MAXIMUMS.
- B. ALL DIMENSIONS SHOWN ARE MINIMUMS.
- C. ALL RAMPS MUST BE LOCATED INSIDE CROSSWALKS OR IN FRONT OF STOP BARS.
- D. LAMP BLACK SHALL BE ADDED TO NEW CONCRETE TO MATCH EXISTING COLOR.
- \* CONSTRUCTED IF REQUIRED BY EXISTING CONDITIONS.
- \*\* CONTINUE TO MATCH SIDEWALK WIDTH AND SCORE PATTERN (MIN. 48" WIDE).
- DESIGNATES IN PLAN VIEWS THAT ELEMENT MAY BE CONSTRUCTED.

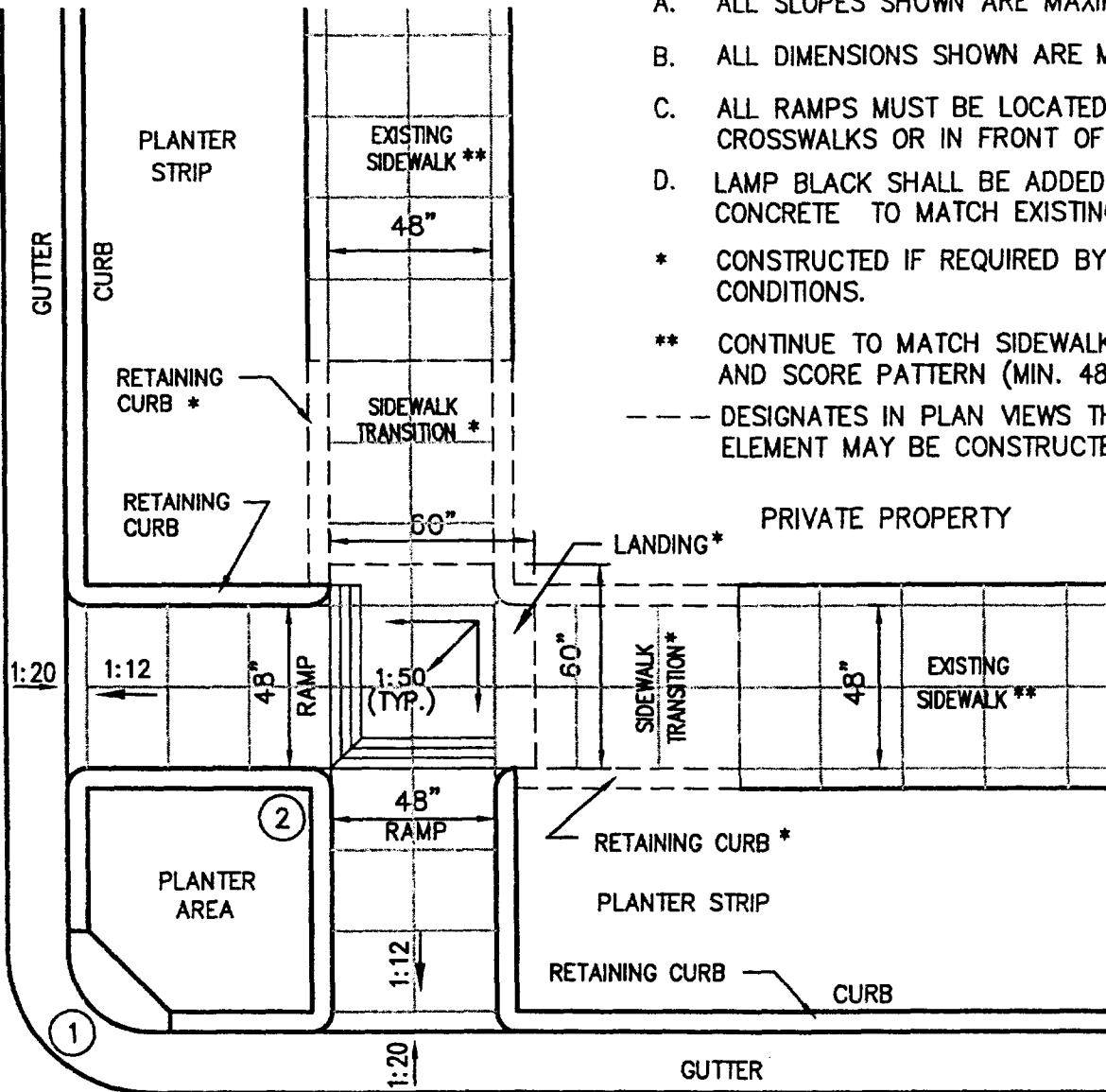

**NOTES:**

- ① STANDARD CURB HEIGHT TO MATCH EXISTING.
- ② TOP OF RETAINING CURB TO MATCH ADJACENT RETAINING CURB ELEVATIONS. CAN BE FLUSH WITH LANDING.

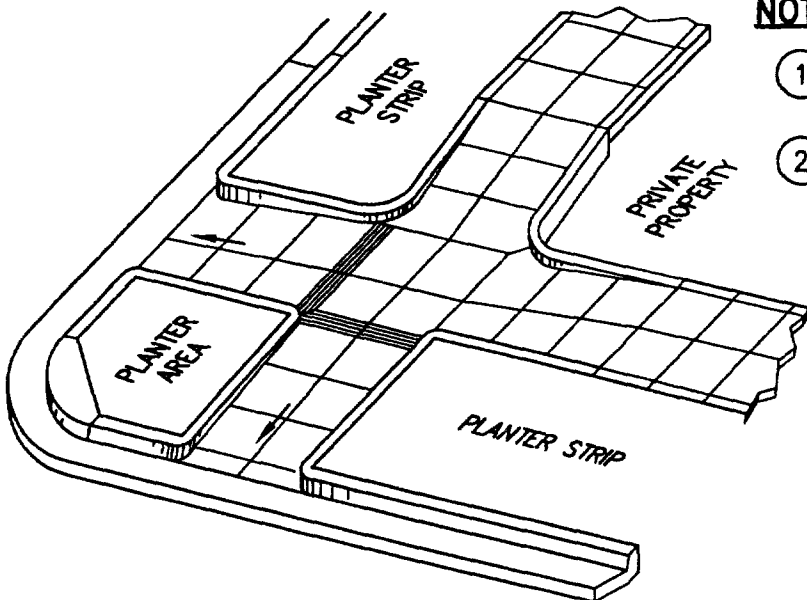

REV. NO.	DATE	DESCR.
<b>CITY OF SACRAMENTO</b> ENGINEERING DIVISION		
<b>PLANTER STRIP CURB RAMP</b>		
APPROVED BY: <i>Ken Dehm</i>		SCALE: NONE
DATE: 01/09/01	DWG NO.: CE 4.8	

RESOLUTION NO. 2001-028

JAN 9 2001

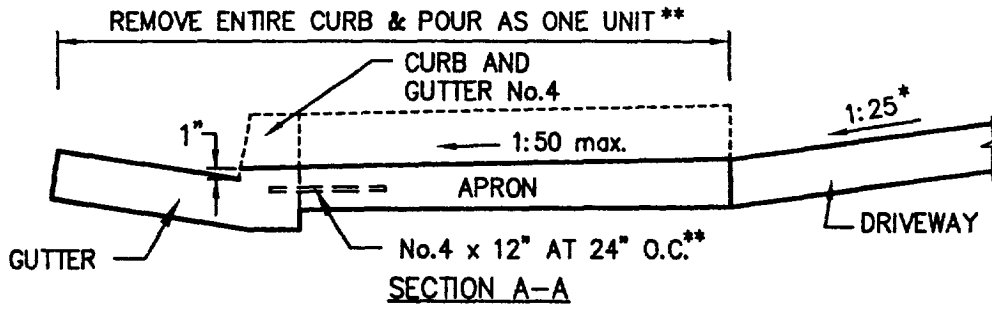
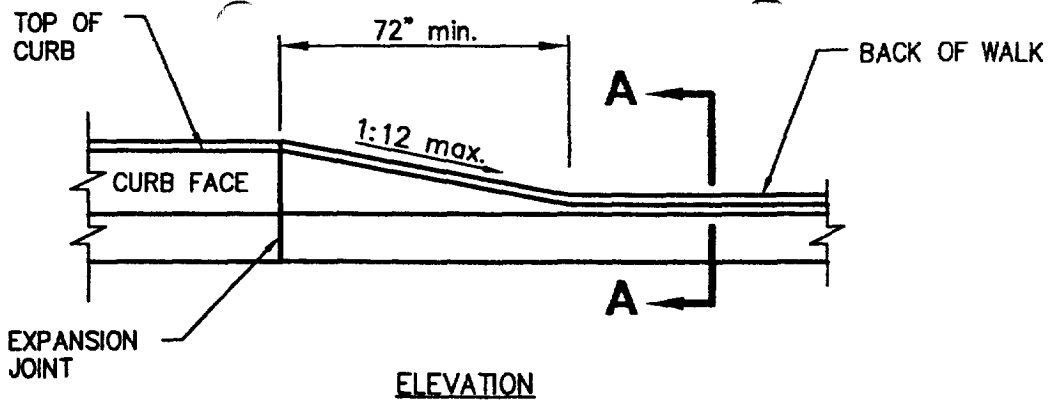

**NOTES:**

- A. DRIVEWAY WIDTH AS PER SEC. 38 CITY CODE.
  - B. WEAKENED PLANE JOINTS (WPJ) REQUIRED ON CENTERLINE FOR DRIVEWAYS 10' TO 20' WIDE. DRIVEWAYS 22' TO 35' WIDE SHALL HAVE TWO WPJ EVENLY SPACED AT 1/3 AND 2/3 POINTS.
  - C. ALL CONSTRUCTION AND MATERIALS IN CONFORMANCE WITH SEC. 24 OF STANDARD SPECIFICATIONS.
  - D. THICKNESS OF APRONS SHALL BE 4" ON RESIDENTIAL DRIVEWAYS AND 6" ON COMMERCIAL DRIVEWAYS. ON COMMERCIAL DRIVEWAYS SIDEWALK SHALL BE REMOVED AND REPLACED WITH 6" OF CONCRETE.
  - E. APRON WILL BE DEPRESSED ON CURB AND GUTTER No.13 WHEN RECONSTRUCTING EXISTING COMMERCIAL DRIVEWAYS.
- DESIGNATES THAT ELEMENT MAY BE CONSTRUCTED.
- \* ON RECONSTRUCTION THE SLOPE CAN BE 1:10.
- \*\* IF CURB & GUTTER ARE POURED SEPARATE OF APRON THEN DOWELS ARE REQUIRED AT BACK OF CURB. 3" IN CURB AND 9" IN CENTER OF APRON.

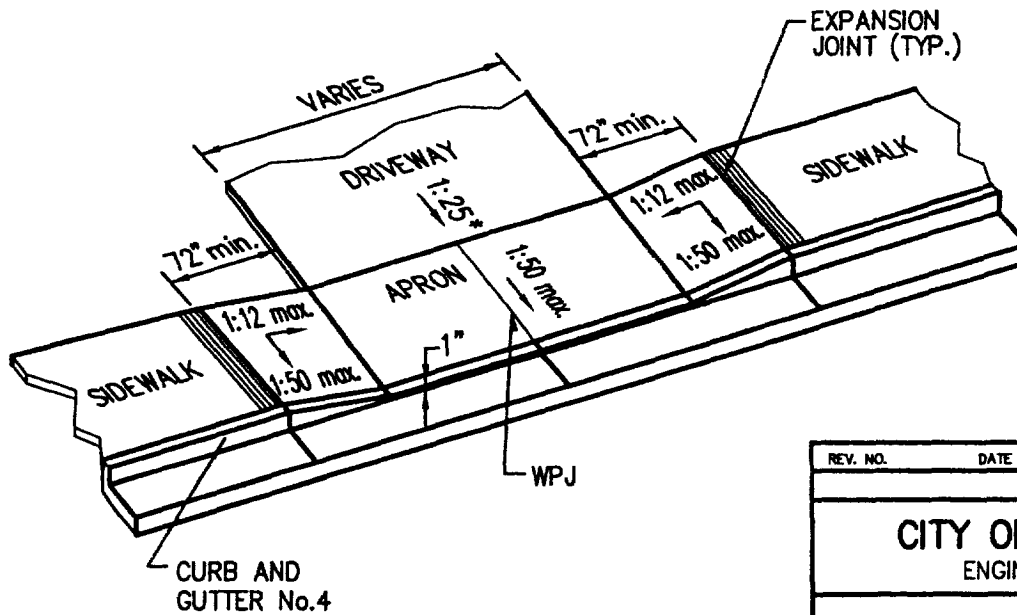

REV. NO.	DATE	DESCR.
CITY OF SACRAMENTO ENGINEERING DIVISION		
<b>SIDEWALK DRIVEWAY DETAIL</b>		
APPROVED BY: <i>Ben Dehm</i>		SCALE: NONE
DATE: 01/09/01	DWG NO.: CE 4.7	

RESOLUTION NO. 2001-028

JAN 9 2001

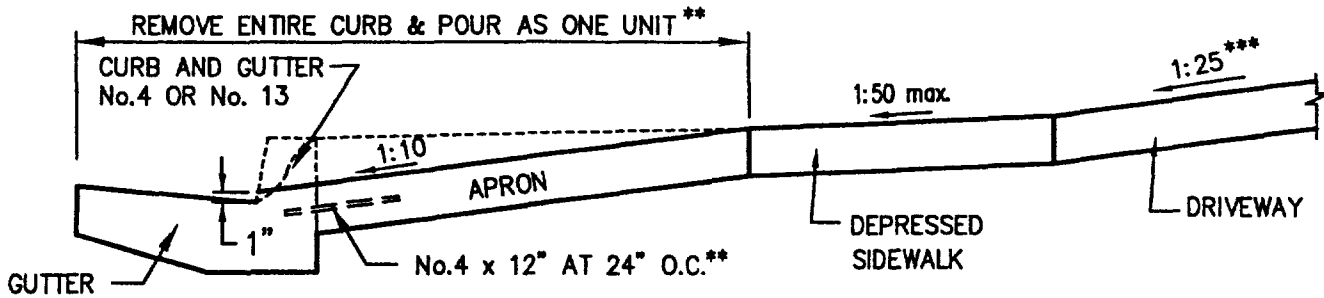
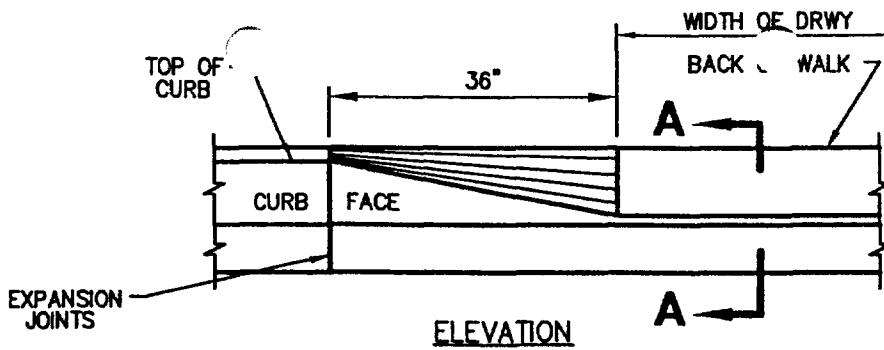

SECTION A-A WITH VERTICAL CURB

**NOTES:**

- A. DRIVEWAY WIDTH AS PER SEC. 38 CITY CODE.
  - B. WEAKENED PLANE JOINTS (WPJ) REQUIRED ON CENTERLINE FOR DRIVEWAYS 10' TO 20' WIDE. DRIVEWAYS 22' TO 35' WIDE SHALL HAVE TWO WPJ EVENLY SPACED AT 1/3 AND 2/3 POINTS.
  - C. ALL CONSTRUCTION AND MATERIALS IN CONFORMANCE WITH SEC. 24 OF STANDARD SPECIFICATIONS.
  - D. THICKNESS OF APRONS SHALL BE 4" ON RESIDENTIAL DRIVEWAYS AND 6" ON COMMERCIAL DRIVEWAYS. ON COMMERCIAL DRIVEWAYS SIDEWALK SHALL BE REMOVED AND REPLACED WITH 6" OF CONCRETE.
- DESIGNATES THAT ELEMENT MAY BE CONSTRUCTED.  
 \* CONSTRUCTED IF REQUIRED BY EXISTING CONDITIONS.  
 \*\* IF CURB AND GUTTER ARE POURED SEPARATE OF APRON THEN DOWELS ARE REQUIRED AT BACK OF CURB. 3" IN CURB AND 9" IN CENTER OF APRON.  
 \*\*\* ON RECONSTRUCTION THE SLOPE CAN BE 1:10.

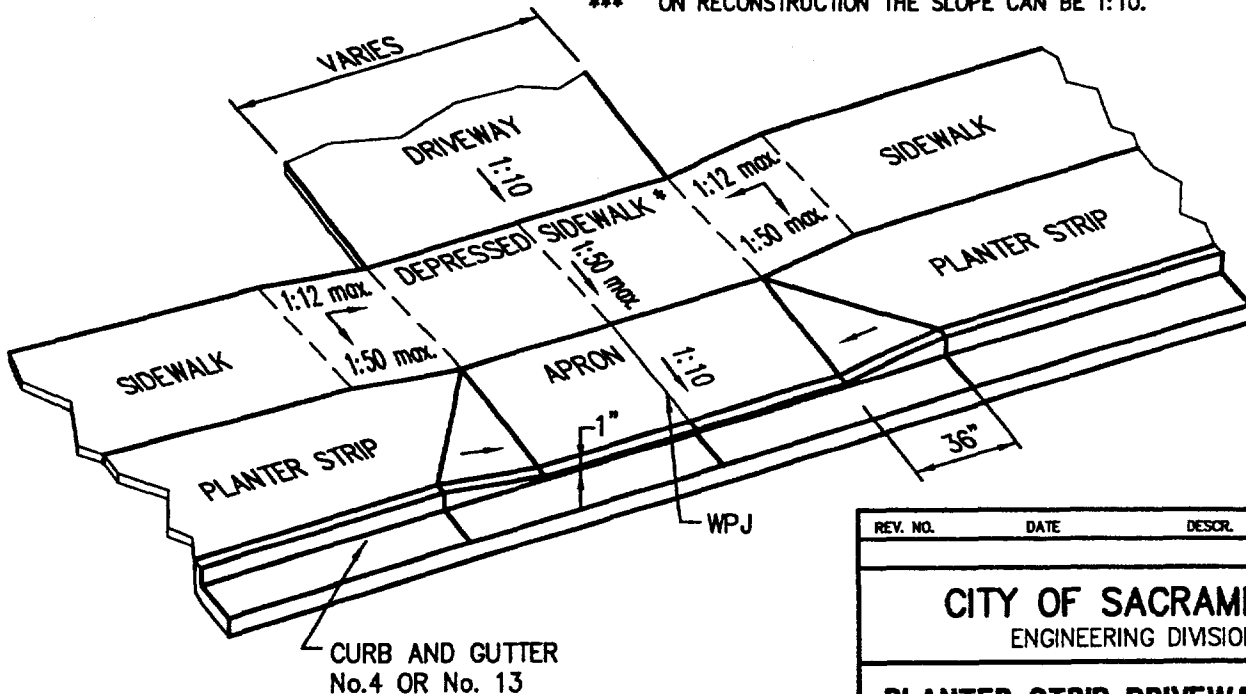

REV. NO.	DATE	DESCR.
<b>CITY OF SACRAMENTO</b> ENGINEERING DIVISION		
<b>PLANTER STRIP DRIVEWAY DETAIL</b>		
APPROVED BY: <i>Ken Dehm</i>		SCALE: NONE
DATE: 01/09/01	DWG NO.: CE 4.8	

RESOLUTION NO. 2001-028

JAN 9 2001